

## ORDINANCE 01-01-2019

### AN ORDINANCE ADOPTING A STORM DRAINAGE MASTER PLAN, PROVIDING FOR CODIFICATION, CORRECTION OF SCRIVENER'S ERRORS, SEVERABILITY, AND AN EFFECTIVE DATE.

WHEREAS, Santaquin City (the "City") is a political subdivision of the State of Utah, authorized and organized under applicable provisions of Utah law; and

WHEREAS, Santaquin has experienced tremendous growth in the past and anticipates more growth in the future; and

WHEREAS, a storm drainage master plan is necessary to be used as a reference for planning, budgeting and development and to assist the city by providing a plan to correct existing storm water deficiencies and identify infrastructure needs for future development; and

WHEREAS, the City recently commissioned Horrocks Engineers to prepare a Storm Drainage Master Plan to establish long term plans for the handling of storm water infrastructure in the City.

**NOW, THEREFORE, BE IT ORDAINED BY THE CITY COUNCIL OF Santaquin CITY, STATE OF UTAH, AS FOLLOWS:**

#### **SECTION I. Adoption of Master Transportation Plan**

The attached Storm Drainage Master Plan, prepared by Horrocks Engineers, is hereby adopted as the official Storm Drainage Master Plan of Santaquin City.

#### **SECTION II. Codification, Inclusion in the Code, and Scrivener's Errors**

It is the intent of the City Council that the provisions of this ordinance be made part of the City Code as adopted, that sections of this ordinance may be re-numbered or re-lettered, that the word ordinance may be changed to section, chapter, or other such appropriate phrase in order to accomplish such intent regardless of whether such inclusion in a code is accomplished, sections of the ordinance may be re-numbered or re-lettered. Typographical errors which do not affect the intent of this ordinance may be authorized by the City without need of public hearing by its filling a corrected or re-codified copy of the same with the City Recorder.

#### **SECTION III. Severability**

If any section, phrase, sentence, or portion of this ordinance is for any reason held invalid or unconstitutional by any court of competent jurisdiction, such portion shall be deemed a separate, distinct, and independent provision, and such holding shall not affect the validity of the remaining portions thereof.

**SECTION IV. Effective Date**

The City Recorder shall deposit a copy of this ordinance in the official records of the City on January 16, 2019, and before 5:00 p.m. on that day, shall place a copy of this ordinance in three places within the City. This ordinance shall become effective at 5:00 p.m. on January 16, 2019.

**PASSED AND APPROVED** this 15<sup>th</sup> day of January, 2019.

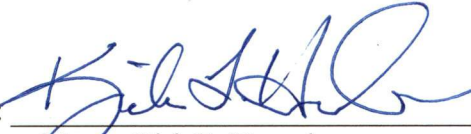
By:   
\_\_\_\_\_  
Mayor Kirk F. Hunsaker

**ATTEST:**

By:   
\_\_\_\_\_  
Susan Farnsworth, City Recorder

**Voting:**

Council Member Keith Broadhead



Council Member Nick Miller



Council Member Betsy Montoya



Council Member Chelsea Rowley



Council Member Lynn Mecham



# 2018

## SANTAQUIN

STORM DRAIN MASTER PLAN



*Santaquin*

PREPARED BY:  
**HORROCKS**  
ENGINEERS

## CONTENTS

<b>Storm Drain Master Plan</b> .....	<b>1</b>
Introduction .....	1
Background .....	1
Topography .....	1
Purpose .....	1
<b>Approach to Drainage in Santaquin</b> .....	<b>2</b>
<b>Design Guidelines</b> .....	<b>2</b>
Hydrologic Methods.....	3
Design Storm .....	4
Precipitation Depth .....	5
Temporal Distribution.....	5
Minimum Pipe Size .....	6
Manhole/Cleanout Spacing.....	6
Retention and Detention Systems .....	6
Infiltration Gallery Requirements .....	6
Retention and Detention Basins .....	7
Street Drainage .....	9
Bench Area (Hillside Development) .....	10
Burned Conditions and Debris Flows – General .....	10
Burned Conditions and Debris Flows – Planning .....	10
Post Fire Hydrology .....	11
Recommended Burned Condition Resources .....	13
<b>MS4 and LID Implementation</b> .....	<b>14</b>
Status And Expectations For Enforcement Of MS4 Permits In Utah .....	14
Documents Required for stormwater management and MS4 implementation .....	15
Minimum Control Measures .....	16
Minimum Control Measure Recommendations .....	17
1 - Public Education and Outreach.....	17
2 - Public Participation and Involvement.....	18
3 - Illicit Discharge Detection and Elimination (IDDE).....	20

4 - Construction Site Storm Water Runoff Control .....	22
5 - Long-Term Storm Water Management in New Development and Redevelopment (Post Construction BMPs) .....	29
6 - Pollution Prevention and Good Housekeeping for Municipal Operations .....	35
<b>Maintenance Guidelines .....</b>	<b>37</b>
Inspection and cleaning Schedule.....	37
High Priority Areas .....	40
Post-Fire Watershed Mitigation.....	40
Maintenance Record keeping .....	40
<b>Drainage Policies.....</b>	<b>41</b>
General Requirements .....	41
Design Requirements.....	42
<b>Existing System .....</b>	<b>49</b>
<b>Hydrologic Model .....</b>	<b>56</b>
Modeling Parameters .....	56
Town Center.....	56
Town Center Rights-of-way .....	56
Block by Block Infiltration Gallery.....	60
Common Infiltration Pipeline.....	60
Two-Block Infiltration Gallery .....	60
Localized Storm Chambers.....	60
Hillside Areas.....	61
<b>Existing Deficiencies.....</b>	<b>64</b>
Public comments.....	64
City Staff.....	66
Hydrology model.....	66
Field investigation .....	66
proposed Projects To Address Deficiencies .....	67
Cost Estimate for Proposed projects for Existing Deficiencies .....	72
Methods of Financing Existing deficiency Projects .....	72
<b>Needs for Future Growth .....</b>	<b>75</b>
Spillway Conveyance Channel.....	75

Debris Basins .....	76
Retention Basins in Commercial and Industrial Areas .....	76
Regional Ponds.....	76
Park Strips .....	76
Retention in the Santaquin Canyon Spillway Channel.....	77
<b>Recommended future growth projects.....</b>	<b>79</b>
Future growth Project Descriptions.....	80
<b>Capital Facilities Plan .....</b>	<b>84</b>
Definitions.....	84
General/CFP Introduction .....	85
Level of Service (LOS).....	85
Demographics .....	85
Average Residents per Household .....	86
Current & Future Growth.....	86
Future Growth Trends.....	87
Existing Facilities .....	88
Existing Deficiencies .....	88
Future Growth Facilities.....	89
Capital Facilities Plan Projects Map .....	90
Schedule.....	92
<b>Impact Fee Facilities Plan .....</b>	<b>95</b>
Proportionate Share.....	95
ELIGIBLE IMPACT FEE PROJECTS.....	95
<b>Impact Fee Analysis .....</b>	<b>99</b>
Case-by-case Impact Fee Adjustments .....	99
Impact Fee Calculations .....	99
ERU Projections.....	99
Impact Fee Calculations .....	101
Regional Pond Impact Fee .....	102
Recommended impact fees .....	103
<b>Conclusion .....</b>	<b>105</b>
Planning .....	105

Planning .....	105
Future Development .....	105
<b>Appendices .....</b>	<b>106</b>
<b>Appendix A – Existing Conditions Watershed Maps.....</b>	<b>39</b>
<b>Appendix B – Existing Deficiencies Cost Estimates.....</b>	<b>40</b>
<b>Appendix C – Town Center Options.....</b>	<b>41</b>
<b>Appendix D – Buildout Conditions Watershed Map.....</b>	<b>42</b>
<b>Appendix E – Buildout Conditions Project Estimates .....</b>	<b>43</b>
<b>Appendix F – Storm Distributions.....</b>	<b>44</b>
<b>Appendix G – Precipitation Data .....</b>	<b>45</b>
<b>Appendix H – Curve Numbers .....</b>	<b>46</b>
<b>Appendix I – Hillside Watershed Figures .....</b>	<b>47</b>
<b>Appendix J – Burned Conditions Resources .....</b>	<b>48</b>
<b>Appendix K – Existing Pipe System Analysis .....</b>	<b>49</b>
<b>Appendix L – Land Use and Zoning Maps.....</b>	<b>39</b>

**FIGURES:**

Figure 1. Initial and Major Drainage Systems .....	3
Figure 2. Inlet with Debris.....	38
Figure 3. Direction Flow Grate .....	39
Figure 4. Incorrectly Oriented Directional Grate .....	39
Figure 5. Inspection Program Interface .....	41
Figure 6. 99 Foot Local ROW with Curb.....	57
Figure 7. 55 Foot Rural Local.....	57
Figure 8. Storm Chambers Example.....	61
Figure 9. Projected Population Growth .....	87

**TABLES:**

Table 1. Allowable Spread.....	9
Table 2. Recommended Storm Water Documents .....	15
Table 3. Educational Material and Strategies Proposed Schedule .....	18

Table 5. IDDE Implementation Proposed Schedule .....	20
Table 6. Construction Site Storm Water Runoff Control Proposed Schedule.....	22
Table 7. Long-Term Stormwater Management Policy Proposed Schedule .....	30
Table 8. Good Housekeeping for Municipal Operation Proposed Schedule .....	35
Table 9. Inspection and Cleaning Schedule.....	37
Table 10. Rainfall Design Values .....	43
Table 11. Runoff Coefficients (Rational Method) .....	44
Table 12. Existing Deficiency Costs .....	72
Table 13. User Fee.....	74
Table 14. Future Growth Project Costs.....	79
Table 15. Build-Out Storm Drain ERU Projections .....	88
Table 16. Future Growth Project Costs.....	89
Table 17. Storm Drain Capital Facilities Estimates.....	92
Table 18. Impact Fee Eligible Projects .....	95
Table 19. ERU Annual Projections.....	100
Table 20. Base Impact Fee Calculation .....	101
Table 21. Regional Pond Impact Fee Calculation.....	102



# STORM DRAIN MASTER PLAN

## INTRODUCTION

This storm drain master plan and capital facilities plan has been prepared on behalf of Santaquin City. This document shall be used as a reference for planning, budgeting and development. The document was prepared using the latest available topographic data and storm drain infrastructure data. It was prepared in conjunction with input from the general public as well as other key stakeholders.

## BACKGROUND

Santaquin City is at the crossroads of US Highway 6 (Main Street) and I-15. The town has experienced significant growth in the past 10-15 years. This growth is expected to continue, making Santaquin one of the fastest growing areas in the State. The 2010 Census lists Santaquin City's population as 9,128. By 2040, it is expected to be near 40,000.

## TOPOGRAPHY

Santaquin City is located against the Wasatch Mountains in southern Utah County. Its topography consists of hillside and mountainous areas as well as lowland residential, farmland and orchard areas. Overall, the City slopes from the hillsides to the center of town, and from there, slopes down to the north.

Several Canyons drain into Santaquin including Pole Canyon, Santaquin Canyon, and numerous small-medium canyons located on the east bench of Santaquin including debris basins and an overflow channel. Santaquin Canyon is currently being studied in depth by the Natural Resources Conservation Service (NRCS) and is therefore not extensively addressed in the scope of this report.

The Strawberry-Highline Canal extends from Spring Lake and bends in a northwesterly direction along the north boundary of Santaquin.

The town has a very limited number of drainage outfalls. Prior to the town being settled, Summit Creek flowed through the town creating somewhat of a natural low channel for water to drain toward Utah Lake. The creek's natural path has been filled in and the water from the creek is piped for irrigation purposes. Irrigation ditches line many of the streets in the older parts of town.

## PURPOSE

The purpose of this storm drain master plan document is to provide Santaquin City with a plan for correcting existing storm water deficiencies, and a plan for the needed infrastructure for future development. The document includes recommendations for drainage policy within Santaquin and provides rationale behind those recommendations. As development occurs and time passes, this document must be reevaluated and updated as necessary to provide an up-to-date drainage plan.

## APPROACH TO DRAINAGE IN SANTAQUIN

During the past 25 years, many municipalities have been working toward establishing storm drain systems that collect storm runoff and convey it to a central or regional detention basin. This approach allows maintenance, water quality treatment and discharge points to be at one centralized location.

However, the United States Environmental Protection Agency (USEPA) and Utah Department of Environmental Quality are now imposing requirements that necessitate changing the approach to a retain-on-site approach. This requirement is discussed in more detail in the MS4 and LID Implementation section of this report.

The methods of implementing this requirement are similar to the approach Santaquin City currently uses, which is to intercept storm water and provide a means of retention or infiltration at or very close to the point of interception. There are currently over 440 drainage sumps within the City. There are also several retention basins. For the purposes of this report, a retention basin is defined as a depression or pond that has no outlet for the water except by means of infiltration or evaporation.

The city has several, relatively short trunk lines that convey runoff from newer developments to localized retention basins. The use of long or large diameter trunk lines to convey runoff from one part of the City to another part is generally not recommended as it would require large excavations of existing streets, and would conflict with existing utilities, making it significantly more costly. It is also not in line with the new approach to storm drainage being implemented by the EPA.

## DESIGN GUIDELINES

New developments within Santaquin City must be constructed with an initial and a major storm drain system. The initial system's purpose is to reduce the frequency of street flooding, reduce maintenance costs and provide protection against regularly recurring damage from storm runoff. It consists of curb and gutter, storm drain inlets and pipe and detention basins. The purpose of the major system is to avoid major property damage or loss of life during flood level runoff conditions. This can be accomplished by providing curb and gutter, storm drainage systems and ensuring the ground around new homes slopes away from the home. The major system is comprised of the initial system elements and the entire roadway cross section, including park strip and sidewalk. The initial system must handle the 25-year event, while the major system will handle the 100-year event. The following exhibit details how the initial and major systems must function.

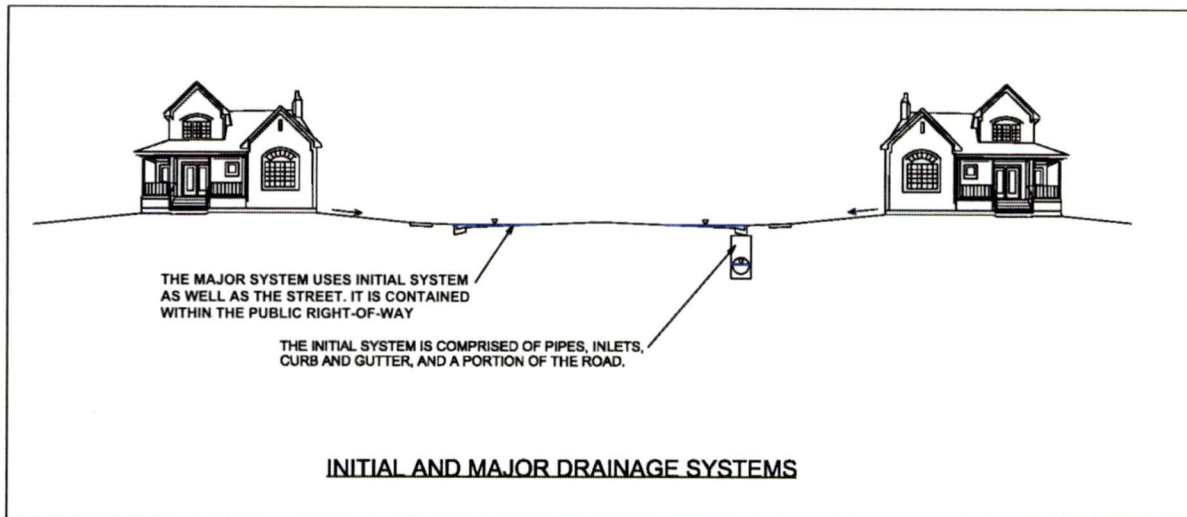

**Figure 1. Initial and Major Drainage Systems**

The maximum water levels for the major system are shown in Figure 1. Initial and Major Drainage Systems should only be considered in flat portions of the city. When the longitudinal slope of a road exceeds 1%, it is unlikely and undesirable that the water would rise to the level shown. Instead, velocities of flow in the street become of primary concern due to the increased potential for damage, and the increased difficulty in controlling such flows. Therefore, in locations where the longitudinal slope of the road exceeds 1%, using the road to handle the major storm is prohibited. Refer to the [Design Storm](#) and [Street Drainage](#) sections of this report and for further details on flow limits.

There are many irrigation ditches located within Santaquin. They currently intercept some of the storm runoff in some portions of the central part of the city. It is likely that the ditches will be piped or filled in at some point in the future and therefore must be ignored and avoided in designing and analyzing drainage systems, unless formally agreed otherwise. Moreover, it is good practice to keep irrigation and storm drains separate in order to maintain water quality, ensure the irrigation system is not overwhelmed, and allow the City to manage its own runoff.

#### HYDROLOGIC METHODS

The Rational method shall be used for sizing pipes and flow rates for inlet grate capacities for localized development. The Rational method must only be used for watersheds that are less than 200 acres. For design elements that require a volume, such as infiltration galleries, retention basin, or debris basin, a unit hydrograph method must be used.

The Rational Method is useful for determining peak flows of a storm event. It uses watershed characteristics and rainfall intensity to predict a flow rate. It is based on the assumption that a steady state is achieved in that the rainfall runoff inflow rate onto a drainage basin is equal to the outflow rate. Steady-state conditions indicate that the storm intensity is uniform spatially and temporally of the drainage basin in question.

The precipitation duration used for the Rational Method must be equivalent to the time of concentration value. The time of concentration is the longest time required for water to flow from any given point within the basin to the outlet (e.g. infiltration basin, detention basin, inlet, etc.). The intensity for duration (IFD) associated with the time of concentration is used in the Rational Method equation.

The Equation for the Rational Method is  $Q = CiA$ .

Where Q = flow rate (cfs)

C = runoff coefficient

i = intensity (in/hr)

A = drainage area (acres)

The units for Q are in acre-inch per hour (ac-in/hr). Because 1 ac-in/hr = 1.0008 cfs  $\approx$  1cfs, this conversion factor can be ignored.

Unlike the Rational Method, unit hydrograph methods account for flow and volume variations over the entire rainfall event. Hydrographs allow the engineer to analyze the effect of storage associated with ponds or retention facilities. If no gauge data is available for a watershed, a hydrograph can be synthesized for various return periods.

## DESIGN STORM

The design storm recommended for use in development and in constructing all City drainage infrastructure is the 25-year storm for sizing pipes, infiltration galleries and retention facilities. These systems function as the initial system. This return event is used because it provides adequate conveyance capacity for the majority of storms but does not cause an undue financial burden that designing for larger storm events would require.

The 100-year storm is considered to be a flood event. The 100-year storm must be used as a check to ensure that flows that exceed the 25-year storm flows can be controlled without causing damage to any adjacent or downstream properties. In other words, the 100-year flows fill up pipes, manholes, inlets, etc. and may flood the road but will be contained within the public right of way and must not cause damage to structures or private property. In cases in which a proposed storm drain system would be adequate for the 25-year flows but 100-year flows could potentially cause property damage or loss of life, the 100-year storm must be used as the design storm. Refer to the [Street Drainage](#) section of this report for further flooding limitations based on road classifications.

It is the responsibility of all developers and designers to demonstrate that any proposed storm drain system is designed for the 25-year event, and controls the 100-year event. This must be clearly documented in a drainage report that accompanies the development application.

## PRECIPITATION DEPTH

The precipitation for each watershed will be taken from the NOAA Atlas 14 Point Precipitation Frequency Estimates Data Server (PFDS).

In mountain watersheds, multiple rainfall event durations will be used for sensitivity analysis. One precipitation depth will be recommended for general city use, and another for evaluating the mountain watersheds, due to greater precipitation depths in those watersheds. The recommended reference locations for depth are included in the Drainage Policies: Design Requirements section of this document. Areal reduction factors will not be considered due to the size of the watersheds being analyzed in the city.

## TEMPORAL DISTRIBUTION

The temporal distribution for a precipitation event relates percentage of total rainfall to percent of duration of the storm. A sensitivity analysis of several distributions was conducted to determine the most appropriate distribution to be used in Santaquin. The distributions used in the sensitivity analysis include Farmer Fletcher, SCS/NRCS Type II, Great Basin Experimental Area, and various distributions from the National Oceanic and Atmospheric Administration (NOAA) for the semiarid southwest region. It was determined that the NOAA 6-hour, 1<sup>st</sup> quartile 20% distribution be used. This distribution provides a reasonable amount of conservatism without grossly underestimating or overestimating volume. Volume is a key design factor for Santaquin since there are very limited outfalls where runoff can be discharged. Because of this, volume becomes the most critical aspect, with the majority of systems being required to store and infiltrate the runoff, rather than controlling the peak outflow as is frequently the controlling factor in storm drainage design.

Further discussion on this selection is outlined below:

1. The NOAA 1<sup>st</sup> Quartile 20% 6-hour exceedance curve for the Semiarid Southwest region will be used for 6-hour storms, which is the recommended duration for use in the city. The 30% curve could be used for storms longer than 6 hours in duration, but longer storms are not anticipated to be required in Santaquin.
  - a. These distributions were developed for the region by NOAA.
    - i. The first quartile is recommended because storms in the first or second quartile are far more likely than storms in the third or fourth quartile in these regions.
    - ii. The 20% and 30% exceedance curves better match the burst type rainfall and orographic effects typical of the Wasatch Front. In addition, the peak flow periods of these NOAA distribution curves are similar to the Farmer-Fletcher (FF) and Great Basin Experimental Basin Area (GBEA) temporal distributions, but do not have the known issues associated with the FF distribution.
      1. The Farmer Fletcher (FF) and Great Basin Experimental Area (GBEA) temporal distributions are used by many municipalities along the Wasatch Front because they were developed based on local Wasatch Front rainfall data. Comparative analysis has shown that these methods

produce peak flows that are neither overly nor insufficiently conservative. But the FF distribution is known to result in lower total runoff volumes than other distributions even though the temporal distribution should not significantly affect the total runoff volume. Because of the volume discrepancy associated with the FF distribution, it is not recommended for use. The FF and GBEA distributions are also not readily available to the industry. (The FF method was developed for storms up to 6 hours in duration, and the GBEA may be used for storms over 6 hours and up to 24 hours. The 2<sup>nd</sup> Quartile distribution would be used for FF, and the 3<sup>rd</sup> Quartile would be used for GBEA.)

2. The NRCS Type II distribution is not recommended because it produces highly conservative peak flows, was developed around a 24-hour event, and was developed for nationwide use. It does not reflect local precipitation characteristics as much as other distributions.

## MINIMUM PIPE SIZE

The minimum pipe diameter to be used in future projects is 18 inches for a trunk line, and 15 inches for lateral pipes, when within public right of way. Although a pipe with a smaller diameter may have sufficient conveyance capacity, using a minimum diameter of 15-18 inches makes cleaning and maintaining the pipe much easier. Moreover, the chance that the pipe will become plugged is reduced when compared to smaller pipes.

## MANHOLE/CLEANOUT SPACING

When located in a storm drain trunk line, the minimum access hole spacing (for inlets and manholes) must be 300 feet for pipes up to 24 inches in diameter, 400 feet for pipes 24-36 inches in diameter and 500 feet for pipes greater than 36 inches in diameter. The access holes provide entry to the underground storm drain system for inspection and cleanout. In addition to these requirements, storm drain access holes must be located where two or more storm drains converge, where pipe size changes occur, and where there is a change in vertical or horizontal alignment.

## RETENTION AND DETENTION SYSTEMS

---

### INFILTRATION GALLERY REQUIREMENTS

Infiltration galleries are subsurface storage/infiltration structures constructed over a layer of free draining granular material. They must be constructed with perforations in the structure wall and a zone of gravel around the infiltration gallery structure to allow storm water to infiltrate laterally out of the structure as well as through its bottom. Infiltration galleries must be designed with a filter fabric to prevent the migration of fines. They must have a non-woven filter fabric or other approved filter system to prevent the migration of fines from the surrounding soils into the drain material. This helps prevent the formation of cavities and settling in the surrounding walls.

The geotextile fabric approved by the City is Mirafi 600X, or approved equivalents. The fabric must surround all sides of the gravel around the infiltration gallery, including the top. No fabric is required below the gravel, except in special circumstances as determined by the City Engineer. The fabric must prevent migration of fines into the gravel, and related settlement of surrounding soils.

When infiltration galleries are constructed, they must have adequate volume for the 25-year, 6-hour event, unless required otherwise (see Retention and Detention Basins section below). A basic geotechnical analysis or percolation test must be performed to determine the suitability of the soils surrounding the gallery.

In cases where no outfall is available, the system as a whole must be designed to store and infiltrate the complete 100-year storm. Alternative infiltration systems (e.g. R-Tanks, Storm Tech Chambers, etc.) will be considered on a case-by-case basis. A means of preventing deposition of trash and sediment into the system must be employed. Any infiltration system must have a means provided for regular maintenance such as cleaning or flushing. Design of infiltration basins must accommodate some sedimentation and the accompanying loss of volume. Mirafi 600X geotextile fabric must also be used around the sides and top of any alternative infiltration system to prevent migration of fines.

Infiltration galleries are not to be located within any part of the roadway. The maximum water surface elevation within the infiltration gallery must be at least two feet below the pavement section of any adjacent road. The galleries must be located at least five feet behind the curb and gutter. Sumps, defined herein as perforated, open-bottomed manholes or inlet structures, are no longer allowed as a viable option for containing storm runoff volumes. They simply do not have adequate volume for design storms, do not provide pre-treatment of runoff, and present multiple maintenance challenges.

In order to adhere to current Municipal Separate Storm Sewer System (MS4) requirements, retention basins must be constructed with a pretreatment structure. One example of a pretreatment method is a fore bay constructed at the location where a storm drain pipe discharges into a retention basin. The fore bay is separated from the rest of the pond by a short berm, and functions to collect debris, sediment and trash prior to entering the main part of the basin. Infiltration galleries must also be constructed with a pretreatment manhole. The pretreatment manhole must have a water quality hood and a deep chamber to intercept pollutants. The pretreatment structures must be easily accessible for maintenance purposes. A storm-chamber type infiltration gallery must be constructed with an isolator row. The isolator row is lined with a geotextile fabric and is accessible by means of a manhole for removing debris with a water jet.

---

## RETENTION AND DETENTION BASINS

Retention and detention basins shall be designed with consideration to storage volume, public safety and maintenance. The basins must have side slopes no steeper than 4H:1V. When depths exceed five feet, the basin must be "stepped" at five foot intervals to allow someone inside the basin to more easily climb out of it. The City Engineer may approve variances on these requirements only in very limited circumstances based on site and public safety considerations. In accordance with current city code,

basins with a depth greater than three feet shall be constructed with a fence high enough to prevent entrance to the basin.

Although there will likely be infiltration from the basins during the runoff event, they must be designed with adequate volume without considering infiltration (i.e. no release rate). Aboveground basins must be constructed with at least one foot of freeboard from the water surface elevation to the top of the basin, or emergency spillway, whichever is lowest. Aboveground basins or basins that rely on a berm on one side are likely to have problems with piping, leakage, and catastrophic failure, and shall not be allowed unless otherwise approved by the City Engineer.

If extenuating circumstances make berms necessary, they must be constructed to industry standards for dams, and must meet the standards of the State of Utah for Dam Safety. A geotechnical engineer, hydrologist, and hydraulics engineer experienced in dam design and construction must be consulted and must stamp any design.

MS4 permits for most small municipalities within Utah will require that new development or redevelopment projects prevent any off-site discharge of precipitation from all rainfall events less than or equal to the 90<sup>th</sup> percentile rainfall event. Although this requirement does not apply to Santaquin at this time, it is anticipated that Santaquin will become part of the Utah Pollutant Discharge Elimination System (UPDES) permit in the near future. All new developments within the city must demonstrate how they are meeting this requirement at the time that Santaquin is included in the permit. Typically, the 90<sup>th</sup> percentile storm will be handled by default because nearly all development in Santaquin will be requiring containment of the much larger 25-year storm, at a minimum.

The 90<sup>th</sup> percentile storm event is defined as the precipitation event whose precipitation total is greater than or equal to 90 percent of all storm events over a given period of record. For most MS4s in Utah, the 90<sup>th</sup> percentile depth is between 0.6-0.7 inches. An analysis was completed to determine the depth for Santaquin City. Daily precipitation data was obtained for the Chlorinator Station location. Snowfall events and rainfall events with depths less than 0.1 inches were removed from the analysis per Utah Department of Environmental Quality's recommendations, as these events do not immediately produce any runoff. The 90<sup>th</sup> percentile depth for Santaquin is 0.70 inch.

The 25-year event is the event that corresponds to an average return period of 25 years. It may also be described as the four percent chance storm, meaning that in any given year, there is a 4% chance of a storm of a given magnitude occurring.

Measures installed upstream of a retention basin which reduce runoff may be used as justification to reduce the volume required in retention basins, unless the capacity of such runoff reduction measures can reasonably be expected to fail without proper maintenance. In such cases, no volume reduction shall be accounted for when determining the overall size of retention systems. Without sufficient maintenance, it is not guaranteed that the volume of certain runoff reduction measures will be maintained and be usable as time goes by. The City Engineer will ultimately determine whether such measures can be expected to fail.



Retention and detention basins shall be designed to handle the 25-year storm, as specified in the hydrology sections of this report. If there is no available outfall to convey the 100-year runoff event, the system is required to contain the full volume of the 100-year event. If the city has a regional 100-year retention or detention facility constructed downstream of the site as part of this master plan, and the developer can demonstrate how the flows beyond the 100-year storm can reasonably reach that basin without adversely affecting other private property and city infrastructure (unless mitigated by the developer), then retention of the 100-year event volumes for that development above and beyond the 25-year storm may occur downstream of the development in the master planned regional retention facility. The 25-year volume must be retained on site even if such regional facilities are available.

If there is an outfall, it is recommended that the outflow be limited to the peak runoff rate of the 10-year storm in existing conditions, or to the capacity of the drainage system below considering all other demands on that system. Many municipalities limit the outflow to a specific rate of peak discharge per acre to roughly match pre-existing conditions, or system capacities. However, because detention in Santaquin appears generally to be the exception, with retention being used most prominently, detention discharge rates will be considered and approved on a case-by-case basis. If detention is used, the release rate must be limited to the existing flow rate for the 10-year event, or the capacity of the downstream system, whichever is smaller.

Retention basins that are located on private property (i.e. with a storm drain easement rather than a lot or parcel dedication) must have all storage and infiltration underground in facilities such as R-Tanks or Storm Tech Chambers such that the property owner may more fully utilize the property. Two feet of cover must be provided over the top of the underground infiltration system. Any exceptions or variations must be reviewed and approved.

## STREET DRAINAGE

Streets play a significant role in a storm drain system. The degree to which streets may be used for storm runoff is to be governed by the street classification. Streets with a lower travel speed may have a greater degree of water ponded on them without causing safety problems associated with hydroplaning. The extent that water encroaches onto the pavement is referred to as spread.

From a traffic and safety standpoint, the following criteria apply: During the 100-year design storm, local streets may have a water depth up to the crown of the street. Collector streets must have at least one full lane free of water; and arterial streets must have one lane free of water in each direction.

**Table 1. Allowable Spread**

Road Classification	Allowable Spread (100-year storm)
Local Streets	To crown of road
Collectors	To half of lane (equivalent width of one full lane open)
Arterials	One lane in each direction open

These criteria only apply to streets with longitudinal slopes of 1% or less. Other criteria apply that will supersede the allowable spread on steeper streets, such as placing inlets at intersection corners to minimize bypass, velocity limits, and flooding of downstream properties.

#### BENCH AREA (HILLSIDE DEVELOPMENT)

As development occurs on the east bench or other hillside areas, consideration must be given as to how storm water is retained. Constructing a retention/infiltration basin on a hillside generally requires a cut on the upper side and a fill on the lower side of the basin. Any artificial barrier that impounds or diverts water above existing ground is considered a dam, per Utah Administrative Code R655. If a retention basin is located above properties that are or may become developed, it may be classified as a high hazard dam and be subject to Utah Dam Safety jurisdiction. For this reason and for the safety of the public, retention basins on hillsides should only be considered on a case-by-case basis. Their location and geometry should be such that if they were to fail, damage to downstream infrastructure will be minimized. Typical mitigation elements for a breach may include an emergency spillway, and routing systems, etc. The need for such elements would be fully analyzed and designed in conjunction with the development permit application and Utah Dam Safety requirements. A detailed geotechnical analysis must be conducted in all cases.

---

#### BURNED CONDITIONS AND DEBRIS FLOWS – GENERAL

As is well known in Santaquin, there is a strong probability that residential development on the bench areas may be subject to debris flows. This occurs when vegetation in the hillside canyons is burned, leaving bare soil, and a high-intensity rainstorm occurs. Where runoff was once abstracted by vegetation, the additional direct precipitation loosens the soils causing large amounts of soil, mud, stone and water to travel downstream.

All Development which occurs downstream of a canyon watershed will be required to study, address, and provide mitigation measures for potential debris flows or other flooding hazards identified, or demonstrate why no significant hazard exists.

Santaquin City code contains development standards for Hillside Overlay Zones. Section 10-7Q-6 details specific requirements for sensitive area mitigation and analysis, including flood and watershed protections studies, and geological hazard mitigation.

---

#### BURNED CONDITIONS AND DEBRIS FLOWS – PLANNING

Volumes for debris flows and runoff are provided later in this report. However, a detailed drainage study for each location must be prepared by the developer and provided to the city for review as development occurs.

A minimum of three scenarios must be analyzed for the design of all proposed storm drainage infrastructure:

- 100-year storm utilizing the standard city criteria as required elsewhere in this report.

- 25-year storm under burned conditions with flows bulked based on sediment concentrations.
- Debris flow analysis using current state of practice techniques, and as outlined below. For planning level analysis, a 5-year 1-hour event shall be used, with burn severity from the Mollie Fire as a design basis.

The NRCS recently awarded funds to Santaquin City to develop a plan-environmental assessment (Plan-EA). The Plan-EA will include 30% level design and the necessary footprint to produce an environmental assessment document for six debris basins. It is anticipated that the City will obtain further NRCS funding in the future to complete full construction drawings and to construct needed facilities.

---

## POST FIRE HYDROLOGY

Multiple sources addressing post-fire runoff were examined in order to make a recommendation for master plan design criteria, potential design code, sediment loads, and debris flow analysis. It is noted that this field of study is still in development. Therefore, the design techniques have some uncertainties. The most thorough and relevant treatments known at this time are the design manual from Los Angeles County, the NRCS Technical Note No. 4, and relevant scholarly articles by Santi et al (2007), Prochaska et al (2008), Cannon (2010), Gartner (2008), "Suggested Changes to AGWA to Account for Fire" (Canfield & Goodrich, USDA-ARS, 2005), and publications from the Utah Geological Survey. A mix of the information provided therein is recommended for implementation in Santaquin. As the field of study develops, the burden is upon the Developer's Engineer to prove to the City Engineer that such is reasonable, sufficiently developed, and applicable for application in any proposed study.

---

## RECOMMENDATIONS

Under burned conditions, the current consensus among experts is that the peak flows increase significantly due to the reduction in the time of concentration, but total runoff volume increases are not as significant. Past practice has been to decrease the infiltration (i.e. increase the runoff) to model post-fire conditions. It is recommended that studies use the following guidelines in developing post-fire runoff studies:

- Adjust the Curve Number (CN) using the Table 9.1 in the USDA-ARS document "Suggested Changes to AGWA to Account for Fire" (2005), or one of the tables in NRCS TN#4. Other sources may be considered.
  - Note:
    1. Post-burn runoff volumes should not be dramatically different from runoff under typical conditions, as discussed in the USDA-ARS document previously cited, so CN changes should not be large.
    2. In determining a CN, it shall be taken in to consideration that generally the entire watershed does not have severe burn severity. In the Mollie Fire only 29.3% of the burn area was moderate to severe, though this varied between individual watersheds.

- Adjust Manning's n for post-fire conditions in time of concentration (Tc) calculations per recommendations in the USDA-ARS document "Suggested Changes", and NRCS TN No. 4. Manning's "n" for near bare soil condition immediately following a fire may be as low as n = 0.011 (Applicable to velocity time of concentration method).
- If using the NRCS dimensionless unit hydrograph, a higher peak factor may be considered if satisfactory justification is provided (see pg. 24-27 of TN No. 4). Use of a kinematic wave model (KINEROS2 in AGWA, HEC-HMS) must also be considered.
- Use Bulking Factor formula in NRCS TN No. 4 to adjust final volume. A volume of transported sediment must be calculated or assumed to apply the bulking factor.

#### Sediment Volume:

- Sedimentation models for burned condition analysis must be event based. KINEROS2 (AGWA) model is an event-based model (NRCS TN No. 4). Other long-term erosion methods and programs such as WEPP and RUSLE2 are not recommended for burned condition analysis.
- Apply an assumed sediment load such as 20% only with approval of city engineer (20% has been suggested in relevant publications as the approximate border between normal flow and hyperconcentrated flow).

#### Post-Fire Debris Flows:

Debris flows may be analyzed based on a combination of potential volume of debris flow, and the probability of a debris flow occurring. Examining both probability and potential volume can give a fuller picture of the potential threat of damaging debris flows.

#### Analysis for Probability of Debris Flows:

- Recommend formula in document published by UGS, "Predicting the Probability and Volume of Post Wildfire Debris Flows in the Intermountain Western United States" recommended by the UGS (Cannon, 2010).
- The Mollie Fire is recommended as the source for burn severity data. GIS burn severity data is available from the USGS Monitoring Trends in Burn Severity (MTBS) project.
- The percent of area the total area of the Mollie Fire area burned at moderate to high severity used in model is 29.3%. This value was used in the planning level analysis.

#### Analysis of Volume of Debris Flow:

- Use Gartner (2008) debris material volume formula for burned basins to determine volume of material
- Use a short duration (1-hr or equivalent), frequent storm precipitation (2 to 10 years) in analysis. UGS has found that the majority of debris flow events occur from relatively frequent storms. The 5-year storm has been used in the master planning analysis.

---

## DEBRIS BASIN DESIGN RECOMMENDATIONS:

It is recommended that the final design of debris basins generally follow the criteria in the LA County Sedimentation Manual, with modifications as recommended in Prochaska (2008), and as outlined below:

- Use basin volume requirements for debris flows (i.e. may account for slope of deposited sediment in designing dimensions of debris basin where applicable)
- Consideration of mitigation structure type must be done based on sediment yields as generally outlined in Table 4.1.1 in the LA Manual. The City Engineer shall approve the type of structure proposed.
- Debris racks or similar measures must also be considered in watersheds less than 2 km<sup>2</sup> (≈0.8 mi<sup>2</sup>). This may allow elimination of basins, or reduction in size, or may be used in minor channels. Debris racks should be installed in series of two or more racks unless approved otherwise. Design per input in Santi (2007, pg. 7-8).
- Meet basin dimensions requirements to prevent “momentum overflow” from LA Manual, as modified by Prochaska (upstream slope, runup calculations)
- Meet debris barrier recommendations by Prochaska, using impact force formula and recommended spacing, per style shown in LA Manual
- Deflection Berms to meet recommendations of Prochaska, such as sizing, height, stability, etc.
- Riprap sizing per Prochaska (Table 4).
- 3 feet freeboard per FEMA
- Basin volume must account for normal sediment volumes expected during the runoff event, and sediment accumulated between anticipated periods of sediment removal

---

## RECOMMENDED BURNED CONDITION RESOURCES

The following resources shall be referenced when analyzing hydrology and debris flow in burned conditions in Santaquin, as well as more current research that meets high standards for reliable studies.

- USDA, NRCS, 2016, *Hydrologic Analyses of Post-Wildfire Conditions*, Hydrology Technical Note No. 4
- UGS and USGS publications,
  - “Predicting the probability and volume of post wildfire debris flows in the intermountain western United States” (Cannon, et al, USGS, 2010)
  - “The 2000-2004 Fire-Related Debris Flows in Northern Utah” (Giraud & McDonald, UGS)
  - “Guidelines For Investigating Geologic Hazards and Preparing Engineering-Geology Reports, With a Suggested Approach to Geologic-Hazard Ordinances in Utah” (Bowman and Lund, 2016)
  - “Estimation Of Potential Debris-Flow Volumes for Centerville Canyon, Davis County, Utah” (Giraud and Castleton, UGS, 2009)
- USDA-ARS, Canfield and Goodrich, 2005, *Suggested Changes to AGWA to Account for Fire (V. 2.1)*
- LA County Sedimentation Manual, 2<sup>nd</sup> Edition, 2006
- Prochaska, A. B., Santi, P. M., and Higgins, J. D., 2008, Debris Basin and Deflection Berm Design for Fire-Related Debris-Flow Mitigation: *Environmental & Engineering Geoscience*, Vol. XIV, No. 4, pp. 297-313.
- Santi, et al., 2007, Effectiveness of Debris Flow Mitigation Methods in Burned Areas

## MS4 AND LID IMPLEMENTATION

The Federal Clean Water Act requires that storm water discharges from certain entities or facilities be authorized under storm water discharge permits. The State of Utah was granted the authority to execute and enforce its own program by the US Environmental Protection Agency in the National Pollutant Discharge Elimination System program. Utah's program is known as the Utah Pollutant Discharge Elimination System (UPDES), and is administered by the Utah Division of Water Quality (DWQ). The objective of the permit is to reduce the amount of pollutants entering streams, lakes and rivers. The permits issued to municipalities stipulating the conditions of their permitted discharge are referred to as municipal separate storm sewer system (MS4) permits.

Santaquin City is not yet required to adhere to the requirements of a MS4 permit. However, it is anticipated that the City will be included in 2020 UPDES permit renewal. The City desires to implement practices and ordinances now in order to begin preparing to develop a storm water management plan and to meet the MS4 permitting requirements. The following provides specific recommendations and guidelines for the implementation of MS4 requirements by the City.

---

### STATUS AND EXPECTATIONS FOR ENFORCEMENT OF MS4 PERMITS IN UTAH

The Utah Division of Water Quality is the agency tasked with enforcing storm water discharge permits in Utah, and has currently limited enforcement to midsize and large municipalities, metropolitan areas, and government and quasi-government agencies. Permits have required that acceptable practices be established addressing the six minimum control measures, required by the UPDES permit. No specific quantified limits on pollutants have been established, nor has any program of testing pollutant quantities been universally applied.

#### **TMDL Testing**

The Division is in the process of establishing a program that will require the measurement of specific pollutant levels in storm water discharge, and once it has sufficient data, the agency will include quantified total maximum daily loads (TMDL) in the permits, depending on the status and nature of the receiving waters. Groundwater pollution from concentration of pollutants in storm water facilities has not yet been extensively addressed in these programs, but concerns over such are currently under discussion in government agencies and the industry.

Utah is taking a prioritized regional approach to implementation. Specific TMDL limits are currently being studied and established for the Jordan River. It is anticipated that the next body of water the State intends to address is Utah Lake, which would likely include communities that indirectly affect the lake. Santaquin has never directly discharged storm water or wastewater effluent into the lake, or tributaries thereof.

## State Storm Drain and LID Manual

The DWQ is also in the initial stages of preparing a storm water and Low Impact Development (LID) manual. They will be hiring a consulting firm to develop the manual. It is recommended that when this manual is complete that the recommendations included herein be reviewed and updated to reference and implement the State's design manual recommendations as deemed necessary.

### DOCUMENTS REQUIRED FOR STORMWATER MANAGEMENT AND MS4 IMPLEMENTATION

A complete storm water management program as commonly applied in communities similar to Santaquin often includes several or all of the documents as listed below, separately or combined. This document is prepared to encompass the Storm Water Master Plan, Capital Improvement Plan, Impact Fee Facility Plan, and contains storm drain policy that may take the place of putting the policy in city code. This document also contains much of what would be included in a Storm Water Management Plan. The Storm Water Management Plan is a document submitted yearly to the Division of Water Quality to show compliance with the MS4 permit provisions.

**Table 2. Recommended Storm Water Documents**

<b>Document</b>	<b>Description</b>
<b>Storm Water Master Plan</b>	Models system and identifies deficiencies and future needs to meet storm water demands.
<b>Storm Water Capital Facilities Plan</b>	Identifies costs, priorities, and schedules of implementation for needed projects for existing deficiencies and needs for future growth.
<b>Impact Fee Facility Plan</b>	Quantifies the impact of development both on existing facilities and needed future facilities. Impact fees are determined for developers based on state code.
<b>Ordinances</b>	Specify generally the storm water requirements that developers, residents, businesses and the city itself must meet. Typically references other documents for specific requirements and recommendations for implementation.
<b>Storm Water Design Manual</b>	Provides specific data, requirements, and recommendations for storm water design within the city, including pollution prevention measures. May include Low Impact Development design requirements and methods.
<b>Standard Specifications and Drawings</b>	Specify specific requirements for the construction and installation of improvements within the city
<b>Storm Water Management Plan</b>	Document defining means, methods, and results of management of storm water and related contaminants. This document must be submitted yearly to the Division of Water Quality.
<b>Standard Operating Plan (Illicit Discharge Detection and Elimination)</b>	Plan outlining means and methods to identify and address illicit discharges

This Storm Water Master Plan will describe specific MS4 and LID practices and general storm drain design standards that are recommended for implementation, but is not a substitute for the other documents typically required for a complete program.

## MINIMUM CONTROL MEASURES

There are six minimum control measures included in the small municipalities MS4 permit. They include

1. Public Outreach and Education,
2. Public Participation and Involvement,
3. Illicit Discharge Detection and Elimination,
4. Construction Site Storm Water Runoff Control,
5. Long-term Storm Water Management in New Development and Redevelopment,
6. Pollution Prevention and Good Housekeeping for Municipal Operations.

In addition, in order to prevent the unnatural increase and concentration of discharge from urbanization and the concentration of pollutants associated with it, as part of long-term storm water management control, it has been determined new developments or redevelopment projects must prevent the offsite discharge of the 90<sup>th</sup> percentile storm. This requirement will become effective March 1, 2019. This reduction in runoff from each site can also reduce the demand and size of regional storm drain systems. Further detail on how to quantify the 90<sup>th</sup> percentile storm is provided by the State in the document "DWQ Guidance for Calculation of 90<sup>th</sup> Percentile Storm Event", which is available on their website.

---

## APPLICATION OF BEST MANAGEMENT PRACTICES

Best Management Practices (BMPs) is a phrase used to describe a method of storm water pollution prevention or control that best applies to the situation and circumstances. To be in compliance, the City must establish minimum standard BMPs to meet each part of the six minimum control measures. These apply to development, redevelopment, long-term (post construction) water quality, and for city operations and maintenance practices. In some cases, ordinances must also be adopted requiring the implementation of BMP's, so as to be clearly enforceable.

Cost, degree of maintenance, and overall effectiveness are all qualities that must be considered when selecting a BMP. BMPs are typically thought of as controls installed during construction. However, pollution prevention must be considered in all activities within a municipality.

The following pollutants are commonly generated by residents or businesses within a City. They must be considered in the implementation of BMPs. This list covers the most common pollutants, but is not an all-inclusive list.

Pollutants to address:

- Fertilizers and Pesticides
- Total Phosphorus (often from fertilizers)



- Nitrogen (often from fertilizers)
- Total Dissolved Solids
- Sediment from construction and other sources
- Litter
- Motor Oil
- Yard clippings
- Soapy car wash water
- Animal waste

## MINIMUM CONTROL MEASURE RECOMMENDATIONS

The minimum control measures and BMPs recommended for implementation by the City are described below. A review of current city ordinances and standards and recommended changes are provided in the “Drainage Policies” portion of this master plan.

### 1 - PUBLIC EDUCATION AND OUTREACH

It is recommended that the following public education and outreach methods be implemented or considered for implementation

**Forming Partnerships:** Partnerships with other entities that may contribute to storm water pollution within the city or to shared waters (including groundwater aquifers) is advisable or may be essential in order to be effective. Entities with which Santaquin should consider collaborating include:

- Summit Creek Irrigation Company
- Genola
- Spring Lake (unincorporated community)
- Utah County
- UDOT
- Highline Canal
- Utah County Storm water Coalition – a number of communities in Utah County have joined together to develop a storm water management program to reduce the negative impacts of storm water pollution and meet the requirements of the MS4 permit for public education and outreach.

**Using Educational Materials and Strategies:** Understanding and participation of the general population is essential to the success of any program to reduce illicit discharges, and to engender support for efforts and expenditures to address storm water issues. Selecting means of control amenable to citizens is also necessary. It is recommended that the city consider participation in the following means of public education and outreach, or similar activities (See Table 3). Practices must have measureable goals and set schedules for implementation.

**Table 3. Educational Material and Strategies Proposed Schedule**

<b>Best Management Practice (BMP)</b>	<b>Measurable Goal</b>	<b>Implementation Schedule</b>
<b>A. Develop Web Based Educational Program</b>	Include New Educational Material Monthly on City Web Site	Monthly
<b>B. Distribute Flyers for Institutional, Industrial and Commercial</b>	Include Flyers With Business License Renewal	Annually
<b>C. Distribute Flyers in Utility Bills</b>	Distribute Flyers to all Utility Bill Recipients	Annually
<b>D. Include Material in City Newsletter</b>	Include Educational Material in City Newsletter	Annually
<b>E. Distribute Materials in Public Locations</b>	Have materials available at public facilities and at public events	Continuously/As applicable
<b>E. Join and Support Utah County Storm Water Coalition</b>	Document School Education Programs Conducted by Coalition	Annually
<b>F. Employee Training</b>	Conduct Training for City Employees	Annually
<b>G. Measure Program Effectiveness</b>	Web site and water bill survey	Every Five Years

---

**2 - PUBLIC PARTICIPATION AND INVOLVEMENT**

Table 4 shows a summary of Best Management Practices (BMP's) for Public Participation and involvement to be considered for implementation by the city. These or similar programs must be in place to comply with the public participation and involvement requirements of the MS4 permit.

**Table 4. Public Participation and Involvement Proposed Schedule**

Best Management Practice (BMP)	Measureable Goal	Implementation Schedule
<b>A. Use Citizen Advisory Committees</b>	Request Input From Neighborhood Committees and Chamber of Commerce	Annually
<b>B. Make Storm Water Pollution Prevention Documents and Information Available to the Public</b>	Post Documents and Information on Web Site  Distribute Flyers at Town Carnival	Annually
<b>C. Allow Public Review of Annual Reports</b>	Post Annual Reports on Web Site	Annually
<b>D. Conduct Public Hearings</b>	Hold annual public hearing once MS4 permit is active; may be at City Council meeting or other public meeting designated for this purpose	Annually (Once city specific permit is issued)

The following are additional suggestions for public participation and involvement (Source: EPA's document titled "Phase II Public Participation/Involvement Minimum Control Fact Sheet"). The public should be made aware of and be a participant of a clean environment through education activities.

**Public Meetings:** allow residents to discuss various viewpoints and provide input regarding storm water management policies.

**Volunteer Water Quality Monitoring:** provides citizens with firsthand knowledge of the quality of local water bodies.

**Storm Drain Stenciling:** a simple activity that provides a visual reminder of the importance of water quality. It consists of painting warnings and reminders on curb and gutter, sidewalk, or the pavement near a storm drain inlet. A typical message would be "No Dumping, Drains to River" or "We All Live Downstream".

**Community Clean-Ups:** along local waterways and around storm drains involve the public and provides a way for residents to get involved.

**Citizen enforcement:** provide means for citizens to identify polluters or share observations and concerns, such as an online reporting webpage.

---

### 3 - ILLICIT DISCHARGE DETECTION AND ELIMINATION (IDDE)

An IDDE program is required to systematically find and eliminate sources of non-storm water discharges. The following activities and documents need to be developed and maintained. A typical recommended implementation and activity schedule is included below in Table 5.

**Storm Sewer Map:** A map needs to be developed and maintained showing how wet and dry weather flows may enter the storm water system.

**Legal Prohibition and Enforcement:** Santaquin City should develop an ordinance to restrict illicit discharges. The ordinance must be enforced and modified as necessary. See ordinance Drainage Policies portion of this plan for further recommendations.

**A Standard Operating Plan:** The plan must include methods to locate problem areas, determine the actual source of the illicit discharge, and method to remove or correct sources of illicit discharges.

**Table 5. IDDE Implementation Proposed Schedule**

Best Management Practice (BMP)	Measureable Goal	Implementation Schedule
System Mapping	Update Maps	Annually
Storm Water Ordinance	Review Ordinance	Annually
	Update Ordinance	As-needed
Procedures to Detect and Address Non-storm Water Discharges	Develop and Update Standard Operating Procedures (SOP)	Annually
	Inspect High Priority Areas	Annually
	Inspect 20 % of outfalls	Annually
		As-needed

<b>Best Management Practice (BMP)</b>	<b>Measureable Goal</b>	<b>Implementation Schedule</b>
	Notify Division of Water Quality if separate discharge permit is required	
<b>Procedures to Trace Source of Illicit Discharge</b>	Review SOP Update SOP	Annually As-needed
<b>Procedures to Characterize Illicit Discharge</b>	Review SOP Update SOP	Annually As-needed
<b>Procedures to Cease Illicit Discharge</b>	Review SOP Update SOP	Annually As-needed
<b>IDDE Education</b>	Provide Training	Annually
<b>Household Hazardous Waste Program</b>	Provide Program	Annually
<b>Illicit Discharge Hotline</b>	Advertise Number	Annually
<b>Spill/Dumping Response</b>	Review SOP Update SOP	Annually As-needed
<b>Training</b>	Storm Drain Employees Field Staff and office Personnel	Annually Annually
<b>Program Evaluation and Assessment</b>	Review SOP Update SOP	Annually As-needed

#### 4 - CONSTRUCTION SITE STORM WATER RUNOFF CONTROL

Best Management Practices for construction must be implemented for all development and city projects. Recommended BMPs and requirements for Storm Water Pollution Prevention Plans (SWPPP) are outlined in this manual. Enforcement plans must be detailed in the city's Standard Operating Plan (to be developed). Regular training for city personnel in the practice and inspection of these BMPs shall be provided. A typical proposed schedule for implementation is provided below.

**Table 6. Construction Site Storm Water Runoff Control Proposed Schedule**

Best Management Practice (BMP)	Measureable Goal	Implementation Schedule
Ordinance to Require the Use of Erosion and Sediment Control Practices at Construction Sites	Review Ordinance Update Ordinance	Annually As needed
Prepare detailed requirements and list of recommended BMPs as part of Storm Water Technical Manual	Prepare Technical Manual Review Manual Update Manual	12 Months from MS4 Inclusion Annually As Needed
Enforcement Strategy	Develop SOP Review SOP Update SOP	12 Months from MS4 Inclusion Annually As needed
SWPPP Review	Develop SOP Review SOP Update SOP	18 Months from MS4 Inclusion Annually As needed
Construction Site Inspection	Develop SOP Review SOP Update SOP	12 Months from MS4 Inclusion Annually As needed
Training of Review and Inspection Staff	Employees Third-party Plan Reviewers and Site Inspectors	Annually Annually
Record Keeping	Develop SOP Review SOP Update SOP	18 Months from MS4 Inclusion Annually As needed

#### RECOMMENDED CONSTRUCTION BEST MANAGEMENT PRACTICES.

Included below are the top ten Construction BMPs as listed on the Utah Department of Environmental Quality (<https://documents.deq.utah.gov/air-quality/fact-sheets/DAQ-2018-001484.pdf>). These are minimum requirements to be considered and implemented in all development work, SWPPP plans, and city projects. A full list of potential BMPs should be included in the development of a Storm Water Technical Manual.

Final selection of appropriate BMPs for the site rests upon the developer and the contractor, and may include BMPs not included in the lists provided in this Plan or in the proposed Storm Water Technical Manual. The contractor is ultimately responsible to install and maintain those BMPs that are most suitable to control runoff, prevent erosion, and contain potential contaminants.

**Preservation of Existing Vegetation:** Preserving existing vegetation minimizes the disturbance area, and the amount of exposed soil. It also reduces soil erosion.

**Construction Phasing:** By phasing the construction, the developer ensures that the minimum required area is disturbed. In cases in which the development ceases or is not completed, a smaller area is left disturbed, which reduces the potential of soil erosion.

**Construction Entrances:** Construction Entrances remove mud from vehicles wheels prior to exiting the construction site and entering public roadways that drain to storm drain systems.

**Silt Fencing:** Silt fences capture soil that has eroded so that it does not travel outside of the construction site or enter downstream storm drain systems or waterways. Other products such as waddles provide similar benefits, but all of these are highly dependent upon proper installation, and must be inspected by an individual trained in proper installation methods.

**Storm Drain Inlet Protection:** Inlet barriers may be construction of silt fence, straw wattles, rock bags or a filter beneath the grate. These serve as a last line of defense and must not serve as the primary storm drain protection.

**Vegetative Buffers:** Vegetative buffers should be protected or installed along waterbodies to slow and filter storm runoff.

**Site Stabilization:** The construction site must be stabilized within 14 days after land alterations have been completed. The stabilization methods may include hydroseeding, placing turf sod, riprap, erosion control mats, etc.

**Equipment Fueling and Containment:** The use of offsite fueling stations will prevent the potential for fuel to spill onto the construction site. Any dedicated fueling area must be level and away from waterbodies, and must have spill containment features.

**Waste Management:** Waste management includes the use of concrete washout facilities, using covered waste containers, proper handling and containment of hazardous waste, and not allowing waste to accumulate on site.

**Fugitive Dust Suppression:** Dust can be suppressed by watering down haul roads, restricting vehicle speeds to 10 mph, reducing size and number of excavations and watering down equipment and excavation faces.

---

## SWPPP SUBMITTAL REQUIREMENTS

SWPPPs are required for projects that will disturb one or more acres of land, or will disturb less than 1 acre of land but be part of a common plan of development or sale that will ultimately disturb one or more acres of land.

All SWPPPs submitted for review in Santaquin City must adhere to the requirements of the Utah Pollutant Discharge Elimination System (UPDES) permit requirements. The following required contents are taken from the UPDES Construction General Permit (<https://deq.utah.gov/Permits/water/updes/stormwatercon.htm>):

**Storm Water Team:** Each owner/operator must assemble a “storm water team,” which is responsible for overseeing the development of the SWPPP, any later modifications to it, and for compliance with the requirements in this permit.

The SWPPP must identify the personnel (by name or position) that are part of the storm water team, as well as their individual responsibilities. Each member of the storm water team must have ready access to an electronic or paper copy of applicable portions of the permit, the most updated copy of the SWPPP, and other relevant documents or information that must be kept with the SWPPP.

**Nature of Construction Activities:** The SWPPP must describe the nature of your construction activities, including the size of the property (in acres) and the total area expected to be disturbed by the construction activities (in acres), construction support activity areas covered by the permit, and the maximum area expected to be disturbed at any one time.

**Emergency-Related Projects:** If you are conducting earth-disturbing activities in response to a public emergency, you must document the cause of the public emergency (e.g., natural disaster, extreme flooding conditions, etc.), provide information substantiating its occurrence (e.g., state disaster declaration or similar state or local declaration), and provide a description of the construction necessary to reestablish effected public services.

**Sequence and Estimated Dates of Construction Activities:** The SWPPP must include a description of the intended sequence of construction activities, including a schedule of the estimated start dates and the duration of the activity, for the following activities:

- a. Installation of storm water control measures, and when they will be made operational, including an explanation of how the sequence and schedule for installation of storm water control measures complies with the permit, and of any departures from manufacturer recommendations;
- b. Commencement and duration of earth-disturbing activities, including clearing and grubbing, mass grading, site preparation (i.e., excavating, cutting and filling), final grading, and creation of soil and vegetation stockpiles requiring stabilization;
- c. Cessation, temporarily or permanently, of construction activities on the site, or in designated portions of the site;



- d. Final or temporary stabilization of areas of exposed soil. The dates for stabilization must reflect the applicable deadlines to which you are subject in the permit; and
- e. Removal of temporary storm water conveyances/channels and other storm water control measures, removal of construction equipment and vehicles, and cessation of any pollutant-generating activities.

**Site Map:** The SWPPP must include a legible site map, or series of maps, showing the following features of your project:

- a. Boundaries of the property and of the locations where construction activities will occur, including:
  - i. Locations where earth-disturbing activities will occur, noting any phasing of construction activities;
  - ii. Approximate slopes before and after major grading activities. Note areas of steep slopes;
  - iii. Locations where sediment, soil, or other construction materials will be stockpiled;
  - iv. Locations of any crossings of surface waters;
  - v. Designated points on the site where vehicles will exit onto paved roads;
  - vi. Locations of structures and other impervious surfaces upon completion of construction; and
  - vii. Locations of construction support activity areas covered by this permit.
- b. Locations of all surface waters, including wetlands, that exist within or in the immediate vicinity of the site. Indicate which water bodies are listed as impaired, and which are identified as Category 1 or 2 waters;
- c. The boundary lines of any natural buffers provided.
- d. Topography of the site, existing vegetative cover (e.g., forest, pasture, pavement, structures), and drainage pattern(s) of storm water and authorized non-storm water flow onto, over, and from the site property before and after major grading activities;
- e. Storm water and allowable non-storm water discharge locations, including:
  - i. Locations of any storm drain inlets on the site and in the immediate vicinity of the site; and
  - ii. Locations where storm water or allowable non-storm water will be discharged to surface waters (including storm sewer systems and/or wetlands) on or near the site.
- f. Locations of all potential pollutant-generating activities.
- g. Locations of storm water control measures;
- h. Locations where tackifiers, polymers, flocculants, fertilizers, or other treatment chemicals will be used and stored.

**Construction Site Pollutants:** The SWPPP must include the following:

- a. A list and description of all the pollutant-generating activities on your site.
- b. For each pollutant-generating activity, an inventory of pollutants or pollutant constituents (e.g., sediment, fertilizers and/or pesticides, paints, solvents, fuels) associated with that activity,

which could be exposed to rainfall, or snowmelt, and could be discharged from your construction site. You must take into account where potential spills and leaks could occur that contribute pollutants to storm water discharges. You must also document any departures from the manufacturer's specifications for applying fertilizers containing nitrogen and phosphorus.

**Non-Storm water Discharges:** The SWPPP must also identify all sources of allowable non-storm water discharge. All non-storm water discharges must be managed or treated to prevent a discharge of pollutants.

**Buffer Documentation:** If you are required to comply with Part 2.1.2.a of the permit because a surface water is located within 50 feet of your project's earth disturbances, you must describe which compliance alternative you have selected for your site, and comply with any additional requirements to provide documentation in Part 2.1.2.a.

**Description of Storm Water Control Measures:**

- a. **Storm Water Control Measures to be Used During Construction Activity:** The SWPPP must describe all storm water control measures that are or will be installed and maintained at your site. For each storm water control measure, you must document:
  - i. Information on the type of storm water control measure to be installed and maintained, including design information;
  - ii. What specific sediment controls will be installed and made operational prior to conducting earth-disturbing activities in any given portion of your site;
  - iii. For exit points on your site, document stabilization techniques you will use and any additional controls that are planned to remove sediment prior to vehicle exit; and
  - iv. For projects at high altitudes that expect long seasons of heavy snow, you must document in your SWPPP when the snow season is expected so spring runoff controls can be installed before snowfall.
  - v. For linear projects, where you have determined that the use of perimeter controls in portions of the site is impracticable, document why you believe this to be the case.
- b. **Use of Treatment Chemicals:** If you plan to use cationic polymers and/or flocculants, you must have an approval letter from DWQ. Otherwise for treatment chemicals at your site you must include the following in your SWPPP:
  - i. A listing of all soil types that are expected to be exposed during construction and that will be discharged to locations where chemicals will be applied. Also include a listing of soil types expected to be found in fill material to be used in these same areas, to the extent you have this information prior to construction.
  - ii. A listing of all treatment chemicals to be used at the site, and why the selection of these chemicals is suited to the soil characteristics of your site;
  - iii. If you have been authorized by DWQ to use cationic treatment chemicals, include the specific controls and implementation procedures designed to ensure that your use of cationic treatment chemicals will not lead to a violation of water quality standards or a fish kill;

- iv. The dosage of all treatment chemicals you will use at the site or the methodology you will use to determine dosage;
  - v. Information from any applicable Material Safety Data Sheets (MSDS);
  - vi. Schematic drawings of any chemically-enhanced storm water controls or chemical treatment systems to be used for application of the treatment chemicals;
  - vii. A description of how chemicals will be stored.
  - viii. References to applicable state or local requirements affecting the use of treatment chemicals, and copies of applicable manufacturer's specifications regarding the use of your specific treatment chemicals and/or chemical treatment systems; and
  - ix. A description of the training that personnel who handle and apply chemicals have received prior to permit coverage, or will receive prior to use of the treatment chemicals at your site.
- c. **Stabilization Practices:** The SWPPP must describe the specific vegetative and/or non-vegetative practices that will be used, including:
- i. If you will be complying with the stabilization deadlines specified in Part 2.2.2 of the permit, you must indicate in your SWPPP the beginning and ending dates of the seasonally dry period and your site conditions; and
  - ii. For projects at high altitudes that expect long seasons of heavy snow, you must document in your SWPPP when the snow season is expected and so stabilization measures for spring runoff can be installed before snowfall.

**Pollution Prevention Procedures:**

- a. Spill Prevention and Response Procedures. The SWPPP must describe procedures that you will follow to prevent and respond to spills and leaks, including:
  - i. Procedures for expeditiously stopping, containing, and cleaning up spills, leaks, and other releases. Identify the name or position of the employee(s) responsible for detection and response of spills or leaks; and
  - ii. Procedures for notification of appropriate facility personnel, emergency response agencies, and regulatory agencies where a leak, spill, or other release containing a hazardous substance or oil in an amount equal to or in excess of a reportable quantity, occurs during a 24-hour period. Contact information must be in locations that are readily accessible and available.
- b. **Waste Management Procedures:** The SWPPP must describe procedures for how you will handle and dispose of all wastes generated at your site, including, but not limited to, clearing and demolition debris, sediment removed from the site, construction and domestic waste, hazardous or toxic waste, and sanitary waste.

**Procedures for Inspection, Maintenance, and Corrective Action:** The SWPPP must describe the procedures you will follow for maintaining your storm water control measures, conducting site inspections, and, where necessary, taking corrective actions. The following information must also be included in your SWPPP:

- a. Personnel responsible for conducting inspections;
- b. The inspection schedule you will be following,
- c. Any inspection or maintenance checklists or other forms that will be used.
- d. for each storm water control measure you must describe the strategy and schedule you plan to employ to maintain storm water control measures in effective operating condition for each precipitation event or you will be expected to replace, repair, and/or maintain problems found with storm water control measures immediately after each inspection.

**Staff Training:** The SWPPP must include documentation that the required personnel were trained in accordance with Part 6 of the permit, and all other relevant training be documented (including training in Section 2 for projects that use treatment chemicals).

**UIC Class 5 Injection Wells:**

- a. **Utah Water Quality Act Underground Injection Control (UIC) Program Requirements for Certain Subsurface Storm Water Controls.** If you are using any of the following storm water controls at your site, as they are described below, you must document any contact you have had with DWQ for implementing the requirements for underground injection wells in the Safe Drinking Water Act and DEQ's implementing regulations at UAC R317-7. In addition, there may be local requirements related to such structures. Such controls (below) would generally be considered Class V UIC wells and all UIC Class V wells must be reported to DWQ for an inventory:
  - i. French drains (if storm water is directed to any bored, drilled, driven shaft or dug hole that is deeper than its widest surface dimension, or has a subsurface fluid distribution system);
  - ii. Commercially manufactured pre-cast or pre-built proprietary subsurface detention vaults, chambers, or other devices designed to capture and infiltrate storm water flow; and
  - iii. Drywells, seepage pits, or improved sinkholes (if storm water is directed to any bored, drilled, driven shaft or dug hole that is deeper than its widest surface dimension, or has a subsurface fluid distribution system).

**List of Impaired Waters that Receive a Discharge:**

- a. A list of all impaired waters to which you discharge;
- b. The pollutant(s) for which the surface water is impaired; and
- c. Whether a Total Maximum Daily Load (TMDL) has been approved or established for the waters to which you discharge.

**SWPPP Certification.** The owner/operator must sign and date your SWPPP.

**Also Included in the SWPPP:** Once you have completed the submission of your on-line Notice of Intent (NOI) (or paper submission for some), you must include the following documents as part of your SWPPP:

- a. A copy of your NOI,

- b. A copy of this permit (an electronic copy easily available to the storm water team is also acceptable).

---

## 5 - LONG-TERM STORM WATER MANAGEMENT IN NEW DEVELOPMENT AND REDEVELOPMENT (POST CONSTRUCTION BMPS)

Best management practices if currently in place must continue to be implemented, and new practices must be implemented as part of a long-term plan to keep storm water free from pollutants. Low impact development (LID) measures shall be required on all development work and city projects unless it can be demonstrated that there are special conditions that make them not reasonably feasible to implement. Enforcement is also a key component of implementation of Post-Construction BMPs.

It is the responsibility of the developer or designer on city projects to propose the LID measures that will be best for the site and that meet minimum City and State standards, and to provide supporting documentation showing the effectiveness of such measures. Having established LID measures that the city accepts outlined in the proposed technical manual will ease the design and review process. The LID method must be evaluated based on whether it meets the purpose and minimum criteria of the City and State standards, in consideration of the entire proposed system: retaining the 90<sup>th</sup> percentile storm, minimizing runoff, reduction and elimination of target pollutants to acceptable levels, maintenance requirements and enforceability of maintenance, aesthetics, and capacity.

### **General Post Construction Storm Water and LID Approach Recommendations**

The recommended general practice in Santaquin is to provide oil-water and trash separators, and coarse-sediment removal devices such as sand traps or hydrodynamic separators, followed by detention, retention or infiltration basins. Oil/water and trash separators may be located at inlets or in-line prior to entry into the basin. In addition, onsite LID practices that reduce or slow runoff and minimize transfer of pollutants shall be required such as porous pavements, swales, minimizing hard surfaces, or other practices. Where such practices do not satisfactorily eliminate biomass, nutrients, sediment, or other pollutants, other measures shall be required. The developer or designer must propose their solutions and provide supporting documentation, which the city shall accept or reject based on its meeting the minimum criteria.

### **Treatment Design Storm**

A Treatment Design Storm must be designated which BMP measures must be designed to handle and still meet their stated pollutant removal capabilities. The effectiveness of the BMP may decrease with increasing flows beyond this limit, but every feasible measure must be employed to retain oils, trash, and other floating debris, and to not disturb previously collected sediment during these high flow events. A 2-year 2-hour storm is recommended as the Treatment Design Storm.

### **Storm Water Technical Manual**

It is recommended that a Storm Water Technical Manual that addresses both storm drain design standards and pollution and LID BMPs be developed. Enforcement of these measures shall be outlined

in the Standard Operating Plan. The following is an example of a summary schedule of activities that should be performed as part of fulfilling an MS4 permit:

**Table 7. Long-Term Stormwater Management Policy Proposed Schedule**

<b>Best Management Practice (BMP)</b>	<b>Measureable Goal</b>	<b>Implementation Schedule</b>
<b>Ordinance to Mandate Controls of Quality, Quantity of Post Construction Storm Water Runoff, LID Practices</b>	Review Ordinance Update Ordinance	Annually As needed
<b>Develop Enforcement Strategy</b>	Develop SOP Review SOP Update SOP	12 Months from MS4 Inclusion Annually As needed
<b>Review and Update Development Code</b>	Review and update Development Code	As needed
<b>Retrofit Program</b>	Review Program Update Program	Annually As needed
<b>Hydrologic Method</b>	Review Method Update Method	Annually As needed
<b>Site Plan Review Procedures</b>	Review Update Site Plan Review Procedures	Annually As needed
<b>Storm Water Technical Manual (Includes required Design, Pollution Control, and LID Practices)</b>	Review Manual Update Manual	Annually As needed
<b>Inspection and Enforcement</b>	Develop SOP	12 Months from MS4 Inclusion

Best Management Practice (BMP)	Measureable Goal	Implementation Schedule
	Review SOP	Annually
	Update SOP	As needed
	Document Inspection and Enforcement	Ongoing
<b>City Staff Education</b>	Yearly Training	Annually
<b>Maintain Inventory</b>	Update Inventory	Annually

---

#### POST CONSTRUCTION BMPs AND LOW IMPACT DEVELOPMENT

Typical post-construction BMPs are listed in this section. The benefits of each and recommendations specific to Santaquin are included with each description. This is not an all-inclusive list, and more measures should be identified as part of developing a Storm Water Technical Manual for the City.

Benefits are identified as “Pollutant Control” or “LID” (Low Impact Development). Pollutant control measures decrease or eliminate the pollutants that would otherwise be carried by the storm water runoff to receiving waters.

Low impact development is an approach to storm water management that maintains the site’s natural hydrology as the landscape is developed. The result is infiltration, evaporation, or use of storm water. The goal of low impact development is to protect water quality and associated aquatic habitat. Typical LID practices include bioretention facilities, rain gardens, vegetated rooftops, rain barrels, and permeable pavements (EPA, 2016).

Implementation of Low Impact Development (LID) practices shall be required wherever feasible by development and for city facilities. Where not implemented, it must be documented why LID methods are not feasible for a given project. LID practices should be incorporated into the city’s development standards.

Long-term maintenance costs and requirements must be considered when implementing LID practices to ensure a viable overall approach.

Hydrologic and hydraulic analysis must be of sufficient detail and nature to account for the storage effects and infiltration rates of such systems, as applicable.

**Biofilters (Pollutant Control, LID):** Biofilter is a generic description for bioswales, vegetated filter strips, rain gardens, or other structures that use a filtration media to capture storm water pollutants. The

pollutants are decomposed by a biomass such as plants, a tree or a specially designed bio filter media. These systems are typically connected to a storm drain system.

Commercially available structures are also available that take water from an inlet structure or other source and then direct it through the roots of the plants contained within the structure. These structures can reduce the footprint required to implement effective biofiltration.

Aesthetics and maintenance are major concerns with biofilters. This method of pollutant removal is recommended only where proper maintenance can be assured, where the aesthetics are preferred, or where no other satisfactory means of pollutant control is available or effective.

#### *Rain Gardens/Bioretenention Design*

A rain garden is a planted depression or similar feature that allows rainwater runoff from impervious urban areas like roofs, driveways, walkways, parking lots, and compacted lawn areas the opportunity to infiltrate into the soil.

Rain gardens are an LID tool that can be used in new or in established developments. Rain gardens can be constructed in commercial and residential sites. The garden may be located near a street or parking lot in a shallow depression where runoff can be diverted into it. Native perennial plants are recommended in raingardens with a barrier to reduce weeds. Nutrients in the storm runoff are reduced as plants or other growing media make use of them to grow.

Rain gardens can be constructed to allow infiltration or to be self-contained. Where complete infiltration is not desired or is not feasible due to existing soil conditions, an underdrain may be installed to convey excess water to a storm drain system.

Installation costs are generally \$10-\$15/square foot. Long-term maintenance includes watering for the first one to two years, applying mulch until groundcover establishes, removing dead plant material, weeding, sediment removal, and replanting as necessary. Data for long-term maintenance costs is not available as the cost varies greatly by region and with the type of rain garden installed.

Studies underway at Utah State University have identified common reed and sedges are the optimal plant for use in northern Utah to remove nutrients, metals, and other pollutants (Dupont and McLean), but it must be harvested and disposed of elsewhere at regular intervals to prevent concentration of pollutants in the soil in the biofilters. Mulching and leaving in place does not address this. Whether such concentrations are critical depends on the contact with groundwater, and is still under study.

Biofilters must be shallow and water must pool or move slowly through the system or the pollutant removal is ineffective.

A curb cut is one means of directing flow into bioswales where changes in elevation are limited.

**Screen or Medium Filters:** These manufactured storm drain treatment systems use screens or filter media to remove contaminants. They can treat a significant amount of water, handle higher



concentrations of pollutants, or critical pollutants, but can be costly, and require regular changes or cleaning of the screens or filter media. These will be considered only in the most critical applications.

**Detention/Retention Facilities (Pollutant Control, LID):** Detention basins are used to attenuate peak flow rates of a runoff hydrograph. They also can be designed to allow sediments and other debris and contaminants to settle out by reducing water velocity or holding the water until it infiltrates and evaporates. Retention basins have no outlet and water is removed by infiltration, or evaporation. Retention basins still function as a BMP the same way a detention basin does. Detention and retention basins can be combined with biofiltration systems.

**Infiltration Basins (Pollutant Control, LID):** An infiltration basin is essentially a detention basin that is constructed such that storm water can exit the basin by means of infiltration into the surrounding ground. These include underground pipe and chamber systems. These systems can reduce pollutants by settling out or filtering materials, and any pollutants that may be bound to those materials, reducing concentrations of nutrients, metals and other pollutants, but usually not eliminating them, unless there is no outlet. If there is no outlet, the implementation of mitigation measures or monitoring shall be considered for concentration of pollutants within the basin and subsoil. Oil/water separators and settling chambers shall be used in combination with these systems. Cleaning, maintenance and overflow during flood level events must be addressed.

Basins with no outlet or highly restricted outlets can be effective at eliminating pollutants, but there is some risk of concentrating pollutants or introduction of pollutants to groundwater that must be considered. Utilization of a biofilter or other pollutant removal measures within or upstream from a basin that is sized to handle the Treatment Design Storm is one way to address this.

Underground injection wells are included in this category, but water quality and applicable regulations would have to be addressed.

**Permeable Pavements (LID):** Permeable pavement may consist of pavers, porous concrete, or asphalt. It allows rainwater to infiltrate through it rather than running off to a storm drain system. Pervious pavement is best for parking lots, sidewalks and road shoulders. There are several types of pervious pavement including pervious concrete pavement, pervious pavers, porous asphalt, and proprietary grid/cell elements. Porous asphalt has been used effectively in limited applications in Utah despite freezing, but it requires effective drainage systems underneath. Due to the high elevation and cold temperatures in Santaquin, permeable pavement is not recommended as a viable LID practice.

**Oil-Water and Hydrodynamic Separators:** Separators may consist of a water quality hood such as a snout or a concrete vault with baffles and/or filters in it to collect sediment, debris, and oils while allowing the clean water to pass through. These systems can be installed relatively efficiently, but do not remove 100% of contaminants. Only the pollutants that are bound to the settled materials or that float are removed. Other suspended or soluble pollutants may bypass the structure. They can be effective initial treatment measures, and if pollutant concentrations are low enough, can be sufficient to meet TMDL requirements. They are recommended for use in Santaquin City where basins or other measures are not already providing the same benefit, or where system maintenance of a facility may be an issue if

pollutants are allowed to enter. Manufacturers provide effectiveness and installation recommendations. Typically, a treatment design storm must be selected, above which some bypass of flows is permitted.

**Outlet Protection/Energy Dissipation Devices:** Outlet protection reduces or eliminates soil erosion thereby preventing the migration of soil to downstream channels. Outlet protection is required at all open discharge points, unless approved otherwise based on scour analysis.

**Slope Protection:** Slope protection ensures slopes will be stable during and after construction. The primary means of stabilization of a slope is establishing permanent vegetation, but may also consist of temporary or permanent rock, mulch, erosion control blankets, check dams, diversion dikes, or other means of protection.

**Vegetated Rooftops:** Vegetated Rooftops or green roofs reduce runoff by holding on to and slowing down water that would flow into storm drain systems. Green roofs typically consist of a lightweight soil media, a drainage layer and an impermeable membrane to protect the building structure. Specific plant varieties that can withstand high temperatures and dry conditions must be selected for this LID practice. This LID practice is generally used on a case-by-case basis in urban settings, and is not recommended for general practice in Santaquin due to high maintenance requirements associated with Utah's climate.

**Rain Barrels/Cisterns:** Previously prohibited, rainwater harvesting has been legal in Utah since 2010. The total volume of rainwater harvesting containers cannot exceed 2,500 gallons per parcel. Containers may be placed below or above ground provided they meet building codes. The water can be used for watering a garden or landscaping or even for cleaning items around your home. Parcel owners need to register their rainwater harvesting system if they have more than two covered containers or any container has a maximum storage volume greater than 100 gallons. (USU Extension, 2016)

It is not recommended to enforce this practice on a citywide basis as a development standard/requirement, but individuals and developers may propose such for consideration if they desire.

**BIO-Swales/Park strips/Grassed Swales:** Bio-swales are landscape elements designed to convey storm runoff and concentrate or remove island pollution from surface runoff water. For best results, existing natural swales should be used whenever possible. Park strips may serve as a vegetative buffer between paved areas and water bodies. Storm runoff flows over the park strip, where sediment and pollutants may settle out prior to entering a stream or other channel.

Grassed swales (park strips) are often an attractive BMP solution because they take advantage of already planned park strips. It should be noted that studies have shown grassed swales have a moderate ability to remove pollutants from storm water. Unless the underlying soils allow significant infiltration, soluble pollutants will not be removed. Their main advantage is in the degree of velocity reduction, detention, infiltration, and reduction of hard surface runoff.

**Infiltration Trench:** Trenches full of drainage and/or filtration materials that infiltrate water and may also direct it into drainage pipes within the trench. These can often be used in the construction phase as

well to control surface and groundwater. The surface can form pervious gravel walking paths, and they may be used in combination with grassed swales and similar features. It must be demonstrated how maintenance and pollutants will be handled, and the infiltration rate must be considered.

## 6 - POLLUTION PREVENTION AND GOOD HOUSEKEEPING FOR MUNICIPAL OPERATIONS

Good housekeeping BMPs control pollutant discharges once developments are complete and at municipal facilities. The intention is to keep pollutants from coming in contact with storm water and keeping pollutants from being dumped or poured into storm drains. Table 8 below lists the practices recommended to be in place in order to comply with MS4 requirements.

**Table 8. Good Housekeeping for Municipal Operation Proposed Schedule**

<b>Best Management Practice (BMP)</b>	<b>Description</b>	<b>Measureable Goal</b>	<b>Implementation Schedule</b>
<b>Inventory</b>	Prepare inventory of all city owned and operated facilities which discharge or convey any runoff or pollutants	Review and Update	Annually
<b>Assessment</b>	Assess all items in inventory for potential for discharge of target pollutants	Review and Update	Annually
<b>High Priority Designation</b>	Assign high priority facilities to be addressed	Review and Update	Annually
<b>Develop Facility Specific SOP's</b>	Develop site specific SOP's for each high priority site.	Review and Update SOP's	Annually
<b>Floor Drain Inventory</b>	Inventory all floor drains in city facilities which discharge to surface or to storm drains	Develop Inventory Update Inventory	24 Months from MS4 Inclusion Annually
<b>Storm Drain Inventory and Map</b>	Develop Inventory and map of all storm drain facilities	Develop Inventory Update Inventory	6 Months from MS4 Inclusion Annually

Best Management Practice (BMP)	Description	Measureable Goal	Implementation Schedule
<b>Inspections</b>	Perform weekly visual and quarterly comprehensive inspections of high priority facilities.	Perform and Document Required Inspections	Quarterly and after large storm events
<b>Flood Management Control Structures</b>	Develop and implement process to assess the water quality impacts in the design of all new flood management structural controls.	Review Process for New Facilities Evaluate Existing Facilities	Annual Update 20% a year for five years, as needed after
<b>City Staff Education</b>	Train staff involved with primary construction, operation, or maintenance job functions that are likely to impact storm water quality	Yearly Training	Annually

Minimum Good Housekeeping BMPs that should be implemented are described below. A more complete list should be developed as part of the process of developing the Storm Water Management Plan and site specific SOPs.

**Pavement Cleaning:** Keeping parking areas free from sediment and debris ensure this will not be washed downstream to the storm drain system.

**Litter Control:** Litter is a common storm water pollutant. Provide adequate trash bins and pick up litter and other waste from inlets.

**Waste Disposal:** Inspection of dumpsters, covering dumpsters or waste containers ensure that refuse does not become airborne, or removed by animals, etc.

**Materials Storage:** Proper storage of hazardous materials such as grease, paints, metals etc. reduces the potential for spills.

**Training:** Training City employees that deal with storm water pollution prevention regularly, ensures proper methods and practices are understood and implemented.

**Equipment/Vehicle Cleaning:** Vehicles must be maintained regularly and checked for leaks. Use a pan to collect spills during maintenance activities. Washing vehicles in a designated area away from storm drain inlets prevents chemicals from entering the storm drain system.

**Spill Prevention and Control Plan:** Having a plan in place helps staff members know what to do should a spill occur. The plan will help to prevent a spill and minimize the effects of the spill.

## MAINTENANCE GUIDELINES

Maintenance of a storm drain system is vital to the success and function of the system. Often, a problem that requires maintenance is not known until a large storm event occurs which causes storm water backup or inundation. In order to keep the storm drain system functioning properly and avoid maintenance-related flooding issues, the following guidance should be followed.

### INSPECTION AND CLEANING SCHEDULE

The following schedule should be used for inspecting and maintaining the City storm drain infrastructure.

**Table 9. Inspection and Cleaning Schedule**

Task	Frequency
Inspect and clean as needed all storm drain inlet grates.	At least once per year
Inspect and clean as needed all storm drain inlets (interior).	At least once every other year (50% of system inspected and cleaned each year)
Inspect and clean as needed all storm drain inlets in known problem areas.	At least once per year
Inspect and clean as needed all storm drain pipes. May include camera inspection as needed.	At least once every 5 years (20% of system inspected and cleaned each year)
Inspect and clean as needed all storm drain pipes in problem areas.	At least once per year
Inspect and clean as needed all infiltration galleries.	At least once per year
Inspect and clean as needed all detention and retention basins.	At least once per year
Street sweeping and gutter cleaning	At least once per year

Storm drain inlet grates must be kept free of debris such as trash, leaves and sediment. This can be accomplished through street sweeping and otherwise physically removing the debris. Inlets that contain a "Snout" or other water quality hood must be inspected to ensure there is no blockage. The floatable

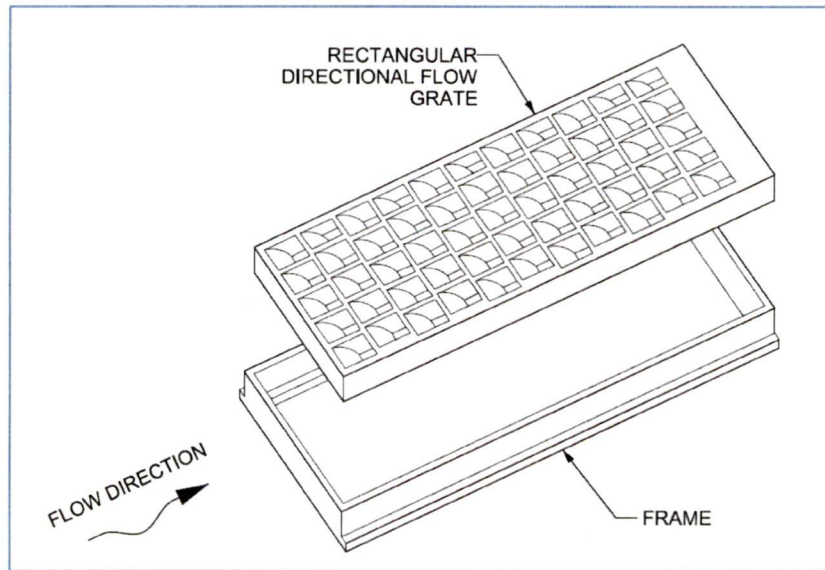

**Figure 3. Direction Flow Grate**

Although not a deficiency which requires capital improvements, correcting grate orientation for the grates on the hillside developments will greatly improve the function of the existing storm drain systems. During a field investigation of one street, 8 out of 20 grate inlets were positioned backwards. This should be corrected as soon as reasonably possible. Figure 4 is a photograph of one such grate.



**Figure 4. Incorrectly Oriented Directional Grate**

Sumps or infiltration galleries shall also be inspected to ensure they are free of debris. Any sumps that are known to have infiltration problems should be inspected each spring and after large storm events to determine if their functionality has decreased.

Pipe inspection should occur on an every-five-year basis or as determined to be required due to conveyance or plugging problems. Pipes with a very mild slope may also require more attention as they are prone to sedimentation. Even though the pipe may have a self-cleansing velocity while conveying peak flows, as the flows recede and slow down, sediment can be deposited in the pipe.

Retention basins must be inspected and maintained annually. The inspection must include determining whether there is any deterioration of the basin, recording the high water mark (if available), and determining whether the basin has overflowed. Maintenance measures for these basins include removal of trash and debris, mowing sodded basins, and generally ensuring the available volume within the basin has not been compromised.

#### HIGH PRIORITY AREAS

High priority/problem areas have been identified as areas that frequently have drainage problems or maintenance issues. These areas include the vicinity of 330 West and 650 North, and the southeast bench from 400 East to 900 East. Other areas within the City have drainage problems, but do not have drainage infrastructure. Because there is not infrastructure to inspect in these areas, they are not listed as high priority in this document.

#### POST-FIRE WATERSHED MITIGATION

Post-fire mitigation measures in watersheds are usually handled by state and federal agencies rather than the city, but inclusion of the following considerations in the case of a wildfire is suggested:

- Rehabilitation of any burned areas should emphasize tackified mulch and seed cat-tracked into the soil on slopes. Using log erosion control barriers can help prevent erosion as the vegetation is becoming established.
- Maintenance of all control measures, including LEB's (log erosion barriers), by removal of collected sediment is crucial to proper function.
- Most sediment comes from channel erosion; reducing runoff on slopes is a key goal to minimize large flows and debris from burned conditions.

#### MAINTENANCE RECORD KEEPING

Inspections and record keeping should be done through a web based GIS map or other similar program. The programs should be set to send reminders of inspection times to maintenance staff. Inspection and cleaning logs are input into the system via a tablet or cell phone and should include information regarding the inspection findings, work completed, if any, and applicable photographs. An example of a web-based GIS inspection map for sewer inspections is shown in Figure 5.

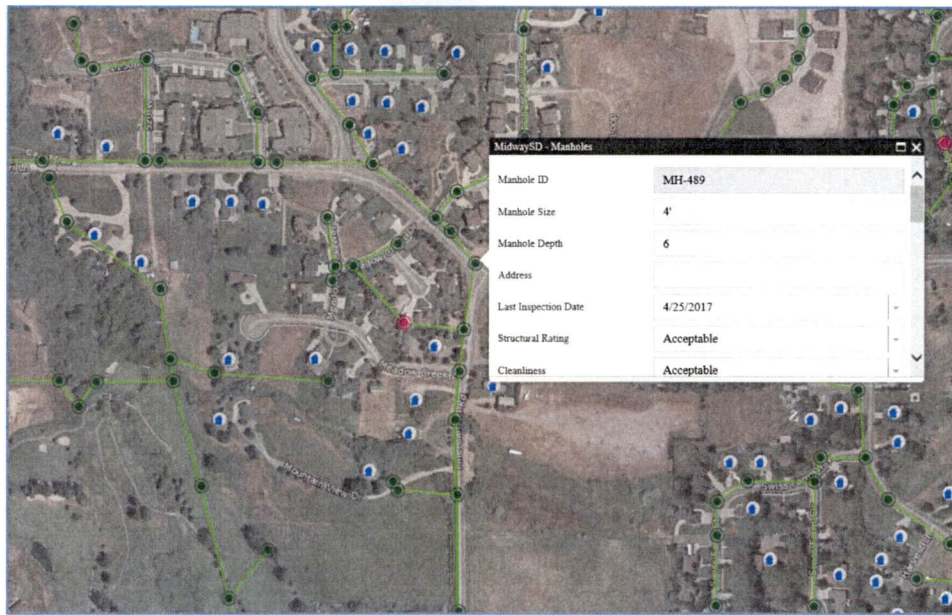

Figure 5. Inspection Program Interface

## DRAINAGE POLICIES

Drainage policies listed in this master plan document become part of the code as the document is adopted by ordinance.

## GENERAL REQUIREMENTS

The design of the storm water management system must be consistent with general and specific concerns, values, and standards of the municipal master plan and applicable county, regional, and state storm drainage control programs. Design must be based on environmentally sound site planning and engineering techniques.

The best available technology shall be used to minimize off-site storm water runoff, increase site infiltration, encourage natural infiltration and filtration functions, simulate natural drainage systems, and minimize off site discharge of pollutants to ground and surface water. Best available technology may include measures such as retention basins, recharge trenches, piping, contour terraces, and swales.

The following general requirements apply to all new developments within Santaquin City:

- All new developments in the city shall conform to the specifications of this master plan, as adopted by ordinance, and be compatible with basin wide master drainage plans. All storm water management systems must be approved by the city engineer.



- All storm water calculations and designs shall be stamped and signed by a qualified professional engineer using currently accepted civil engineering practices, applicable safety standards and city approved design standards. Calculations and designs shall be based on a field investigation taking into consideration the development's off site contributing and receiving drainage areas.
- All new developments are encouraged to utilize ground water recharge methods when designing a storm water management system.
- All storm water management systems shall provide on-site retention for a 25-year storm event, and control of the 100-year event, as described in the adopted Storm Drain Master Plan.
- New developments shall not cause a natural drainage channel to be filled in, obstructed, or diverted. When proposing modifications to a natural drainage channel, a development drainage control plan shall be submitted for approval by the city engineer.
- The point where the natural drainage channel enters and leaves the property shall not be changed without approval of the city engineer.
- Storm drain improvements shall be considered to be permanent and shall be designed and constructed accordingly. Storm drain improvements shall be designed for trouble free maintenance.
- All lots shall be graded with a minimum slope of five percent (5%) away from any building for at least ten feet (10') from the building, or as specified in the most recent adopted building code.
- All storm water systems shall be separate and independent from sanitary sewer systems.
- Maintenance easements shall be provided for storm water facilities where such facilities are located outside of the public right of way. The size of the easement shall be dictated by working needs. In general, the easement shall be twenty feet (20') in width for one utility and five (5) additional feet, if practicable, for each additional utility located in the same easement.
- All storm water systems shall be designed for erosion control; the velocity must be estimated and compared to the allowable velocity for the material on which the water is flowing. (Ord. 05-01-2003, 5-7-2003, eff. 5-8-2003)

## DESIGN REQUIREMENTS

The following design standards shall apply to the design of all storm water management improvements whether public or private, whether new development or "off-site", whether above or below design discharge points, whether within a floodplain or not, or within a natural channel or not:

Hydrology: Estimation of peak storm water runoff rates shall be performed using the Rational method or a hydrograph method analysis accepted by the city engineer.

- Storm Frequency:
  - All storm water management systems shall provide collection and on-site retention of a 25-year storm event as provided in Santaquin City Code 11-12-3.
  - Control the flooding hazard of a 100-year storm event.
  - In cases in which a proposed storm drain system would be adequate for the 25-year flows but 100-year flows could potentially cause property damage or loss of life, or exceed specified limits on spread or depth, the 100-year storm shall be used as the design storm.

- Coordination of street grades with lot drainage; positive slope away from all sides of the house shall be provided.
- Street Flooding Evaluation: The following criteria shall be used to determine at what threshold street flooding shall be considered unacceptable:
  - For the 25-year storm event:
    - Allowable flows in streets shall be limited to the height of the curb.
    - Flow may extend into half of lane for collector road; arterial roads must have the equivalent of one lane open in each direction.
    - Storm water runoff must be intercepted into storm drains as soon as is practically possible.
  - For the 100-year storm event:
    - Street flooding is acceptable as long as no property damage occurs.
    - Street flooding must be contained within the road right of way.
    - Street flooding must at no time exceed twelve inches (12") in depth.
    - Street flooding must not exceed two (2) hours in duration.
- Flow Across Intersections: A critical situation exists where a street on a grade intersects with another street, especially a collector road. Storm drain inlets must be installed near the curb return to intercept all runoff and prevent it from flowing across the road. Cross gutters are not permitted except in extenuating circumstances, and can only be permitted by the City Engineer within limited criteria. Even when the flow on the grade is severely limited, great care must be taken to ensure that inlets will intercept virtually all the flow from a 25-year storm event.
- Storm Water Retention: Storm water retention shall be designed to reduce peak runoff rates, aid in the replenishment of the ground water supply, provide an attenuation mechanism for storm water treatment, lessen the possibility of downstream flooding, stream erosion, and sedimentation, and can be used in the development of upstream areas to avoid increasing the runoff peaks which impact existing downstream facilities. Storm water storage shall be provided by either infiltration galleries or retention basins.
- Infiltration Galleries: Under favorable conditions of deep, permeable subsoil, runoff may be discharged into infiltration galleries backfilled with gravels chosen and placed in accordance with sound graded filter principles. As long as the system does not become clogged by sediment, it will accomplish the dual purpose of disposing of at least part of the storm water and of recharging ground water storage. Following are some infiltration gallery design requirements:
  - All new developments requiring galleries must locate them within the boundaries of the development.
  - A percolation test must be performed within one hundred feet (100') of any proposed galleries location and shall be witnessed by the city engineer or their designee.
  - When calculating the percolation area of an infiltration gallery, the area of the sides of the galleries is to be omitted and only the bottom may be considered. The City Engineer may waive this if in his opinion percolation calculations satisfactorily account for the time required to fill the infiltration gallery.
- Retention Basins:
  - Retention basins are intended to temporarily store runoff and to provide ground water infiltration. They shall be designed to fully contain runoff from a 25-year storm event, or the 100-year event if there is no other means of controlling that event.
  - Low Impact Development (LID) measures installed upstream of a retention basin which reduce runoff may be used as justification to reduce the volume required in retention basins, unless the capacity of such runoff reduction measures can reasonably be

expected to fail without proper maintenance. In such cases, no volume reduction shall be accounted for when determining the overall size of retention systems.

- Proposed reductions in volume due to LID measures must be calculated, stamped and signed by the design engineer, and approved by the City Engineer.
- Retention facilities must be located as far horizontally from surface water and as far vertically from ground water as is practicable. Retention facilities shall not intercept the post development ground water table, where practicable.
- If a retention basin is intended for access by the public, the maximum depth of the basin, from the invert to the top of the embankment, shall be three feet (3'), including one foot (1') of freeboard. All retention basins intended for public access shall be sodded or otherwise landscaped as approved by the city engineer.
- If a retention basin is not intended for public access, the basin depth may exceed three feet (3') but shall not exceed fifteen feet (15'), including one foot (1') of freeboard. Such retention basins shall not be located near streets and shall be out of public view. All retention basins not intended for public access must be enclosed by a six foot (6') high fence having at least on 10-foot wide access gate. The fence must be placed on the outer edge of the embankment, providing maintenance access to the entire perimeter of the basin.
- When a basin is deeper than 5 feet (5') the side slopes must be stepped at 5 foot (5') intervals to allow easier evacuation by anyone who might be in the pond. Alternative approaches must be approved by the City Engineer.
- Aboveground basins, or basins that rely on a berm on one side are not permitted unless otherwise approved by the City Engineer. Berms will be constructed to industry and applicable State of Utah Dam Safety Standards.
- Designs for embankments or water retaining berms must be stamped and signed by qualified engineers with experience in dam hydrology, hydraulics, and geotechnical concerns.
- The minimum top widths of all embankments shall be ten feet (10').
- Retention basins must be designed to have at least one foot (1') of freeboard.
- Side slopes of retention basins shall have a maximum slope of four to one (4:1) (4 horizontal, 1 vertical) unless approved by the city engineer.
- Retention basins shall be designed to provide maintenance access around the entire embankment.

The following suggestions are recommended as potential amendments or modifications to the code. They are made in light of the unique circumstance of having no available outfall and the potential impacts on flooding this causes.

- The minimum slope for grading lots shall be 6 inches of fall within the first 10 feet from a building (5%) per building code.
- Comingling of storm water and irrigation systems shall be prohibited as much as is practicable.
- A 30" high back curb and gutter may be considered in areas of town that are very flat. The current standard is a 24-inch total width.
- Drainage design for cul-de-sacs must be for the 100-year event minimum.

- All inlets must be analyzed for bypass. This is already a requirement but calculations must be included in the drainage report for new developments and be examined carefully during the review process. Many inlets on steep roads experience inlet bypass. Even though the sump or infiltration gallery may have sufficient volume, the water flows by the inlet, thus not utilizing the full available volume.

## EXISTING SYSTEM

The City's existing system consists of pipes open channels, retention basins, catch basins, outfalls, junction manholes, etc. Much of the system has been installed in the last 20-25 years and is in good condition. The typical design life of a storm water facility is between 30 and 80 years. To determine needed improvements, the most up-do-date information available has been used in the preparation of this report. GIS data has been supplied by Santaquin City. Mapping of existing storm drain structures and pipes within the city has been completed as part of the City mapping and GIS program. Maintaining a complete storm drain system inventory is an ongoing process. Doing so enables the City to schedule maintenance, repair, and replacement of storm drain infrastructure. It also enables more detailed planning and modeling of the storm drain system.

Maps of the existing storm drain system as well as the Summit Creek Irrigation system are shown on the following six pages.

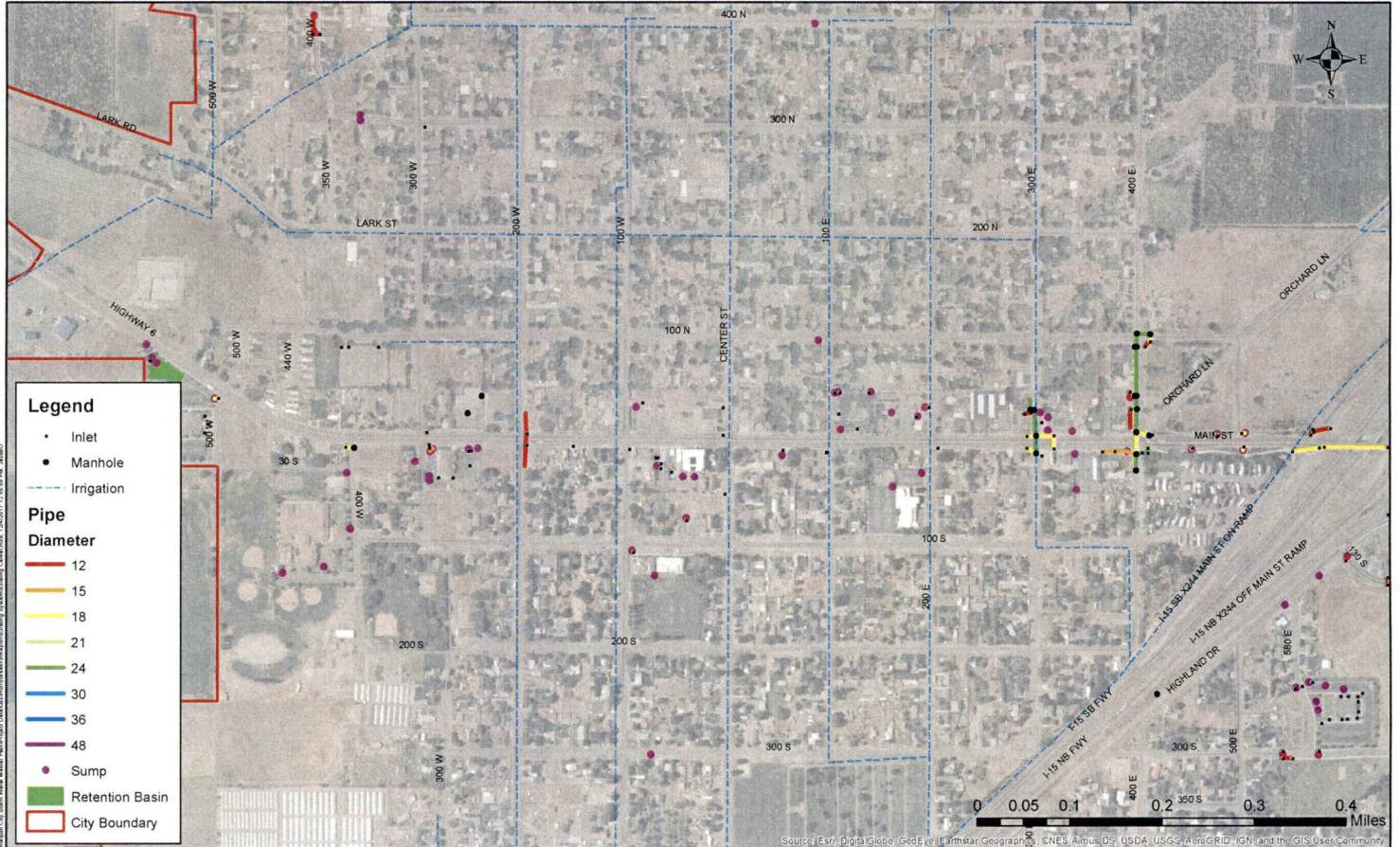

© 2017 Esri, DigitalGlobe, GeoEye, Earthstar Geographics, CNES/Airbus DS, USDA, USGS, AeroGRID, IGN, and the GIS User Community



Existing System  
Center

12/4/2017  
Figure 1

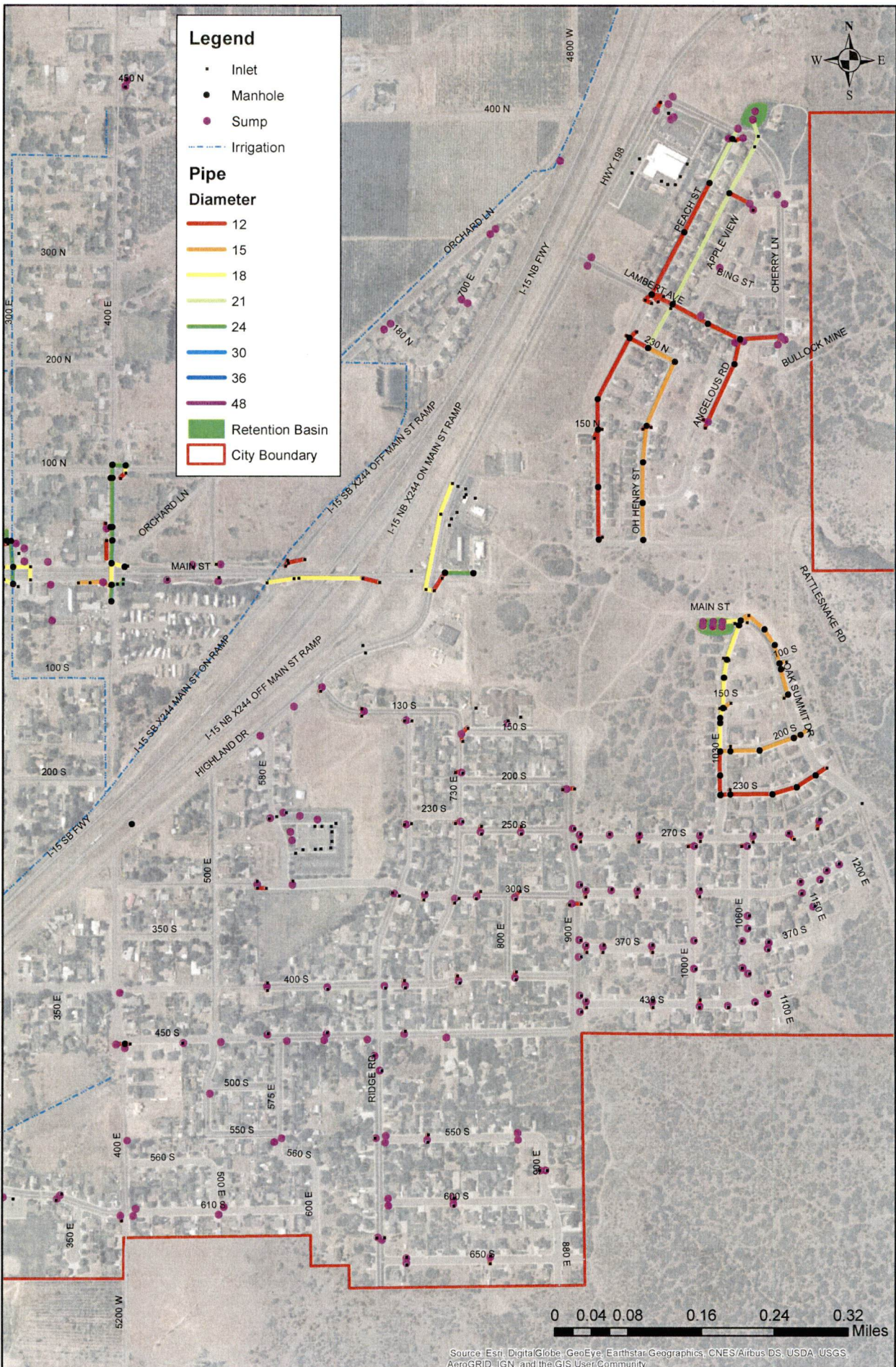

**Legend**

- Inlet
- Manhole
- Sump
- - - Irrigation

**Pipe Diameter**

- 12
- 15
- 18
- 21
- 24
- 30
- 36
- 48

- Retention Basin
- City Boundary

© 2017 ESRI, Inc. All rights reserved. Esri, the Esri logo, ArcGIS, the ArcGIS logo, and the ArcGIS logo are either registered trademarks or trademarks of Esri Inc. in the United States and/or other countries.

0 0.04 0.08 0.16 0.24 0.32 Miles

Source: Esri, DigitalGlobe, GeoEye, Earthstar Geographics, CNES/Airbus DS, USDA, USGS, AeroGRID, IGN, and the GIS User Community



Existing System  
East

DATE	12/4/2017
DRAWN	
Figure 1	

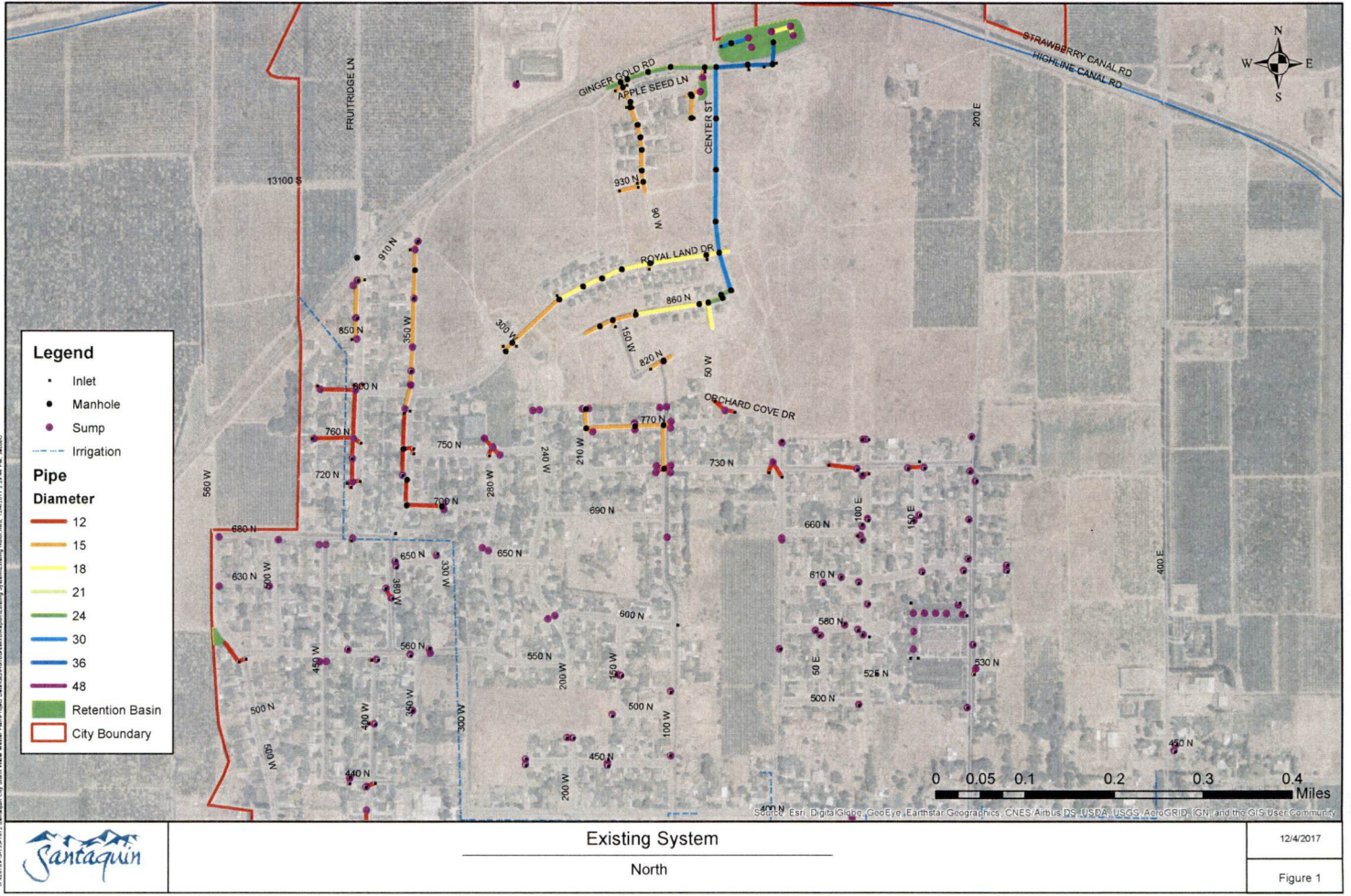

© 2016 ESRI. All rights reserved. ESRI, the ESRI logo, ArcGIS, the ArcGIS logo, and the ArcGIS User Community logo are either registered trademarks or trademarks of ESRI in the United States and/or other countries. All other marks contained herein are the property of their respective owners.



Existing System

North

12/4/2017

Figure 1



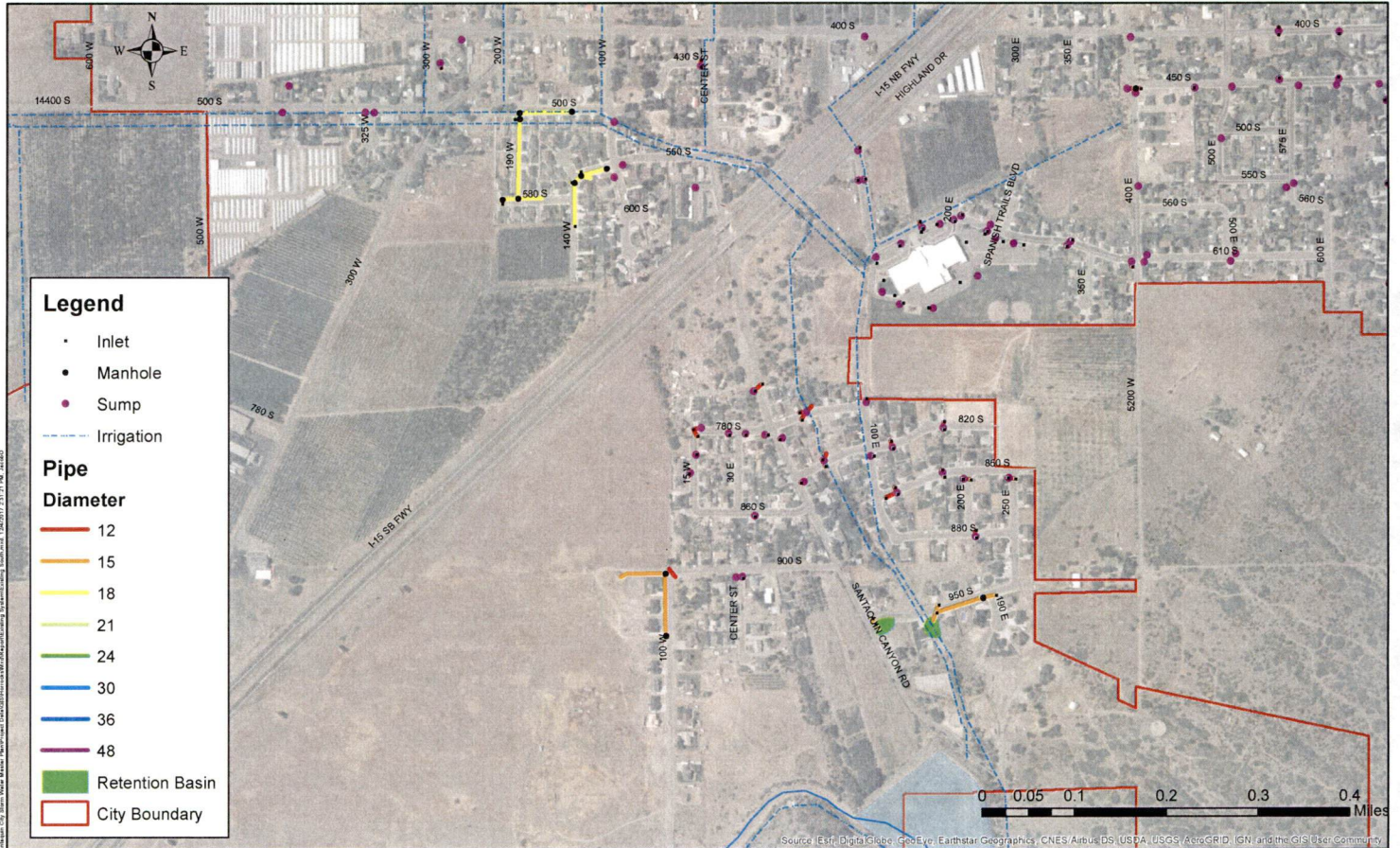

0:00:00.000 135.1512 12/4/2017 12:28:00 PM Santaquin, UT 84055



Existing System

South

12/4/2017

Figure 1



**Legend**

- Inlet
- Manhole
- Sump
- Irrigation

**Pipe Diameter**

- 12
- 15
- 18
- 21
- 24
- 30
- 36
- 48

Retention Basin

City Boundary

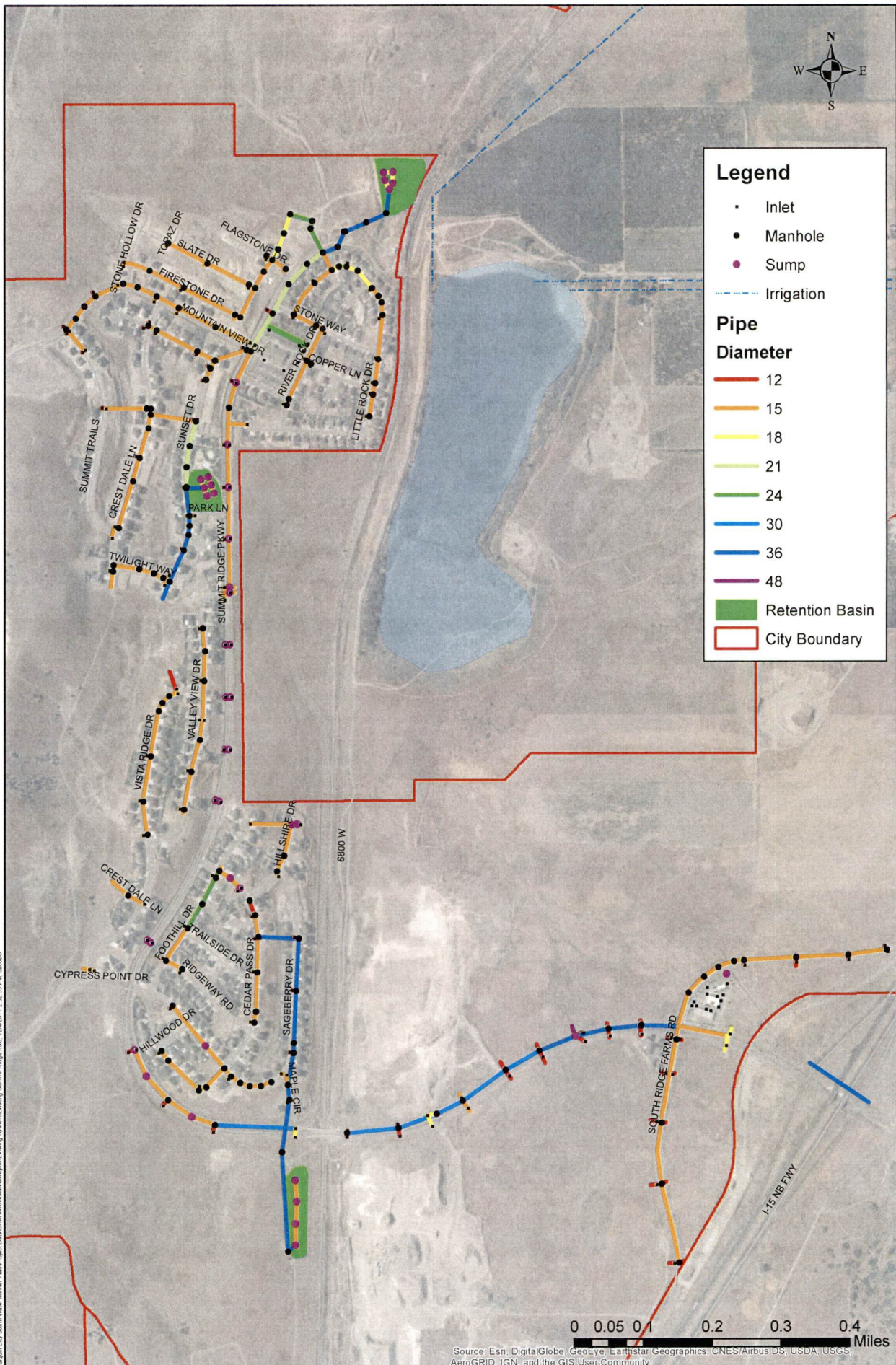

© 2017 PPG-135-1912 Summit Ridge Storm Water Master Plan Project Data\GIS\Stormwater\Summit Ridge.mxd, 12/4/2017 2:32:53 PM, Jacob O

Source: Esri, DigitalGlobe, GeoEye, Earthstar Geographics, CNES/Airbus DS, USDA, USGS, AeroGRID, IGN, and the GIS User Community



Existing System  
Summit Ridge

DATE	12/4/2017
DRAWN	
Figure 1	

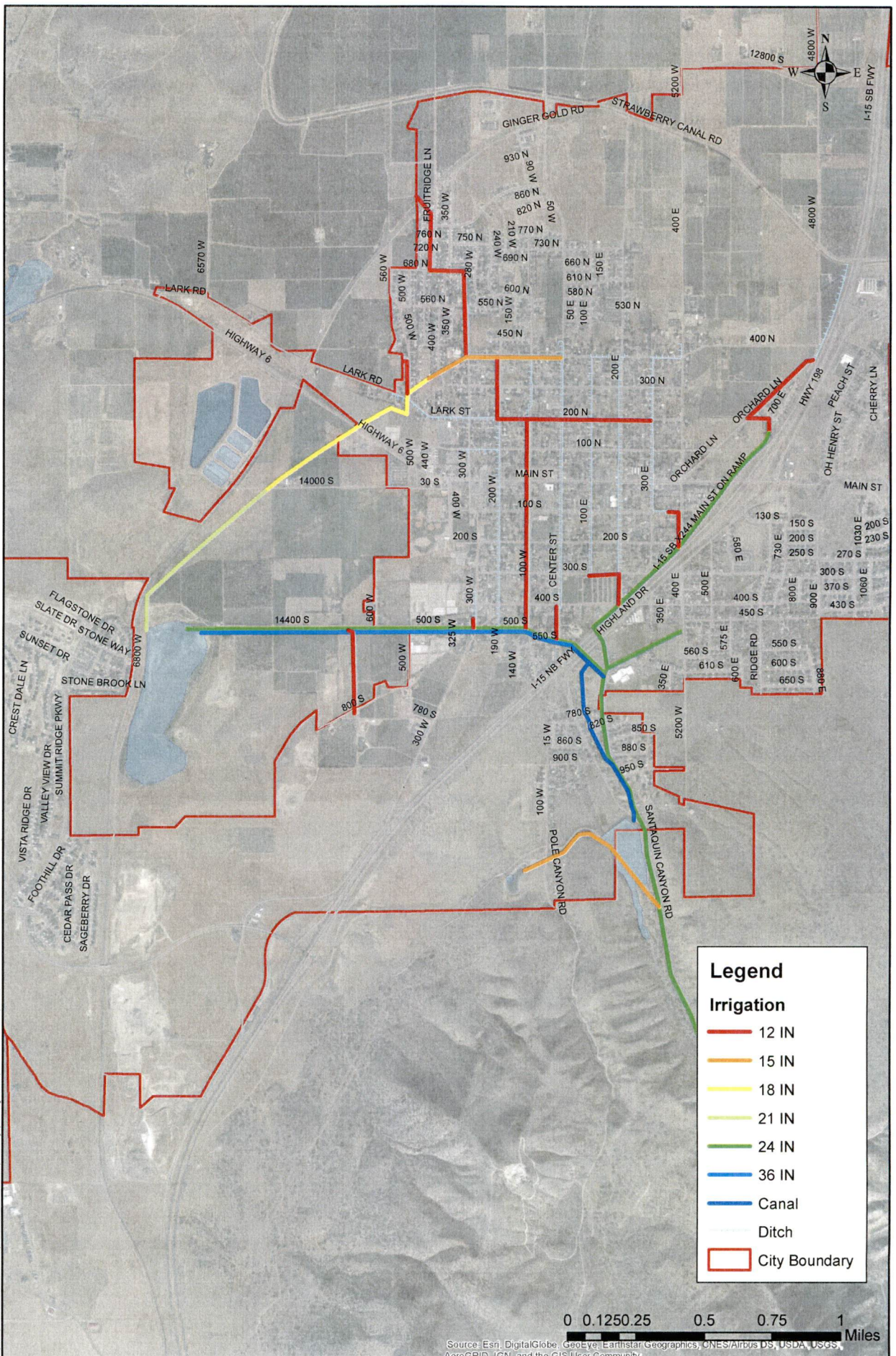

© 2020 BPS-133-1612, San Juan Co. Storm Water Management District. All rights reserved. 2/14/2018 12:47:13 PM. jwac0



**Existing Irrigation System**  
 Summit Creek Irrigation Company

DATE 2/14/2018

DRAWN

Figure 1

## HYDROLOGIC MODEL

To model the existing system, Bentley's PondPack V8i software program was used. Watersheds were modeled in their existing condition to determine peak flow rates and runoff volume. The runoff volume for each watershed was then compared to the available volume in sumps and retention basins located within the watershed in question.

## MODELING PARAMETERS

A 6-hour storm was used to determine the volumes. 25-year and 100-year return events were modeled. As previously stated, the NOAA 6-hour, 1<sup>st</sup> quartile 20% distribution was used. This temporal distribution used is one in which the majority of the storm occurs during the first quarter of the storm event.

Curve numbers were generated using USGS soil information together with existing land use and land cover data. Curve number tables were created for each combination of land use and soil type. The basis of the curve number classification is Chapter 9 of the USDA/NRCS National Engineering Handbook. ArcMap was used to create weighted average curve number values for each watershed. Curve number tables are included in Appendix H.

Time of concentration values were estimated using the Sheet Flow-Shallow Concentrated Flow-Channel Flow Method, as well as the SCS Lag Method.

## TOWN CENTER

The town center streets typically have a 99-foot right of way. Only 24 feet of this is used for the paved street. During small to moderate storms, most runoff infiltrates into the ground, ponds on the side of the road or enters a roadside ditch, where it eventually infiltrates into the ground. During large storm events, runoff will run north from block to block, and cause downstream flooding. A general plan to intercept 100-year storm runoff, retain it, and allow it to infiltrate on a very local level was investigated. This approach minimizes the need for large diameter pipe trunk lines or lengthy pipe systems. It also eliminates the need to purchase right of way for retention ponds and allows the City to focus on problem areas one block at a time.

Several scenarios were investigated for accomplishing the plan. Each scenario was analyzed using two sub scenarios: 1) with curb and gutter, park strip, sidewalk and a street overlay, and 2) with only the improvements needed for drainage. This helped determine the overall cost of improving the town center area versus the cost of only installing drainage improvements. The scenarios examined in detail are describe below.

---

## TOWN CENTER RIGHTS-OF-WAY

The wide rights-of-way in the center of town that are only partially paved present a unique opportunity for Santaquin to address drainage with Low Impact Development practices, and to maintain an attractive roadway design in the center of town. Limiting the asphalt to no more than 40 feet of width

(variable currently), the undeveloped shoulders can be utilized as natural drainage infiltration and conveyance swales. With sidewalks set back from the curb or uncontrolled edge of the asphalt allows a planter to be installed between them, as is generally shown in Figures 34 through 36 of the Santaquin Transportation Master Plan (InterPlan, 2014). The primary details from that plan representing this concept are copied below:

**Figure 6. 99 Foot Local ROW with Curb.**

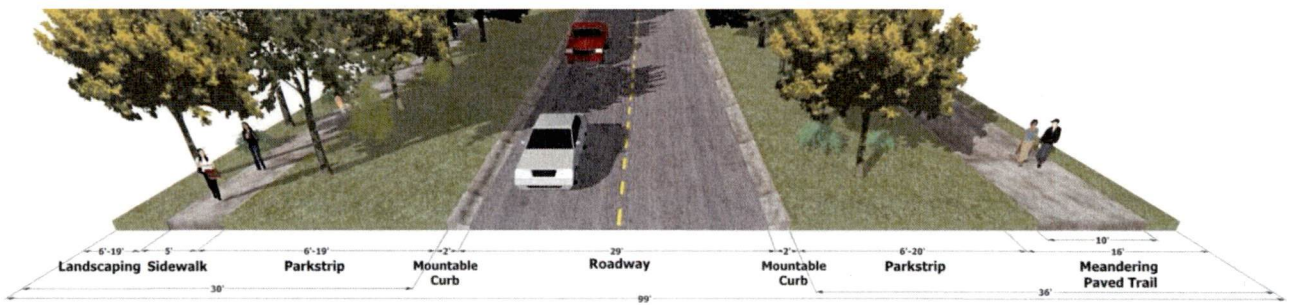

**Figure 7. 55 Foot Rural Local**

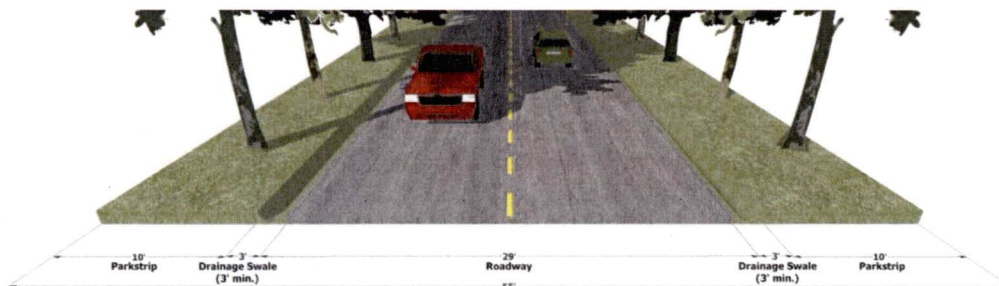

Also see [Figure 8, Storm Chambers Example](#) in this document.

The design of the local right-of-ways shall be in accordance with the following general criteria and Figure on page 59.

- Curb and Gutter is optional, but inlets or penetrations in the curb must be provided at regular intervals in order to control the spread in the road.
- Infiltration and conveyance systems can be installed below the drainage swales and park strips, with inlets being permitted in the grass swale itself to keep surface flows within acceptable limits.
  - Width of swales shall be based on an analysis of the size required to convey the necessary flows without exceeding maximum water elevation limits, provide infiltration, and may use the entire width of the park strip.
  - The volume and capacity of below ground storm water infiltration and conveyance facilities may be accounted for in the design.
  - Slopes in swales shall be no steeper than 4:1, and in no case shall the swale be deeper than fifteen inches from the top of curb.

- Concrete driveway accesses shall be constructed meeting typical standards for grade. Culverts of sufficient size shall be provided under the driveways to convey the full flow in the swale without overtopping, considering the entrance to be 50% plugged.
- Sidewalks or property grading must have sufficient rise to contain all flow in the right-of-way during the 100-year event,
  - Flows may not rise within 3 inches of the highest elevation of proposed or existing permanent infrastructure that can/will contain storm water within the right-of-way if adjacent pre-existing habitable buildings are below the elevation at the edge of the right of way
- Any berms used to prevent water from entering properties previously built lower than the road must have 4:1 slopes (max), a minimum top width of 4 feet, a maximum height of 1 foot, and construction practices or design measures must be employed that prevent undermining and seepage failures. Alternative concepts will be considered on a case-by-case basis by the City Engineer, at his discretion.
  - Water elevations during the 100-year event may not rise above 3 inches below the top of any such berm.
- All other 25-year and 100-year storm requirements discussed in this plan and any other criteria or documents adopted by city code must be met.

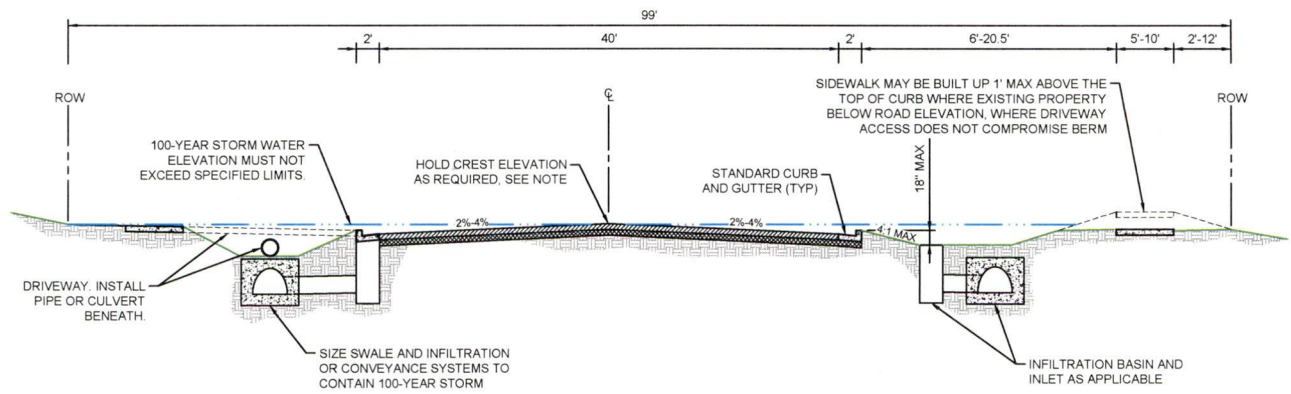

**TYPICAL TOWN CENTER ROW WITH CURB  
(99' ROW SHOWN)**

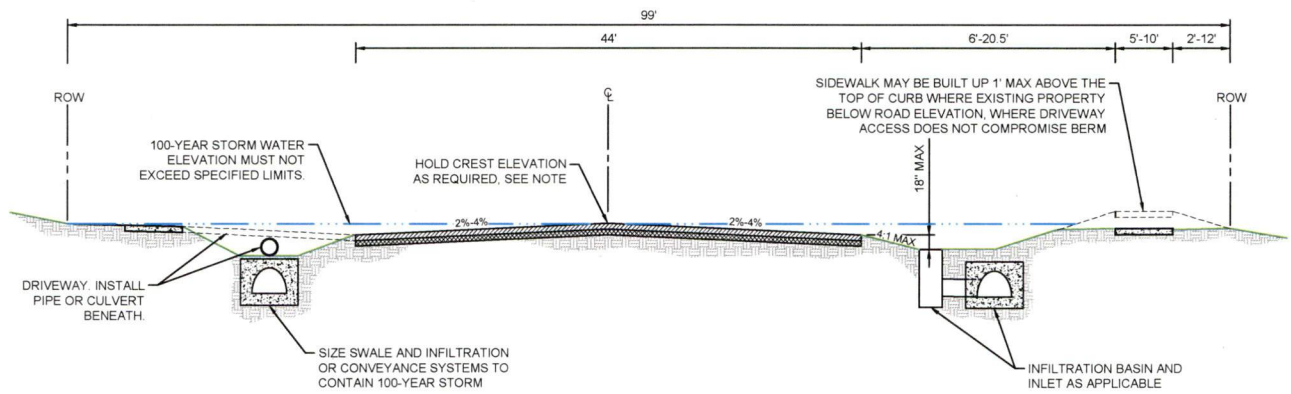

**TYPICAL TOWN CENTER ROW WITHOUT CURB  
(99' ROW SHOWN)**

**NOTE:**

1. 100-YEAR WATER ELEVATION MAY NOT ENCROACH WITHIN 6" VERTICALLY OF ANY HABITABLE STRUCTURE OR EXCEED THE EDGE OF RIGHT-OF-WAY.
2. 100-YEAR WATER ELEVATION MAY NOT RISE ABOVE AN ELEVATION OF 3" BELOW THE TOP OF ANY BERM OR THE EDGE OF RIGHT-OF-WAY IF ADJACENT EXISTING BUILDINGS ARE BELOW STREET LEVEL.
3. THE CROWN OF THE ROAD SHALL BE HELD TO EXISTING GRADE, UNLESS PERMITTED OTHERWISE BY CITY ENGINEER WHERE NEEDED TO ENABLE CONTAINMENT OF 100-YEAR STORM, TO MATCH GRADE AT ADJACENT PREVIOUSLY DEVELOPED PROPERTIES, OR TO MEET GRADE AT INTERSECTIONS.

---

### BLOCK BY BLOCK INFILTRATION GALLERY

This first scenario consists of intercepting storm runoff for each individual block and constructing a subsurface infiltration system to handle the runoff for the 100-year storm at the north end of the block. This advantage to the approach is that the storm runoff is intercepted and retained at a local level. It minimizes the need for long storm drain trunk lines that would have to be installed and maintained. It also keeps the storm runoff from traveling on to other downstream areas. This scenario can be constructed with or without curb, gutter and sidewalk.

---

### COMMON INFILTRATION PIPELINE

The second scenario consists of an infiltration trunk line constructed on every other street running from south to north. By combining the infiltration line into one continuous pipe, the number of maintenance points is reduced, accessibility of the infiltration gallery itself may be increased, and infrastructure is not required around every block. The trunk line runs nearly flat to improve infiltration and storage capacity. The line steps down in access boxes or manholes as the ground elevation drops. Each access structure has a weir or similar feature in it to force the pipe to fill to capacity before any flow can flow down to the next lower section of pipe. Smaller pipes convey flow from inlets on either side of the main, up to a block away, channeling the equivalent of two rows of blocks into one infiltration system. Traps, snouts, or other measures remove sediment and oils from the runoff prior to entering the infiltration basin. Drainage swales, the natural grade, or curb and gutter convey surface flows to the inlets.

---

### TWO-BLOCK INFILTRATION GALLERY

The third scenario investigated is very similar to the first scenario. The primary difference is that an infiltration system is constructed for two square blocks instead of for one. This approach requires the ability to connect the block on the south to the block on the north. Thus, it likely will not work with the “no curb and gutter approach”

The scenarios were evaluated based on cost, amount of maintenance and feasibility. It was found that they are all relatively equal. The cost for each scenario is very close. The scenarios with more subsurface retention locations have less pipe to maintain, and vice versa.

Detailed cost estimate information and applicable figures are located in Appendix C.

---

### LOCALIZED STORM CHAMBERS

Another approach to handling the storm runoff is to install sub-surface storm water chambers without any sort of pipe trunk system. The storm chambers would be constructed between the curb and the sidewalk in a landscaped swale area. Storm drain inlets located within the curb and gutter are piped to a precast concrete box located within the swale. This box would have two pipes extending in either direction to a row of storm chambers.



This approach is utilized in the neighboring community of Spanish Fork. An example from Spanish Fork City Standard Drawings is included below as Figure 8.

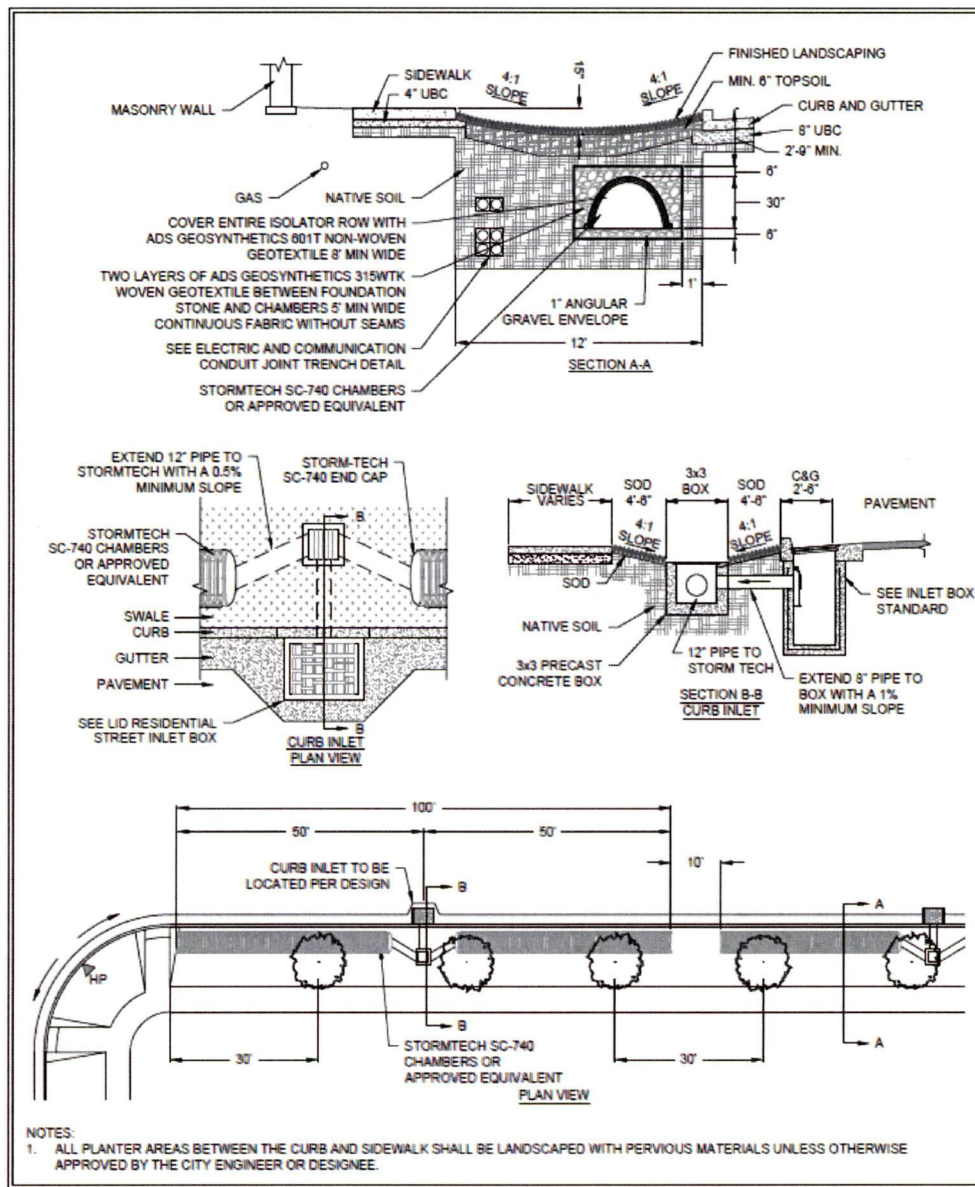

Figure 8. Storm Chambers Example

## HILLSIDE AREAS

The east bench hillside is a major concern as post-burn debris flows have destroyed homes and property and put lives at risk. This area will continue to develop and as such, will continue to be at risk of flooding under burned-over conditions followed by heavy storms.

Some flood control improvements have been made in recent years to protect homes from flooding. At the base of the watershed known as Broad Hollow, a cut off channel was constructed to divert flows around residential development. This channel eventually tapers off and terminates just above a residential property. It currently puts the downstream property at risk. At the base of the watershed known as Oak Hollow, a J-hook channel has been constructed to divert flows away from residential development and to a broad drainage path that drains between Dairy Queen and True Value. In the event that water reaches this location, it eventually flows across the highway, along I-15 and to the Highline Canal. These two existing cutoff channels are considered temporary fixes, as they do not provide a suitable outfall for large runoff or debris flows.

The hillside areas on the east bench were modeled using a combination of several different methods and return events to determine peak flow rates and volumes. The first method assumes a "clear water" runoff volume for the 100-year event.

The second method assumes burned conditions in the watershed during a 25-year event. Burned conditions cause more rapid runoff due to a lack of vegetation and altered soils. Peaks flows can increase dramatically, and the volume of runoff increases. The runoff is sediment laden, increasing the volume of the runoff and depositing sediment below the watershed. Sediment volume can vary up to approximately 20% of the "clear water" runoff volume before it is considered a debris flow. A 20% sediment load was assumed for our bulking calculations for planning level design.

The third method was to assume debris flows occur, which is essentially a fluid mud carrying debris along with it. Debris flows have a large mass and can cause severe damage to property and structures, while leaving a thick deposit of mud and debris. Debris volumes were calculated using a 5-year rainfall event and a debris volume formula developed by Cannon, et al. (2010) for the Intermountain West.

The following figure shows the east bench watersheds, with their associated burned condition runoff volume.

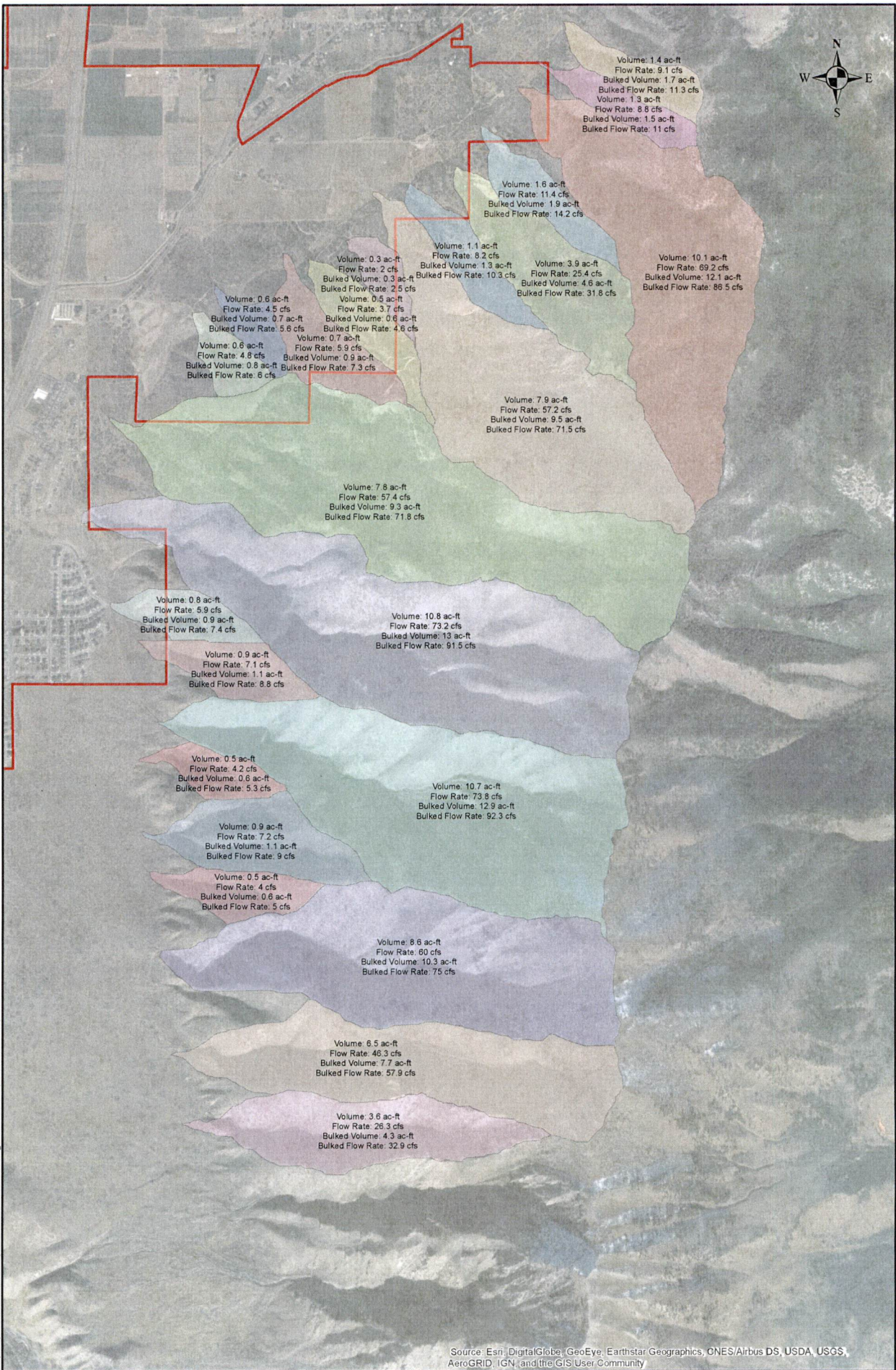

Source: Esri, DigitalGlobe, GeoEye, Earthstar Geographics, CNES/Airbus DS, USDA, USGS, AeroGRID, IGN, and the GIS User Community

© 2021 EPC-1331612, San Juan Co. Storm Water Master Plan/Project Data/SHorrocks/Mar/Est/Bech, Burned Conditions.mxd, 2/23/2018 10:31:46 AM, JacoD



25-Yr Burned Conditions  
East Bench

DATE	2/23/2018
DRAWN	
CHECKED	

Runoff volumes and peak flow rates for the east bench watersheds are included in Appendix I.

Based on discussion with Santaquin City, the location and proximity of existing residential development along the east bench, and the location of developable land, six watersheds have been selected as “High Priority” watersheds. A debris basin for each of these watersheds will be included in the capital facilities fee portion of this report.

## EXISTING DEFICIENCIES

Existing deficiencies in the storm drain and flood control system were determined using four methods: public input and comments, knowledge of city staff, hydrologic modeling efforts, and field investigation.

## PUBLIC COMMENTS

Multiple efforts were employed to gather public input for any known storm water or flood problems. A public comment map website was utilized to gather comments online in a GIS format. A public meeting was held to provide residents with an opportunity to provide comments and discuss any concerns in person. Computers were available for residents to make comments and record the geographic location that pertains to their comment. Banners were placed at strategic locations throughout the city to advertise for the public meeting. Most comments pertained to specific flooding problems throughout the city. Other comments had to do with the installation of curb and gutter, sidewalk, how the improvements would be paid for, or why they are needed.

A map showing public comments received is shown on the following page.

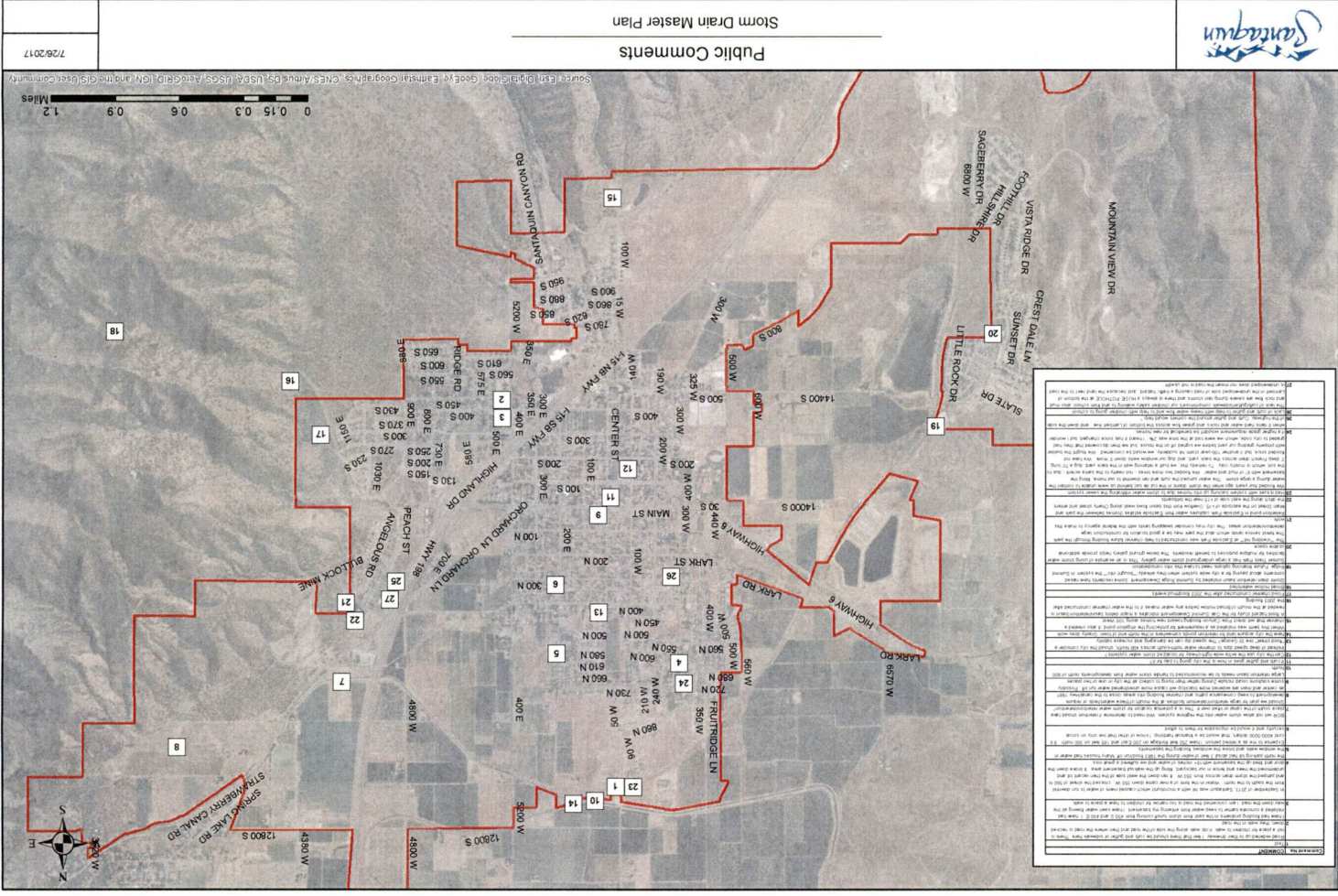
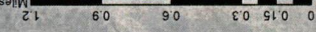

Parcel ID	Comments
1	
2	
3	
4	
5	
6	
7	
8	
9	
10	
11	
12	
13	
14	
15	
16	
17	
18	
19	
20	
21	
22	
23	
24	
25	
26	
27	
28	
29	
30	
31	
32	
33	
34	
35	
36	
37	
38	
39	
40	
41	
42	
43	
44	
45	
46	
47	
48	
49	
50	
51	
52	
53	
54	
55	
56	
57	
58	
59	
60	
61	
62	
63	
64	
65	
66	
67	
68	
69	
70	
71	
72	
73	
74	
75	
76	
77	
78	
79	
80	
81	
82	
83	
84	
85	
86	
87	
88	
89	
90	
91	
92	
93	
94	
95	
96	
97	
98	
99	
100	

## CITY STAFF

Input regarding current flooding problems was also provided by city staff. The Public Works Director has been with the city many years and has a broad knowledge of where and why drainage problems exist.

## HYDROLOGY MODEL

The hydrologic model was used to determine excess runoff volume. With the exception of Summit Ridge and portions of the north end of town, pipe systems within the city were not designed to convey runoff from large portions of the city. Rather, they were installed for localized developments, to get the runoff to an infiltration gallery or a retention facility. Generally, they were designed to convey the 25-year storm. For this reason, only select segments of the storm drain trunk lines were modeled. The following trunk lines were modeled to ensure they have adequate conveyance capacity for the 25-year storm runoff: 1030 East/Oak Summit; Apple View area; Ginger Gold, Royal Land, 860 North and North Center; and north 350 West. It was determined that all of the pipes modeled have adequate conveyance capacity for the existing system and for the foreseeable future development that will occur near and discharge to them, with the exception of the 350 West trunk line. The 350 West trunk line flow rates will be reduced through the construction of a redundant system that takes flows to the park at 750 North.

The trunk lines were analyzed using the rational method; the analysis is based on the assumption that all of the runoff actually enters the pipe system. This is somewhat conservative because storm drain inlets do not capture 100% of the runoff. See Appendix K for pipe analysis output.

Available retention volume in each watershed was compared with the runoff volume. Retention volume includes both sump and retention pond volume. In general, the model indicated that the available storage volume was approximately one third of the runoff volume. This does not necessarily mean there are flooding problems in all areas, but that water is ponded on the sides of streets, flowing to other areas, etc. For example, large agricultural areas will not have a flooding problem, as they are able to infiltrate the runoff. Runoff that is not infiltrated in these agricultural fields or orchards will not cause significant flooding problems because there are no structures or improvements located there.

Runoff volumes in residential and commercial developments were evaluated closely. Locations where the modeled runoff volumes are much higher than available retention volume were flagged and examined in conjunction with data from public comment and known flooding problems. It was discovered that the areas where the runoff volume was much higher than the available retention volume correlated very well with known problem areas.

## FIELD INVESTIGATION

Field investigations were performed in an effort to verify problems associated with public comments, to verify existing drainage patterns, and to discover other miscellaneous drainage problems. Visible problems include signs of erosion where curb and gutter terminate and runoff apparently flows by. In addition, the drainage cut off ditch for the Broad Hollow watershed terminates just above a new development.

## PROPOSED PROJECTS TO ADDRESS DEFICIENCIES

Deficiencies outlined below are listed in order of priority.

1. Flooding problems near 330 West and 650 North: A new storm drain system should be constructed in the surrounding roads to convey storm water to the park at 750 North. A 2.5 acre-ft turf retention basin should be constructed in the park.
2. Hillside debris basins are needed at six east bench watersheds located near existing and proposed residential developments. Although a cut off channel has been constructed at the base of Broad Hollow, the channel abruptly terminates above a residential development. In the event that a debris flow occurs, the channel would direct flows directly at the residential development. Debris basins should be constructed at the base of each of these watersheds. The estimated basin volumes are included in a separate EA document. The basins are primarily an existing deficiency, although they will also benefit future development (67% existing, 33% future). It is assumed that Santaquin City will pay for the land and right-of-way costs, while NRCS will pay the remaining amount.
3. Inadequate retention volume in the development bound by 900 East, 690 East, 650 South, and 150 South (Southeast Bench A): A storm drain system should be constructed to intercept and convey runoff that overwhelms the existing sump system. It should convey the runoff to a 3.5 acre-ft retention basin located in the 150 South vicinity. The basin would hold the 25-year runoff volume. Volumes for larger events would overflow and flow alongside Highland Drive and eventually to the I-15 interchange.
4. Inadequate retention volume in the development bound by 650 South, 450 South and 690 East to 400 East (Southeast Bench B): A storm drain system should be constructed to intercept and convey runoff that overwhelms the existing sump system. It should convey the runoff to a 1.3 acre-ft retention basin located at 400 East in the historic wash.
5. Inadequate retention volume 750 North: in the development bound by 500 North, 750 North 240 West, and 350 West. An improved storm drain system should be constructed to convey runoff to a 2.5 acre-ft retention basin to be constructed at the Park at 750 North.
6. Inadequate Retention Volume North 350 West. A pipe and sump system exists in 350 West that runs north and terminates near the railroad. A retention basin should be constructed at this location. The volume required to address existing deficiencies is approximately 1 acre-ft. However, because this pond would be located at the north end of town where more development is and will continue to occur, enlarging the basin for future growth should be considered.
7. Local flooding in the vicinity of 400 East and 400 South: Runoff flowing in the gutter along 400 East gets to the point where the gutter terminates and can flow over the road and continue flowing northward on the side of the road. To remedy this problem curb and gutter should be extended from 450 South to 300 South. A storm drain system should be installed which conveys flows north to the triangular piece of land at 300 South. A 0.4 acre-ft retention basin should be constructed at this location.

flows north to the triangular piece of land at 300 South. A 0.4 acre-ft retention basin should be constructed at this location.

8. Lack of retention at 680 N and 560 W. Although this is not currently an immediate problem, this area has inadequate retention. A retention basin should be constructed with a volume 0.4 acre-ft for the 25-yr event.
9. Town Center Drainage: The older part of town has been developed without a storm drain system. As water runs from south to north, it may enter existing irrigation ditches, pond along the side of the road, or continue to flow north. Localized subsurface retention systems should be constructed to prevent future flooding during large storm events. The proposed drainage infrastructure may include the installation of other improvements such as curb and gutter and sidewalk. Options and cost estimates for improving the town center are included in Appendix C of this report.
10. Drainage discontinuity at Lambert and State Highway 198: The drainage catch basin/sumps at the bottom of the hill should be improved. They currently have a grated circular lid. They are inefficient at intercepting runoff. Additional small inlets should be constructed adjacent to them to help pick up the runoff and direct it to the sumps. Ultimately, the curb and gutter should be wrapped around the corner and extended northward to connect to the curb and gutter in front of C.S. Lewis Academy. The curb and gutter will also need a suitable outfall. Because this is a State road, coordination with UDOT to determine the outfall location and the cost responsibilities.
11. NRCS Channel is in disrepair: This is a Utah County facility constructed by the NRCS that has a potential flood impact on Santaquin City. The channel should be repaired and regraded to maintain a complete connected path from the NRCS basin to the I-15 interchange. This work should be completed in conjunction with NRCS and Utah County. For this reason, a cost estimate has not been included.

Maps of the existing deficiencies are shown on the following three pages.



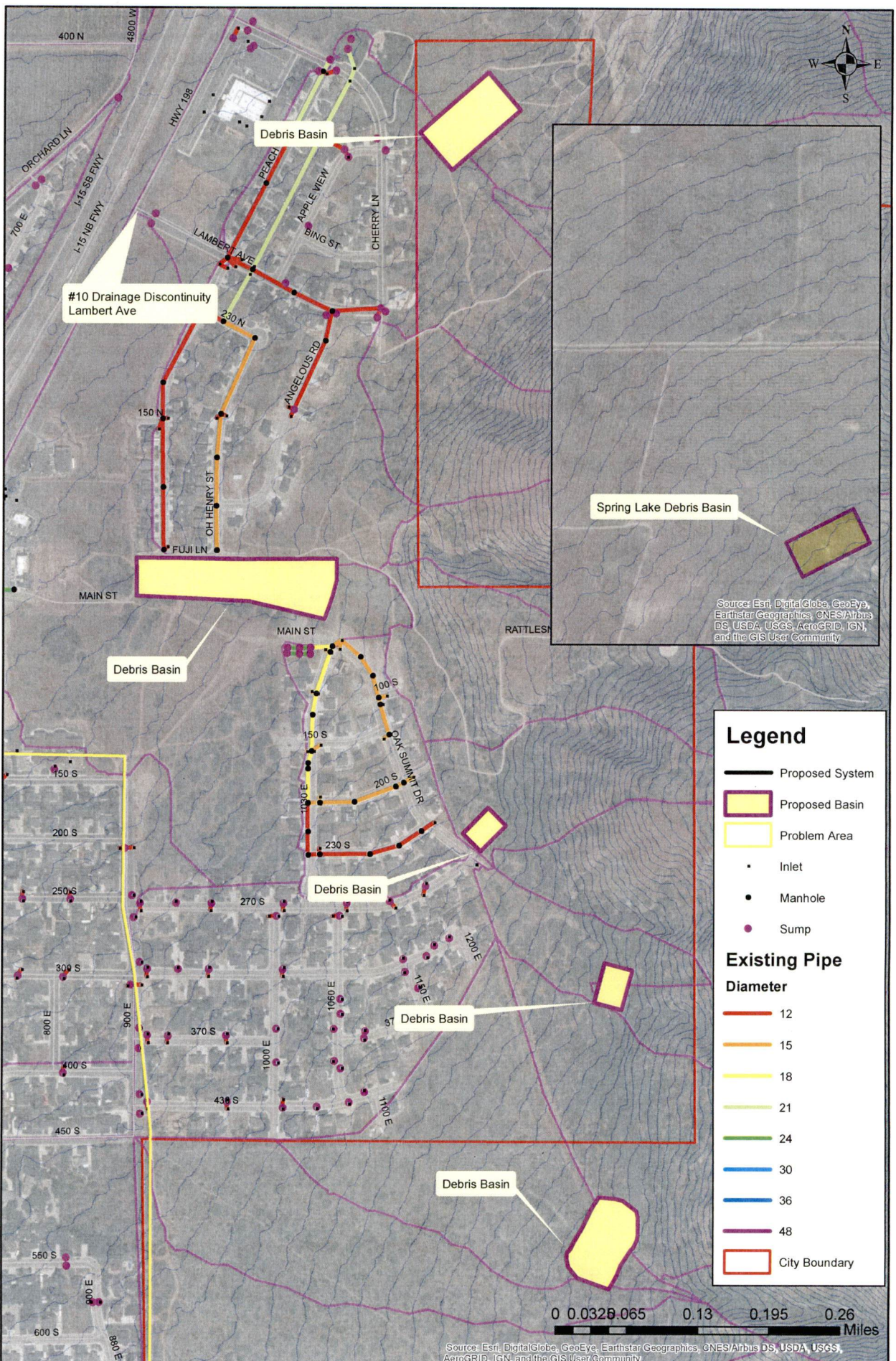

012018P01-135-0172 - Santaquin City Storm Water Master Plan/Project Chan/3D/Stormrock/Mud/Report/Existing Deficiencies/Debris Basins.mxd, 10/22/2018 3:32:24 PM, Jacqui



**Existing Deficiencies**  
**Debris Basins**

DATE	10/22/2018
DRAWN	

Source: Esri, DigitalGlobe, GeoEye, Earthstar Geographics, CNES/Airbus DS, USDA, USGS, AeroGRID, IGN, and the GIS User Community

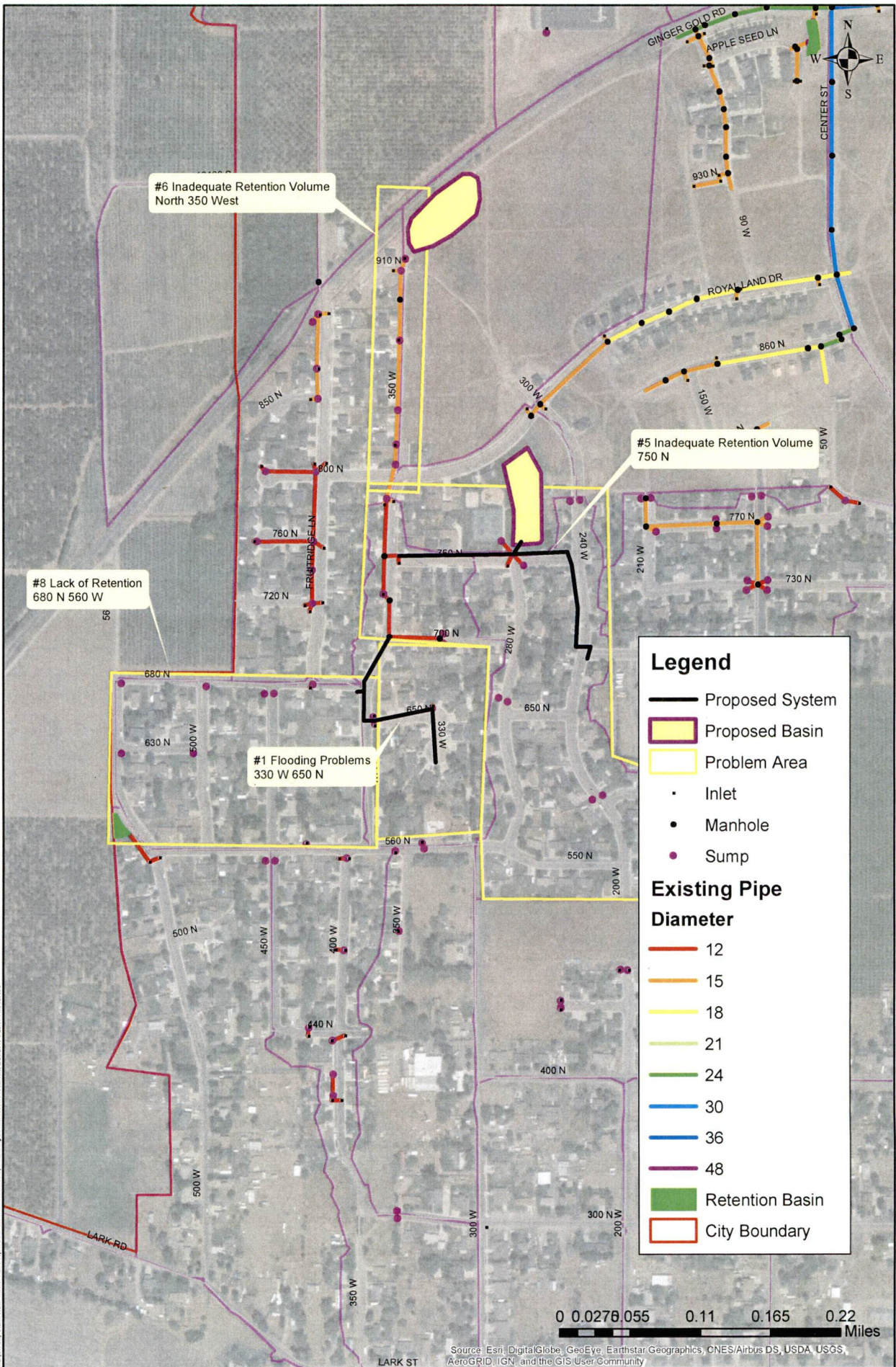

C:\2018\BPC-113-1612\Santaquin\_City\_Storm\_Water\_Master\_Plan\Figures\Drawings\Shoreline\Map\Report\Existing\_Deficiencies\NW\_Quad.mxd 2/20/2018 3:30:57 PM JacobO



Existing Deficiencies  
Northwest Quadrant

DATE	2/20/2018
DRAWN	

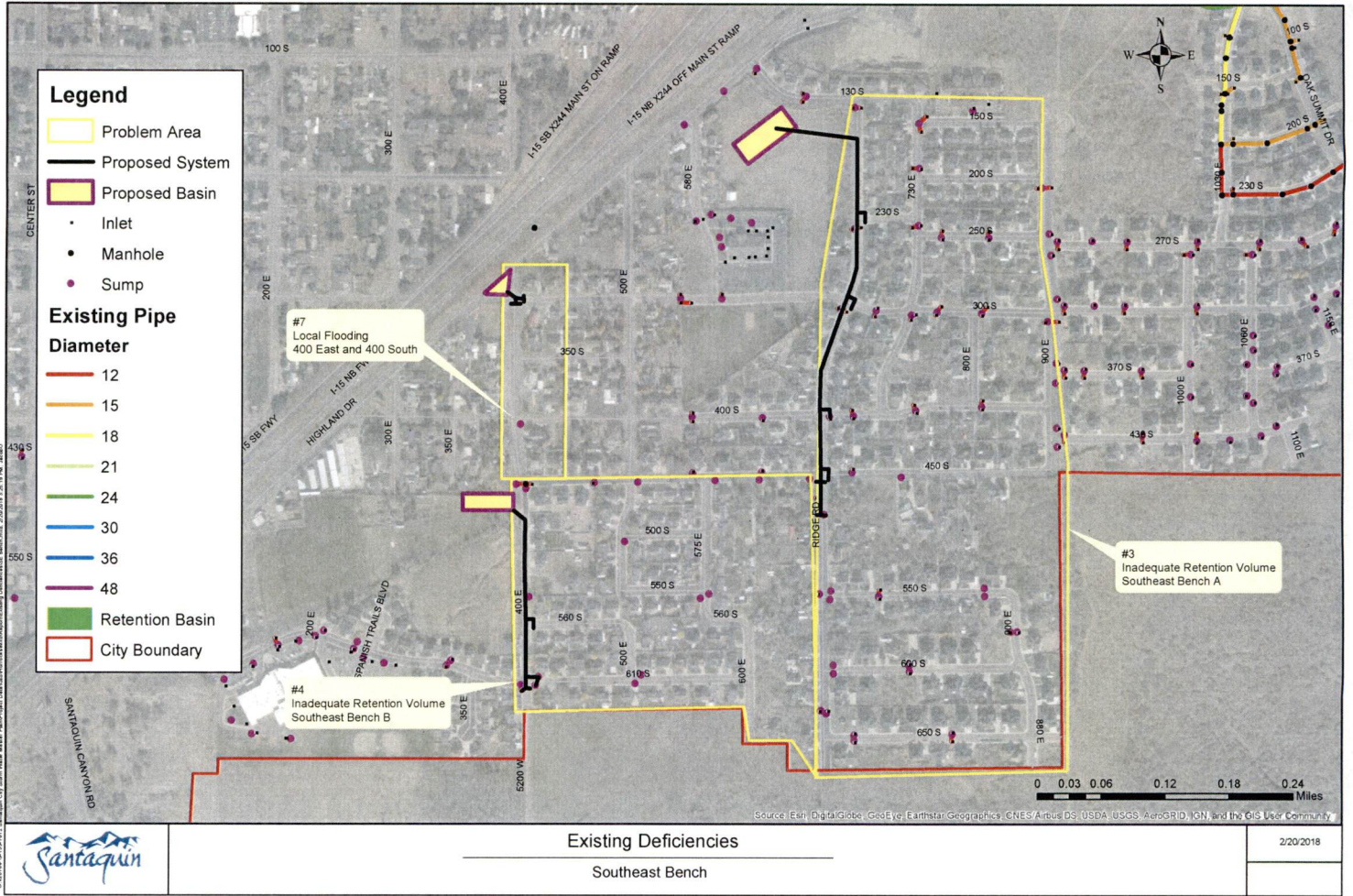

Existing Deficiencies  
Southeast Bench



## COST ESTIMATE FOR PROPOSED PROJECTS FOR EXISTING DEFICIENCIES

The following table shows the total estimated cost to rectify existing deficiencies. The costs include material, construction, right-of-way, utility relocation, repaving, engineering costs, etc.

**Table 12. Existing Deficiency Costs**

Item	Description	Cost (million \$)
1	330 West and 650 North Storm Drain System	\$ 0.43
2	Hillside Debris Basins	\$ 12.3 (2.8* paid by Santaquin as exiting deficiency)
3	Southeast Bench (A) Storm Drain System and Retention Basin	\$ 0.90
4	Southeast Bench (B) Storm Drain System and Retention Basin	\$ 0.52
5	750 North Park Retention Basin	\$ 0.32
6	North 350 West Retention Basin	\$ 0.22
7	400 East and 400 South Improvements	\$ 0.16
8	680 N and 560 W Retention	\$ 0.12
9a	Town Center Drainage (assuming 56 blocks, \$0.20M each; includes drainage improvements only)	\$ 11.2
9b	Town Center Drainage (assuming 56 blocks, \$0.52M each; includes curb and gutter, sidewalk, road widening, resurfacing, planter, etc.)	\$ 29.1
10	Lambert and State Highway 198 Drainage Improvements	\$ 0.04
11	NRCS Channel (\$0.55M to be paid for by others)	\$ 0.0
	<b>Grand Total (With Option 9a)</b>	<b>\$ 16.7</b>
	<b>Grand Total (With Option 9b)</b>	<b>\$ 34.6</b>
	<b>Grand Total (With no Town Center)</b>	<b>\$ 5.5</b>

\* 67% of \$8.4M paid for land costs and 5% of construction costs

## METHODS OF FINANCING EXISTING DEFICIENCY PROJECTS

Several methods of financing the proposed projects can be employed by the city. Some of these methods include user fees, taxes levied through the formation of a special improvement district, issuing

bonds, and use of general funds. Grants or loans through government agencies can also be applied for to assist in funding these projects.

Special improvement districts are generally used to cover areas with multiple municipalities, and are complex to create, and are not recommended in this case. User fees are easiest, but are not well accepted if excessive. Bonds are often effective to address specific needs that are supported by the general public. Our recommendation is to use a combination of user fees for general maintenance, repair and very small projects spread throughout the city, and bonds for specific significant projects, such as the existing deficiencies previously listed in this report, including town center improvements.

The following analysis summary demonstrates the magnitude of cost and user fees associated with bond repayment. The analysis below does not include operations and maintenance costs. The maintenance costs should be determined by examining O&M costs from recent years. This cost would be an addition above the user fee cost estimated below.

Option A: All existing deficiencies with *only drainage improvements* in the town center

- Implementation Period: 20 years
- Present cost: \$16.7
- Assumed Interest Rate: 5%
- Total Annual Payment: \$1,338,446
- Annual Payment per "Connection": \$425.71
- Monthly Payment per "Connection": \$35.48

Option B: All existing deficiencies with *full improvements* in the town center

- Implementation Period: 20 years
- Present cost: \$34.6M
- Assumed Interest Rate: 5%
- Total Annual Payment: \$2,774,779
- Annual Payment per "Connection": \$883
- Monthly Payment per "Connection": \$73.55

Option C: All existing deficiencies with *no improvements* in the town center

- Implementation Period: 20 years
- Present cost: \$5.5M
- Assumed Interest Rate: 5%
- Total Annual Payment: \$439,729
- Annual Payment per "Connection": \$140
- Monthly Payment per "Connection": \$11.66

The results shown below are based on the assumption that all existing deficiencies are corrected and that a loan or bond is paid for over a 20-year period. To decrease the user fee, a longer payback period may be used, or fewer projects could be bonded for, leaving the other deficiencies to be addressed in the future.

The analysis summary is based on the current number of households and businesses that receive a City utility bill (3,144 at inception). As the City expands and more residents and businesses are available to share in the cost of the bond payment, the user fee may be reduced accordingly. See the table below for an example of this concept for the Town Center Drainage-Only option.

**Table 13. User Fee**

No. Years	Year	Growth Rate	New Connections	Total Connections	Yearly Payment	Yearly Payment per Connection	Monthly Payment per Connection
	2018	6.18%	0	3144			
1	2019	6.22%	196	3340	(\$1,340,051.21)	(\$401.26)	(\$33.44)
2	2020	6.20%	207	3547	(\$1,340,051.21)	(\$377.82)	(\$31.48)
3	2021	3.71%	131	3678	(\$1,340,051.21)	(\$364.31)	(\$30.36)
4	2022	3.71%	137	3815	(\$1,340,051.21)	(\$351.27)	(\$29.27)
5	2023	3.71%	141	3956	(\$1,340,051.21)	(\$338.71)	(\$28.23)
6	2024	3.71%	147	4103	(\$1,340,051.21)	(\$326.59)	(\$27.22)
7	2025	3.71%	152	4255	(\$1,340,051.21)	(\$314.90)	(\$26.24)
8	2026	3.71%	158	4413	(\$1,340,051.21)	(\$303.64)	(\$25.30)
9	2027	3.71%	164	4577	(\$1,340,051.21)	(\$292.78)	(\$24.40)
10	2028	3.71%	170	4747	(\$1,340,051.21)	(\$282.31)	(\$23.53)
11	2029	3.57%	169	4916	(\$1,340,051.21)	(\$272.60)	(\$22.72)
12	2030	3.86%	190	5105	(\$1,340,051.21)	(\$262.47)	(\$21.87)
13	2031	3.05%	156	5261	(\$1,340,051.21)	(\$254.70)	(\$21.22)
14	2032	3.05%	160	5422	(\$1,340,051.21)	(\$247.16)	(\$20.60)
15	2033	3.05%	165	5587	(\$1,340,051.21)	(\$239.85)	(\$19.99)
16	2034	3.05%	170	5757	(\$1,340,051.21)	(\$232.75)	(\$19.40)
17	2035	3.05%	176	5933	(\$1,340,051.21)	(\$225.86)	(\$18.82)
18	2036	3%	181	6114	(\$1,340,051.21)	(\$219.18)	(\$18.27)
19	2037	3%	187	6301	(\$1,340,051.21)	(\$212.69)	(\$17.72)
20	2038	3%	192	6493	(\$1,340,051.21)	(\$206.40)	(\$17.20)

No storm drain user fee is currently collected. As user fee based projects are completed, fees related to the construction of the projects may need to be maintained and adjusted as necessary, to begin to address replacement costs. Future master plan updates should examine whether maintenance needs required adjustments to this approach.

## NEEDS FOR FUTURE GROWTH

As the city becomes more developed, and approaches its buildout condition, a plan of infrastructure needs for future buildout must be followed. As there is no major outfall channel located within the city, most of the runoff will be retained in local or regional retention basins. These retention basins will typically be constructed as part of a development project. However, there may be key developments in which it may be more prudent for the city to participate in the maintenance and ownership of the retention basin (HOA's may become defunct, or commercial developments may close, etc.). General descriptions of types of recommended future projects are listed below, followed by further detail for each item.

- Extension of the Santaquin Canyon debris basin spillway conveyance channel down to the Summit Creek Irrigation Company's reservoir.
- Additional debris basins in the mountain watersheds. Debris basins have been recommended where the required volume is 2 acre-ft or above, and there is a significant hazard to proposed development.
- Retention basins in the planned commercial and industrial areas on the west and southwest portions of the city, and in its anticipated annexations.

## SPILLWAY CONVEYANCE CHANNEL

The spillway for the Santaquin Canyon Debris Basin currently drains into a channel that conveys the flows away from developed areas and discharges near the I-15 ramp in the southwest part of the city. Large flows can currently pass under the freeway overpass, spread across the fields north of the ramp, and terminate in the irrigation reservoir.

In order to enable and protect current and future development and infrastructure, a defined channel must be constructed to convey the spillway flows to the reservoir. The nature and size of the channel vary with the grade and channel design, but an open channel would be in the range of 33 feet wide at the top, 3 feet deep, with 3:1 (H:V) side slopes.

With the formalizing of the discharge route, and in consideration of the historical use of the drainage path, responsibility for the mitigation of the effects of the introduction of such drainage into the reservoir should be formalized between all interested parties, including the Summit Creek Irrigation Company, Santaquin City, Utah County, the NRCS, and the State of Utah Dam Safety Section, as applicable.

The channel could potentially take several forms. An open channel is recommended for maintenance and cost reasons. Drainage down a custom designed street, through swales in open park areas or between properties, or even pipes or box culverts could be considered. An enclosed system would allow development or roads to be constructed over the system, maintaining valuable land, but is considerably more costly.

## DEBRIS BASINS

As the city grows, development is anticipated to encroach on the alluvial fans of the mountain watersheds that currently do not present significant hazards. To protect these developments, debris basins or other measures will be required. It is recommended that developers be required to conduct studies and install the mitigation measures necessary to protect their developments.

In some cases runoff and debris flows from these watersheds may present a hazard to more than one development, or to other infrastructure, or the size of the structure may not be economically feasible for a single development. In these cases, the city may wish to participate in the construction of the necessary improvements using impact fees or other funds.

As stated previously, Santaquin City is currently working with NRCS to plan for debris basins and/or other flood control measures along the east bench. This work is in a planning phase with the intent that it will continue to full design and construction.

Design recommendations for debris control flood control structures are included in the Design Guidelines section of this report.

## RETENTION BASINS IN COMMERCIAL AND INDUSTRIAL AREAS

The recommended standard design criteria would require nearly all-commercial and industrial development in the city to retain the full 100-year event. In order to encourage commercial and industrial development, and to not overburden smaller commercial developments, it is recommended that some regional basins be installed in the undeveloped areas in the west and southwest side of the city. These basins would retain any excess runoff beyond the 25-year event (25-year event would still be retained onsite), and could be fed by means of surface flows in streets or other channels since the regional basins will only be needed in extreme events. Therefore, no conveyance infrastructure will be required.

There are various methods of implementing regional retention:

---

### REGIONAL PONDS

A few regional ponds could be installed in strategic locations to capture flows beyond the 25-year precipitation event. Located correctly, in most cases already planned infrastructure such as roads and channels could convey the storm water to the ponds without the need for additional conveyance infrastructure.

---

### PARK STRIPS

To maintain a more localized approach, retention basins could be incorporated into the park strips alongside major arterials or collectors, with perhaps some additional ROW dedication required by the adjacent property owners to allow adequate sizing, as needed.



---

#### RETENTION IN THE SANTAQUIN CANYON SPILLWAY CHANNEL

In order to make the most efficient use of the property dedicated to the Santaquin Canyon Debris Basin spillway channel, it may be possible to create some retention basins within the channel itself. Water could be retained by installing concrete weir walls and basins in the bottom of the channel, though the structures would be required to pass the estimated 400 cfs from the Santaquin Canyon spillway channel. If in-channel retention is not possible, the channel could still be used to convey excess flows to a regional pond without requiring additional pipe conveyance infrastructure. The peak flows from local discharge and the spillway are unlikely to coincide.

A map showing the projects recommended for future growth is on the following page.

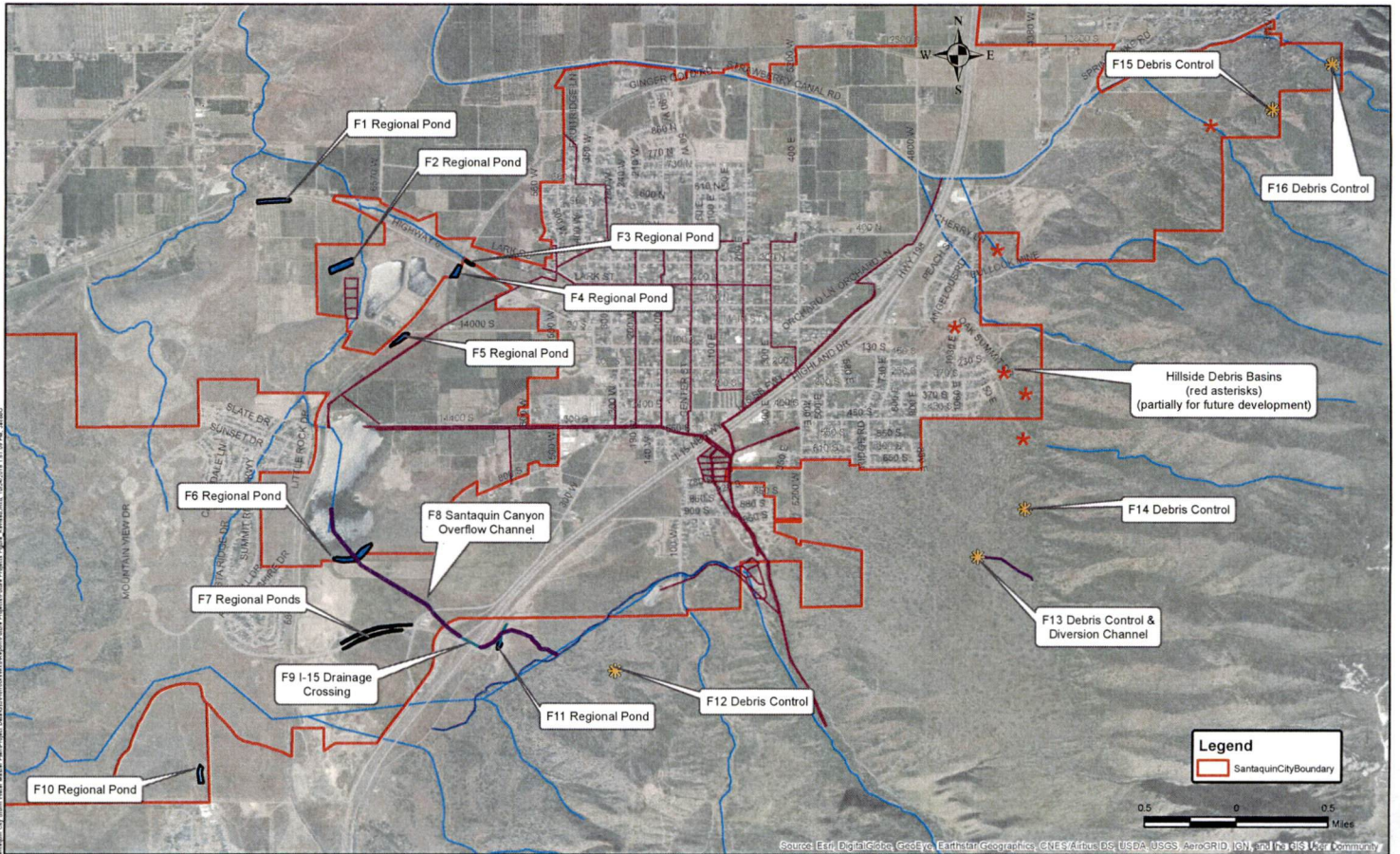

Projects Required Entirely for Future Development

10/24/2018

## RECOMMENDED FUTURE GROWTH PROJECTS

Specific recommended projects are outlined in Table 14, and described more specifically in the following section. Cost estimates and designs are based on planning level analysis and assumptions. Approximate property acquisition costs, final designs, and refined cost estimates should be prepared for each project at the time of implementation. In some cases, there may be multiple viable options for a listed project, but the options presented should ensure adequate funds have been procured for whatever option is ultimately installed. Some potential alternatives will be identified in the project specific descriptions following the table. A figure of the proposed projects is included on the previous page.

The projects are in no specific order; priority will be outlined in the Capital Facilities Plan portion of this report. All costs are based on current rates as of December 2017.

**Table 14. Future Growth Project Costs**

Item	Description	Size	Cost (millions)
F1	Northwest Industrial Regional Pond #1	3.1 ac-ft	\$ 0.38
F2	Northwest Industrial Regional Pond #2	6.7 ac-ft	\$ 0.65
F3	Railroad Corridor Industrial Regional Pond #1	1.0 ac-ft	\$ 0.12
F4	Railroad Corridor Industrial Regional Pond #2	3.1 ac-ft	\$ 0.33
F5	Railroad Corridor Industrial Regional Pond #3	3.2 ac-ft	\$ 0.34
F6	Summit Creek Reservoir Regional Pond	8.4 ac-ft	\$ 0.93
F7	Summit Ridge Parkway Regional Pond	11.0 ac-ft	\$ 1.04
F8	Santaquin Canyon Overflow Channel	24 to 33 ft <sup>†</sup>	\$ 2.25*
F9	Santaquin Canyon Overflow Channel – I-15 Crossing	10'x4' Culvert	\$ 0.95*
F10	Western Commercial Regional Pond	3.0 ac-ft	\$ 0.37
F11	South Off-Ramp Commercial Regional Basin	0.5 ac-ft	\$ 0.17
F12	South Mountains Debris Control Structure	2.4 ac-ft	\$ 0.35
F13	Southeast Bench Debris Control Structure #1 and Diversion Channel	10.3 ac-ft	\$ 1.09
F14	Southeast Bench Debris Control Structure #2	2.6 ac-ft	\$ 0.35
F15	Spring Lake Debris Control Structure #1	4.6 ac-ft	\$ 0.55*
F16	Spring Lake Debris Control Structure #2	12.1 ac-ft	\$ 1.40*
	<b>Grand Total</b>		<b>\$ 11.15</b>

*\*Cost is anticipated to be shared by Utah County, NRCS, Strawberry High Line Canal Company, UDOT, or other parties. See breakdown in CFP Section.*

*<sup>†</sup>Top width of channel*

## FUTURE GROWTH PROJECT DESCRIPTIONS

Project specific descriptions are provided below, with potential alternatives identified. Unless specified otherwise, regional detention ponds are designed to capture excess surface flows beyond the 25-year storm that the commercial, industrial, mixed-use, or high-density developments upstream of them are required to retain onsite. Debris basins are designed to capture the full design event, whichever governed (100-year, 25-year burned, debris flow)

### F1 NORTHWEST INDUSTRIAL REGIONAL POND #1 3.1 AC-FT

This pond is in the northwest section of the area anticipated to be annexed into the city in the future. It will capture excess runoff from the proposed industrial area. Providing such a facility promotes growth in the area by reducing the amount of land that the industrial developments must dedicate to the storage of water. If the specific proposed developments will have sufficient open area, and depending on the layout, this pond potentially could be incorporated into the site itself in an easement.

### F2 NORTHWEST INDUSTRIAL REGIONAL POND #2 6.7 AC-FT

This pond will capture excess runoff from the proposed industrial area. If the specific proposed developments will have sufficient open area, and depending on the layout, this pond potentially could be incorporated into the site itself in an easement. It could also be built in conjunction with the proposed Summit Ridge Irrigation Company Groundwater Aquifer Recharge Basins planned nearby.

### F3 RAILROAD CORRIDOR INDUSTRIAL REGIONAL POND #1 1.0 AC-FT

Located on the on the north side of Highway 6 where it crosses the railroad tracks, this pond will capture excess runoff from the proposed industrial area to the east, north of Highway 6. It could potentially be combined with the proposed F4 Regional Pond if final design shows this to be most cost-effective and efficient.

### F4 RAILROAD CORRIDOR INDUSTRIAL REGIONAL POND #2 3.1 AC-FT

Located on the on the south side of Highway 6 where it crosses the railroad tracks, this pond will capture excess runoff from the proposed industrial area to the south and to the east, south of Highway 6, but north of 14000 South. It could potentially be combined with the proposed F3 Regional Pond if final design shows this to be cost-effective and efficient.

### F5 RAILROAD CORRIDOR INDUSTRIAL REGIONAL POND #3 3.2 AC-FT

Located on the on the south side of 14000 South where it dead ends at the railroad tracks, this pond will capture excess runoff from the proposed industrial areas on the south side of 14000 South. It also includes the areas zoned for schools and open park space to the east, reducing the area on those parcels that must be reserved for water storage. If there proves to be sufficient area on the school and park properties to retain the full 100-year, and it is preferred that the full 100-yr storm be retained there, the size of this pond could be reduced by moving some of the planned storage to the aforementioned properties. This pond also could potentially be combined with the proposed F3 and F4 Regional Ponds utilizing conveyance piping if final design shows this to be cost-effective and efficient.

#### F6 SUMMIT CREEK RESERVOIR REGIONAL POND 8.4 AC-FT

This regional detention basin located on the ground currently owned by the Summit Creek Irrigation Company, and on the north side of the master planned roadway, would reduce the onsite storage requirements for the commercial, mixed use, and high density residential areas shown in the master plan. The areas served by this basin are bordered by Summit Ridge Parkway and the Freeway on the south, and Summit Creek's Reservoir and the agricultural zones along 14400 South on the North.

#### F7 SUMMIT RIDGE PARKWAY REGIONAL POND 11.0 AC-FT

Conceptually, this regional detention basin is design to be located in multiple ponds on either side of Summit Ridge Parkway, all connected together to make one pond. In effect, it creates a larger than typical "park strip" on either side of Summit Ridge. This will be an economic incentive for growth in the area in that commercial and other developments will not be required to provide the full 100-year retention onsite, and could enhance the aesthetics of the corridor. It would serve the commercial, mixed use, and industrial areas shown in the master plan located between Summit Ridge Parkway, I-15, and the railroad on the west. As an option, some of the water could be diverted to the F6 Regional Pond by means of an open swale or pipe to reduce the area required at this location, thought the F6 Regional Pond would have to increase in size accordingly. A quarter of the required property is assumed to be located on existing public right-of-way.

#### F8 SANTAQUIN CANYON OVERFLOW CHANNEL 400 CFS CHANNEL

This channel safely conveys the flows through the city coming from the overflow channel for the spillway of the Santaquin Canyon Debris Basin. It commences at the breached section of the existing overflow channel and carries flows all the way down to Summit Ridge Reservoir, where the flows are currently captured. The upper channel, from the existing channel down to the freeway, is assumed to be riprapped, and is estimated to be 3-feet deep, have a 10-foot wide bottom and 3:1 side slopes. The lower portion, running from "The Mona Road" (Frontage Road near current Chevron) to the reservoir, is assumed to be lined with turf reinforcement mat (TRM), is estimated to be 3-feet deep, have a 6-foot wide bottom, and 3:1 side slopes. The upper portion is considered the most critical, and if the project must be phased, it should be completed first.

It is recommended that the city investigate shared participation with both Utah County and NRCS, as both parties have interest and/or potential funding to assist in such an effort.

It may also be desirable to cover the channel, or allow stepped detention basins to be built within the channel itself to allow adjacent development to conserve water storage space on their sites, but those developments would be responsible for any cost above and beyond the basic proposed channel. The proposed designs would have to guarantee the full channel capacity under all circumstances.

#### F9 SANTAQUIN CANYON OVERFLOW CHANNEL – I-15 CROSSING 10'X4' CULVERT

This channel conveys flows beneath I-15 coming from the overflow channel for the spillway of the Santaquin Canyon Debris Basin. The flow currently would overwhelm the existing CMP culvert crossing beneath the freeway and would flow through beneath the underpass, spreading in an uncontrolled fashion downstream. The crossing is currently estimated as a 10'x4' Box Culvert.

It is recommended that the city investigate heavily shared participation with UDOT, Utah County, and the NRCS, as all parties have an interest and/or potential funding to assist in such an effort.

#### F10 WESTERN COMMERCIAL REGIONAL POND 3.0 AC-FT

This pond is located at the western extremity of the city. Much of the land is currently owned by the Utah Department of Natural Resources. It will capture excess runoff from the proposed commercial area. Providing such a facility promotes growth in the area by reducing the amount of land that the commercial developments must dedicate to the storage of water. Being located in an area master planned as open space helps save cost and improve aesthetics.

#### F11 SOUTH OFF-RAMP COMMERCIAL REGIONAL BASIN 0.5 AC-FT

This pond is located near the southern Santaquin off-ramp in an area anticipated to be annexed into the city in the future. It will capture excess runoff from the proposed commercial area. Much of the property master planned as commercial that it is proposed to serve is currently owned by UDOT, Utah County, and the Utah Department of Natural Resources, which may affect the timeline and feasibility of commercial growth in this area. A pipe, which conveys flows beneath the proposed F8 Santaquin Canyon overflow channel, is also included.

#### F12 SOUTH MOUNTAINS DEBRIS CONTROL STRUCTURE 2.4 AC-FT

This debris control structure will protect the commercial and residential areas and the freeway below. It is designed to retain the full 100-year runoff event. Any flow through outlet works will be limited to flow just sufficient to drain the structure in emergencies or prevent excessive retention time. If Project F8 (Santaquin Canyon Overflow Channel) were sized to handle the additional peak runoff, and if it were verified that the existing Santaquin Debris Basin overflow channel has sufficient capacity, this basin could possibly be eliminated and be replaced by a pair of debris racks or similar debris control structures that retain debris but allow the water to flow through.

#### F13 SOUTHEAST BENCH DEBRIS CONTROL STRUCTURE #1 AND DIVERSION CHANNEL 10.3 AC-FT

This debris control structure will protect projected residential and agricultural in the foothills to the southwest of Santaquin, which could be annexed in the future. It is designed to retain the full 100-year runoff event. Any flow through outlet works will be limited to flow just sufficient to drain the structure in emergencies or prevent excessive retention time. It is located on private property to avoid any complications with the Forest Service. It includes a conveyance channel to carry runoff and debris flows to the basin. If the Forest Service proves amenable to its installation, some cost could potentially be saved by locating on Forest Service property. If the pond can be excavated fully below ground, dam safety issues can also be avoided.

#### F14 SOUTHEAST BENCH DEBRIS CONTROL STRUCTURE #2 2.6 AC-FT

This debris control structure will protect projected residential and agricultural in the foothills to the southwest of Santaquin, which could be annexed in the future. It is located in planned open space. It is designed to retain the full 100-year runoff event. Any flow through outlet works will be limited to flow just sufficient to drain the structure in emergencies or prevent excessive retention time. It is located on private property to avoid any complications with the Forest Service. If the Forest Service proves amenable to its installation, some cost could potentially be saved by locating it on Forest Service property. If the pond can be excavated fully below ground, dam safety issues can also be avoided.

#### F15 SPRING LAKE DEBRIS CONTROL STRUCTURE #1 4.6 AC-FT

This debris control structure will protect existing and planned agricultural land in the foothills in the Spring Lake area of Santaquin, the Highline Canal, and the homes in the Spring Lake area. It is located in planned open space. It is designed to retain the full 100-year runoff event. Any flow through outlet works will be limited to flow just sufficient to drain the structure in emergencies or prevent excessive retention time. It is located on private property to avoid any complications with the Forest Service. If the Forest Service proves amenable to its installation, some cost could potentially be saved by locating it on Forest Service property. If the pond can be excavated fully below ground, dam safety issues can also be avoided.

As the Highline Canal and the Spring Lake area are large beneficiaries in this project, assistance and cosponsoring must be investigated. FEMA, NRCS and other funding sources must be researched and applied for as appropriate.

#### F16 SPRING LAKE DEBRIS CONTROL STRUCTURE #2 12.1 AC-FT

This debris control structure will protect existing and planned agricultural land in the foothills in the Spring Lake area of Santaquin, the Highline Canal, and the homes in the Spring Lake area. It is located in planned open space. It is designed to retain the full 100-year runoff event. Any flow through outlet works will be limited to flow just sufficient to drain the structure in emergencies or prevent excessive retention time. It is located on private property to avoid any complications with the Forest Service. If the Forest Service proves amenable to its installation, some cost could potentially be saved by locating it on Forest Service property. If the pond can be excavated fully below ground, dam safety issues can also be avoided.

As the Highline Canal and the Spring Lake area are large beneficiaries in this project, assistance and cosponsoring should be investigated. FEMA, NRCS and other funding sources should be researched and applied for as appropriate.

## CAPITAL FACILITIES PLAN

A city's storm drain system plays a vital role in protecting life and property. Planning for Santaquin's storm drainage system must consider major flooding that could occur from burned hillsides, as well as localized flooding that occurs from storm water runoff generated within the city. As Santaquin City continues to grow, the potential for localized flooding increases, requiring improvements to the storm drain system to accommodate new development. This Capital Facilities Plan outlines the projects that are required to address these existing deficiencies and the needs for future growth, including estimated costs and implementation schedules.

### DEFINITIONS

- ERU - Equivalent Residential Unit. Development contributes to storm water runoff based on the amount of impervious area it contains. For the purposes of this study, single family dwellings and multi-family residential units will each be considered one (1) ERU. ERU's for non-residential development including commercial, industrial, school and church buildings are based on their total impervious surface area with one (1) ERU equalling 2,700 square feet of impervious surface area.*
- Single Family Units = 1 ERU/home unit*
- Multi-Family Residential Units = 1 ERU/dwelling unit*
- Non-Residential Units = 1 ERU/2,700 SF of impervious area*
- cfs - Cubic feet per second (449 gallons per minute)*
- Ac-Ft - Acre foot (volume of water required to cover an acre of land to a depth of one foot)*
- Detention - Short term storage of runoff provided by a pond or similar facility. An outlet is provided that allows water to be released from the facility at a predetermined rate.*
- Retention - Long term storage of storm water provided by a pond or similar facility, but does not allow water to be discharged. Water will stay in a retention pond after a storm event until it either evaporates or soaks into the soil of the pond bottom.*



## GENERAL/CFP INTRODUCTION

Santaquin City is a rapidly growing community located at the south end of Utah County and lying at the base of the Wasatch Mountains. It is bounded on the east and southeast by Santaquin and Pole Canyons as well as several other small canyons and on the north and west by lowland agricultural and low mountains. The Strawberry-Highline canal is a prominent feature cutting across the northern edge of the city. The 2010 Census lists Santaquin City's population as 9,128. By 2040, it is expected to be just under 30,000 as discussed in the demographics section of this report.

Because of Santaquin's unique landscape, and lack of drainage outfall, the city must take a retain-on-site approach to drainage. There are, and will be, some regional retention basins. Retention facilities can be constructed above ground or below ground where feasible. This makes planning and optimizing usable land a challenging task.

This Capital Facilities Plan (CFP) analyzes Santaquin's future growth patterns and its projected infrastructure needs as it grows. Services addressed include only storm drain. The master plan portion of this document lays the foundation for creating this Capital Facilities Plan, which in turn will provide the necessary data to create the Impact Fee Facilities Plan. These plans will provide a prioritized project schedule for construction, cost estimates (in planning year dollars) and recommended impact fee levels based upon the projects required to accommodate new growth in the next six years.

---

### LEVEL OF SERVICE (LOS)

Level of service of Santaquin's current storm drain system is defined by the current city ordinances and construction standards. The following criteria establish conditions for which storm drainage facilities are currently designed.

- Design storm drains to keep water from ponding in streets and intersections during a 25-year storm event.
- Evaluate how storm drains will function during a 100-year storm event to identify areas where major flooding may occur.
- Require detention of other improvements that will limit discharge from a 100-year storm event.
- Control the 100-year flow rate and volume to prevent damage to property or life.

These same standards are applied to future conditions to create a master plan.

## DEMOGRAPHICS

The first step in updating any Capital Facilities Plan is to evaluate the city's current demographics and future population projections. The following section discusses Santaquin city's population, growth trends, and projected build-out population.

Santaquin City has developed a population projection table that shows the population and growth rate through the year 2060. The table is based on the assumption that the density of development will not be equal to the maximum allowable density. A different range in density would affect these numbers.

Year	Population	Growth Rate	Year	Population	Growth Rate
2010	9,128		2036	26,410	3.05%
2011	9,495	4.02%	2037	27,216	3.05%
2012	9,878	4.03%	2038	28,046	3.05%
2013	10,275	4.02%	2039	28,901	3.05%
2014	10,689	4.03%	2040	29,783	3.05%
2015	11,352	6.20%	2041	30,691	3.05%
2016	12,044	6.10%	2042	31,278	1.91%
2017	12,791	6.20%	2043	31,875	1.91%
2018	13,581	6.18%	2044	32,484	1.91%
2019	14,426	6.22%	2045	33,104	1.91%
2020	15,321	6.20%	2046	33,736	1.91%
2021	15,889	3.71%	2047	34,381	1.91%
2022	16,479	3.71%	2048	35,037	1.91%
2023	17,090	3.71%	2049	35,707	1.91%
2024	17,724	3.71%	2050	36,389	1.91%
2025	18,382	3.71%	2051	37,084	1.91%
2026	19,064	3.71%	2052	37,681	1.61%
2027	19,771	3.71%	2053	38,287	1.61%
2028	20,504	3.71%	2054	38,904	1.61%
2029	21,235	3.57%	2055	39,530	1.61%
2030	22,054	3.86%	2056	40,167	1.61%
2031	22,727	3.05%	2057	40,813	1.61%
2032	23,420	3.05%	2058	41,470	1.61%
2033	24,134	3.05%	2059	42,138	1.61%
2034	24,870	3.05%	2060	42,817	1.61%
2035	25,629	3.05%			

---

#### AVERAGE RESIDENTS PER HOUSEHOLD

For purposes of this Capital Facilities Plan (CFP), the current average household density was estimated at 3.9 residents per household.

---

#### CURRENT & FUTURE GROWTH

Forecasting the city's future needs relies heavily upon projecting future population trends and economic growth. We have used the following data sources to project the near future's growth rates for Santaquin:

- Currently adopted projection
- Utah Governor's Office of Management and Budget (Demographic and Economic Analysis)

One of the most significant areas of development currently under construction in Santaquin is Summit Ridge, which will contribute significant growth over the next decade in the residential zones. As such, an effort was made to evaluate what type of units would be built in the new developments.

#### FUTURE GROWTH TRENDS

In the past several years, the housing development market has far outpaced previous projections in Santaquin City. As such, the population growth has arrived more quickly than anticipated. Developments on the north and west side, such as Summit Ridge, are responsible for the majority of Santaquin's current growth. Figure 9 illustrates the estimated population growth projections.

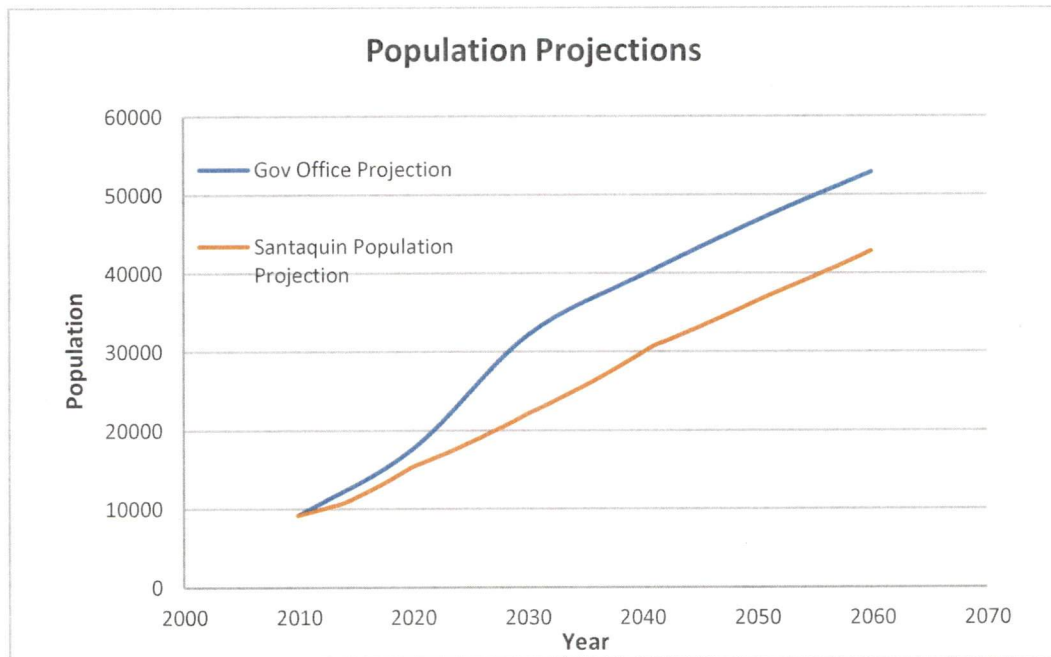

**Figure 9. Projected Population Growth**

The build-out number of ERUs is based on the number of residential units or a specified amount of impervious surface for commercial and industrial areas. The density of ERUs/acres are calculated as 1 ERU per residential home, or 13.71 ERUs per acre of non-residential development. The value of 13.71 ERUs is based on the assumption that 85% of the development is impervious, and that 2,700 square feet of impervious area is equivalent to 1 ERU. ( $0.85 \times 43,560sf \div 2,700sf = 13.71$ )

**Table 15. Build-Out Storm Drain ERU Projections**

Santaquin City Build-Out Storm Drain ERU Projections					
Land Use Classification	Area (acres)	Density (units/acre)	Total Units	ERUs per Unit or Acre*	Total ERUs (rounded)
Agricultural	2,945	0	0	0	0
Commercial	576	1	576	13.7	7,891
Industrial	690	1	690	13.7	9,454
Very Low Residential (A2)	856	1	856	1	856
Mixed-Use Residential (RM)	123	8	982	1	982
Medium Residential (R1)	1,293	4	5,173	1	5,173
Low Residential (R1A)	998	2	1,996	1	1,996
Multi-family Residential (R2)	742	8	5,936	1	5,936
Mixed-Use Residential (RM)	174	8	1,392	1	1,392
Parks and Open Space	739	0	0		0
Natural Open Space	2,398	0	0		0
Projected Build-Out ERUs					33,680

#### EXISTING FACILITIES

The existing storm drain system is shown in the figures on pages 50-55. It consists of small collection systems that were installed to correct specific problems and/or with recent developments. Some additional facilities are required to correct existing deficiencies within Santaquin City as described below and shown on the maps on pages 69-71. Projects that address these deficiencies have not be included in impact fee calculations, but cost estimates have been prepared and are included.

#### EXISTING DEFICIENCIES

Existing deficiencies are listed in detail in the Existing Deficiencies section of this report and are summarized as follows:

<u>Number</u>	<u>Description</u>
Ex D 1.	330 West and 650 North Storm Drain System
Ex D 2.	Hillside Debris Basins
Ex D 3.	Southeast Bench (A) Storm Drain System and Retention Basin
Ex D 4.	Southeast Bench (B) Storm Drain System and Retention Basin
Ex D 5.	750 North Park Retention Basin
Ex D 6.	North 350 West Retention Basin
Ex D 7.	400 East and 400 South Improvements

- Ex D 8. 680 N and 560 W Retention
- Ex D 9. Town Center Drainage
- Ex D 10. Lambert and State Highway 198 Drainage Improvements
- Ex D 11. NRCS Channel

## FUTURE GROWTH FACILITIES

The facilities recommended to accommodate future growth are listed and shown on pages 75-83 of the Master Plan portion of this report. A list of the projects needed is repeated in the table below. These projects serve as the basis of the Impact Fee Facilities Plan.

**Table 16. Future Growth Project Costs**

No.	Description	Size	Cost (million \$)
F1	Northwest Industrial Regional Pond #1	3.1 ac-ft	\$ 0.38
F2	Northwest Industrial Regional Pond #2	6.7 ac-ft	\$ 0.65
F3	Railroad Corridor Industrial Regional Pond #1	1.0 ac-ft	\$ 0.12
F4	Railroad Corridor Industrial Regional Pond #2	3.1 ac-ft	\$ 0.33
F5	Railroad Corridor Industrial Regional Pond #3	3.2 ac-ft	\$ 0.34
F6	Summit Creek Reservoir Regional Pond	8.4 ac-ft	\$ 0.93
F7	Summit Ridge Parkway Regional Pond	11.0 ac-ft	\$ 1.04
F8	Santaquin Canyon Overflow Channel	24 to 33 ft <sup>†</sup>	\$ 2.25*
F9	Santaquin Canyon Overflow Channel – I-15 Crossing	10'x4' Culvert	\$ 0.95*
F10	Western Commercial Regional Pond	3.0 ac-ft	\$ 0.37
F11	South Off-Ramp Commercial Regional Basin	0.5 ac-ft	\$ 0.17
F12	South Mountains Debris Control Structure	2.4 ac-ft	\$ 0.35
F13	Southeast Bench Debris Control Structure #1 and Diversion Channel	10.3 ac-ft	\$ 1.09
F14	Southeast Bench Debris Control Structure #2	2.6 ac-ft	\$ 0.35
F15	Spring Lake Debris Control Structure #1	4.6 ac-ft	\$ 0.55*
F16	Spring Lake Debris Control Structure #2	12.1 ac-ft	\$ 1.40*
	<b>Grand Total</b>		<b>\$ 11.15</b>

*\*Cost is anticipated to be shared by Utah County, NRCS, UDOT, or others. See breakdown in Table 17*

*<sup>†</sup>Top width of channel*

## CAPITAL FACILITIES PLAN PROJECTS MAP

A map of all projects in the capital facilities plan is included on the following page.

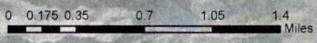
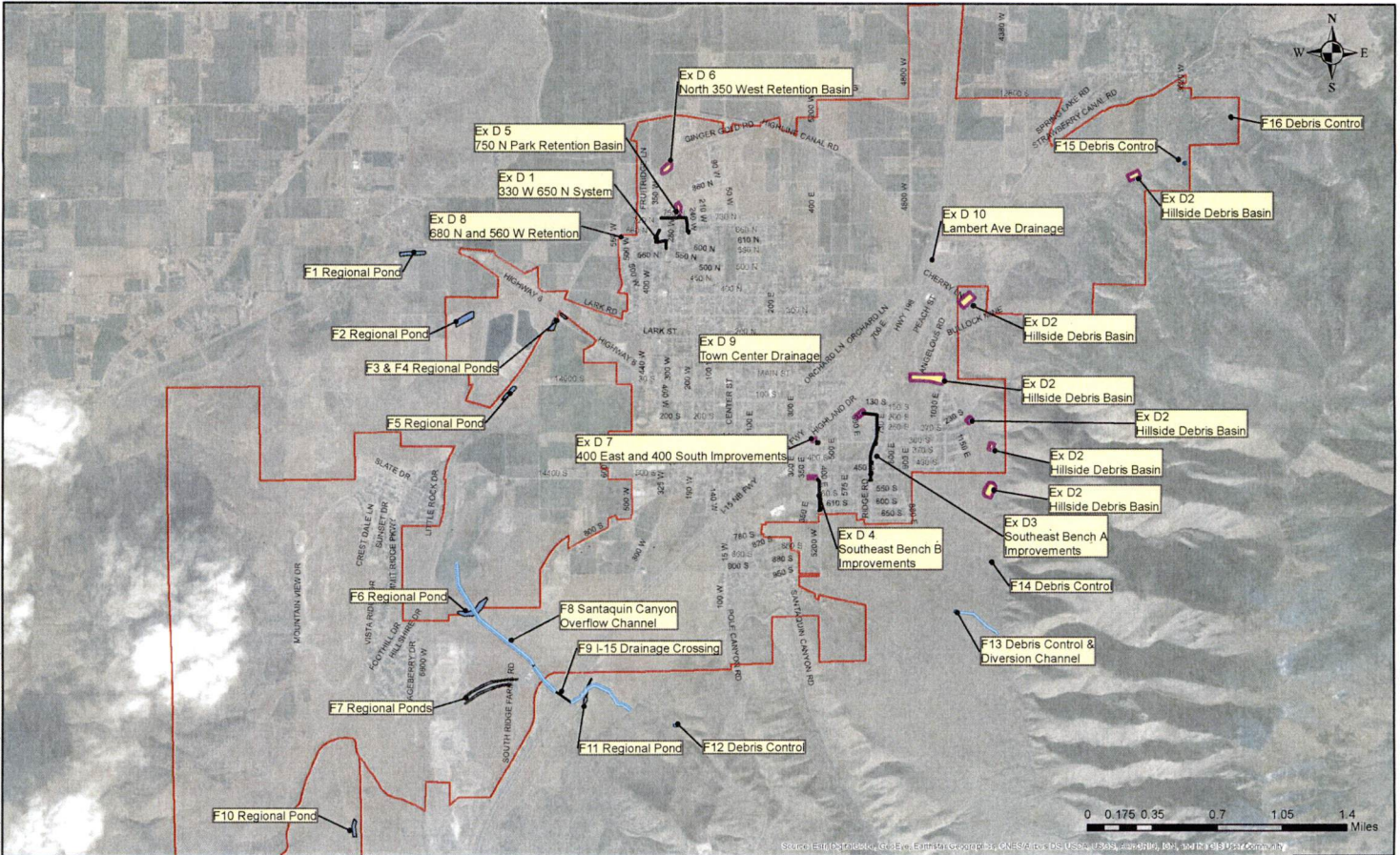

Source: Esri, DigitalGlobe, GeoEye, Earthstar (Google), CNES/Airbus DS, USDA, USGS, AeroGRID, IGN, and the GIS User Community



**Capital Improvements Plan**  
**Storm Drain Master Plan**

6/7/2018

SCHEDULE

The CFP indicates which improvements are needed in the future, and provides a planning level cost estimate for each improvement (see Appendix B). Recommended improvements to the storm drain system are separated into the following categories: short range (1-6 years) and medium range (7-10 years), and long range (time undetermined). Table 17 summarizes the improvement projects, anticipated costs and projected funding sources.

The Town Center Drainage Improvements are divided into two options, Option A being drainage only improvements, and Option B being full roadway improvements. In addition, a do nothing option for the Town Center may be considered. Separate totals are provided depending on which option is selected. In this schedule, 20 of the 56 blocks are recommended to occur during the next six years, 18 would occur 7 to 10 years out, and the remaining 18 would occur after the 10-year planning window.

**Table 17. Storm Drain Capital Facilities Estimates**

	<b>Project</b>	<b>Estimate (Millions)</b>	<b>Funding Source</b>	<b>Year</b>
<b>1-6 Year Improvements (2019 to 2024)</b>				
Ex D 1	330 West and 650 North Storm Drain System	\$0.43	city	2019
Ex D 2	Hillside Debris Basins	\$12.3	\$9.5 M (NRCS – Design and Construction) \$2.8M (Santaquin—Property)	2019
Ex D 3	Southeast Bench (A) Storm Drain System and Retention Basin	\$0.90	city	2020
Ex D 4	Southeast Bench (B) Storm Drain System and Retention Basin	\$0.52	city	2021
Ex D 5	750 North Park Retention Basin	\$0.32	city	2022
Ex D 6	North 350 West Retention Basin	\$0.22	city	2024
Ex D9a	Town Center Drainage (drainage only improvements for 20 blocks) – <b>Options A</b>	\$4.0	city	2019-2024
Ex D9b	Town Center Drainage (full improvements for 20 blocks) – <b>Option B</b>	\$10.40	city	2019-2024
F8	Santaquin Canyon Overflow Channel	\$2.25	20% Impact Fees/65% NRCS/15% county	2021
F6	Summit Creek Reservoir Regional Pond	\$0.93	Impact Fees	2023
<b>Subtotal (with Town Center Option A)</b>		\$22.91		



Project		Estimate (Millions)	Funding Source	Year
<b>Subtotal (with Town Center Option B)</b>		\$29.31		
<b>7-10 Year Improvements (2025-2028)</b>				
Ex D 7	400 East and 400 South Improvements	\$0.16	city	2025
Ex D 8	680 N and 560 W Retention	\$0.12	city	2026
Ex D9a	Town Center Drainage (drainage only improvements for 18 blocks) – <b>Option A</b>	\$3.6	city	2025-2028
Ex D9b	Town Center Drainage (full improvements for 18 blocks) – <b>Option B</b>	\$9.4	city	2025-2028
Ex D 10	Lambert and State Highway 198 Drainage Improvements	\$0.04	city	2026
Ex D 11	NRCS Channel	\$0.0	county & NRCS	2027
F9	Santaquin Canyon Overflow Channel – I-15 Crossing	\$0.95	15% Impact Fees, 10% UDOT, 65% NRCS, 10% county	2025
<b>Subtotal (with Town Center Option A)</b>		\$4.87		
<b>Subtotal (with Town Center Option B)</b>		\$10.67		
<b>Long-Term Improvements</b>				
Ex D9a	Town Center Drainage (drainage only improvements for 18 blocks) – <b>Option A</b>	\$3.6	city	2025-2028
Ex D9b	Town Center Drainage (full improvements for 18 blocks) – <b>Option B</b>	\$9.4	city	2025-2028
F15	Spring Lake Debris Control Structure #1	\$0.55	33% Impact Fees/33% Highline Canal/ 33% Spring Lake (county)	NA
F16	Spring Lake Debris Control Structure #2	\$1.40	33% Impact Fees/33% Highline Canal/ 33% Spring Lake (County)	NA
F3	Railroad Corridor Industrial Regional Pond #1	\$0.12	Impact Fees	NA
F4	Railroad Corridor Industrial Regional Pond #2	\$0.33	Impact Fees	NA

Project		Estimate (Millions)	Funding Source	Year
F5	Railroad Corridor Industrial Regional Pond #3	\$0.35	Impact Fees	NA
F13	Southeast Bench Debris Control Structure #1 and Diversion Channel	\$1.09	Impact Fees	NA
F14	Southeast Bench Debris Control Structure #2	\$0.37	Impact Fees	NA
F11	South Off-Ramp Commercial Regional Basin	\$0.17	Impact Fees	NA
F12	South Mountains Debris Control Structure	\$0.35	Impact Fees	NA
F2	Northwest Industrial Regional Pond #2	\$0.65	Impact Fees	NA
F1	Northwest Industrial Regional Pond #1	\$0.38	Impact Fees	NA
F10	Western Commercial Regional Pond	\$0.37	Impact Fees	NA
<b>Subtotal (with Town Center Option A)</b>		\$9.73		
<b>Subtotal (with Town Center Option B)</b>		\$15.53		

*Data supporting budgetary storm drain cost estimates are included in the Appendix B.*

## IMPACT FEE FACILITIES PLAN

Impact fees provide communities with a legal means to obtain funds from new developments to finance the construction of infrastructure improvements that are needed to serve new growth. State law requires that impact fees be used only for improvements made necessary by new growth and not for existing deficiencies. According to the current state law, impact fees must use a six-year planning window to encumber the funds. Therefore, the impact fee calculations in this chapter consider only those projects that are projected to be constructed or encumbered within the next six years.

This plan outlines the projects that address future needs and will be used to calculate impact fees to be assessed on new developments. Any projects, which serve both existing needs and future needs, were analyzed to determine the portion of the cost that can be attributed to future growth and is to be included in the impact fee analysis.

---

### PROPORTIONATE SHARE

In determining projects costs eligible for impact fees, this document attempts to assign only the proportionate share of costs for future improvements that are due to future growth. It is evident that the cost of existing infrastructure in the majority of cases cannot be assigned a legitimate dollar value per resident since very little information is available as to how existing infrastructure was financed, what share the city financed, what agency constructed the improvement, and how much the improvements actually cost. Therefore, in accordance with the Utah Impact Fees Act, Title 11, Chapter 36a, every effort has been made to evaluate impact fees considering only those costs that are attributable to future growth. As such, a current Level of Service (LOS) has been defined for each element and master planning performed to maintain the existing standards. Impact fees have been evaluated assigning the costs associated with maintaining these standards to future development as Santaquin City grows.

---

### ELIGIBLE IMPACT FEE PROJECTS

The projects from the Capital Facilities Plan eligible for impact fees are summarized in Table 18. Specific project descriptions are provided in the “Needs for Future Growth” section of the SDMP.

**Table 18. Impact Fee Eligible Projects**

Project	2018 Eligible Expenses (Millions)	Projected Constr. Year	Constr. Year Estimate (Millions)
1-6 Years			
Ex D 2 Hillside Debris Basins	\$0.91 out of \$12.3	2019	\$0.91
F7 Summit Ridge Parkway Regional Pond	\$1.04	2019	\$1.08
F8 Santaquin Canyon Overflow Channel	\$0.45 out of \$2.25	2021	\$0.45
F6 Summit Creek Reservoir Regional Pond	\$0.93	2023	\$.13
<b>Total</b>	<b>\$2.57</b>		

## PROJECT ELIGIBILITY

The justification for impact fee eligibility for each of the above named projects is provided below.

### PROJECT EX D 2 – HILLSIDE DEBRIS BASINS

The flood and debris flow protection provided by these basins serves not only the existing development, but all future development as well. The construction of these projects may also allow cost-effective development of land that is currently prohibitively costly to develop. The costs of mitigation of events if not protected would be borne by the city as a whole. As these benefits serve some future development, the costs of such are eligible for inclusion in the impact fees.

### PROJECT F7 – SUMMIT RIDGE PARKWAY REGIONAL POND

This pond is proposed exclusively to serve potential future development, and as a means of relieving such development of the necessity of storing the full 100-year event on their own property.

### PROJECT F8 – SANTAQUIN CANYON OVERFLOW CHANNEL

This channel is intended to protect lands for the purpose of enabling future development. As such, the costs of this project are eligible for inclusion in the impact fees.

### PROJECT F6 – SUMMIT CREEK RESERVOIR REGIONAL POND

This pond is proposed exclusively to serve potential future development, and as a means of relieving such development of the necessity of storing the full 100-year event on their own property.

## PROJECTS WITH COST SHARING – COST BREAKDOWN

Several of the eligible projects listed in Table 18 are projected to be partially funded by other entities. Table 18 shows the portion of the total cost that must be covered by impact fees compared to the overall project cost. Descriptions of the funding sources for those projects that do have outside funding are provided below. Full project descriptions are provided in the Recommended Future Growth Projects section of the Storm Drain Master Plan.

The assumed cost participation by other agencies must be initiated and negotiated by the City, and the distributions are not guaranteed.

### PROJECT F8 - SANTAQUIN CANYON OVERFLOW CHANNEL

Project F8 assumes that the NRCS will participate with a 65% cost share in the form of grants, as has been common practice when upgrading facilities they originally designed that address flooding and safety. Since Utah County has jurisdiction over the canal, a 15% cost share has been assumed on their part, leaving 20% for the city. Utah Dam Safety may also be willing to participate in this project. Further coordination is recommended as this project is prepared for study or analysis.

## PROJECT EX D 2, HILLSIDE DEBRIS BASINS

Project Ex D 2 has been developed as a measure to address existing deficiencies, but it also protects properties which have yet to develop, and a portion of the cost is therefore eligible for impact fees. The cost of mitigating and disasters would be borne by all the residents of Santaquin, so they are a benefit to all residents and developers. The city proposal for funding of these projects from the NRCS included a 95% cost share by the NRCS for construction, with the remaining 5% being born by City. However, NRCS has stated that it will cover 100% of design and construction costs. Land acquisition costs are the City's responsibility and are estimated at \$2.8 million. The region protected by the basins is 33% undeveloped by area. Therefore 33% of the City's share in the project will be included as impact fee eligible expenses (\$0.9 million).

## Impact Fee Facilities Plan Certification Page

I certify that the attached impact fee facilities plan:

1. Includes only the costs of public facilities that are:

- a. allowed under the Impact Fees Act; and
- b. actually incurred; or
- c. projected to be incurred or encumbered within six years after the day on which each impact fee is paid;
- d. existing deficiencies documented as such and not meant for inclusion in impact analysis.

2. Does not include:

- a. costs of operation and maintenance of public facilities;
- b. costs for qualifying public facilities that will raise the level of service for the facilities, through impact fees, above the level of service that is supported by existing residents;
- c. an expense for overhead, unless the expense is calculated pursuant to a methodology that is consistent with generally accepted cost accounting practices and the methodological standards set forth by the federal Office of Management and Budget for federal grant reimbursement; and

3. Complies in each and every relevant respect with the Impact Fees Act

---

Jacob O'Bryant, P.E.

## IMPACT FEE ANALYSIS

Throughout this study, existing conditions have been analyzed as well as future needs due to development and growth. This section defines the financial impact that new development will have on Santaquin City in the next six years and recommends impact fees for each element analyzed in this study. These fees will be needed to maintain the existing level of service throughout the city. It does not include existing deficiencies. Projects are considered part of an overall storm drain system and the cost of improvements is shared throughout the city.

Impact fees charged for new development are based on the number of ERUs in the proposed development. Budgetary costs were evaluated in future dollars (proposed project planning year dollars), assuming an inflation rate of 6% per year. They consider and assume current and future projects can be financed by 10-year or 5-year loans with a 4% interest rate.

The Storm Drain Capital Facilities Plan (CFP) identifies project required to mitigate existing deficiencies as well as those needed to address future growth. Impact fees may only be collected for projects needed to address future growth and that are projected to be incurred or encumbered within six years of the time the impact fee is collected.

The impact fees cannot be used for operation and maintenance of public facilities, or to raise the level of service that is currently supported by existing residents.

---

### CASE-BY-CASE IMPACT FEE ADJUSTMENTS

Santaquin City understands that future developments will each have individualized impacts on the city and therefore, in order to impose impact fees fairly, the city may adjust standard impact fees to meet unusual circumstances as allowed by State Code. Adjustments may be made for any of a number of reasons including studies or data submitted by the developer, land dedicated as a condition of development, and/or system improvements constructed by a new development.

### IMPACT FEE CALCULATIONS

The impact fee is proposed and calculated in two parts: Base Impact Fee and Regional Pond Impact Fee. The combination of the two adds to the overall impact fee. The impact fees are based on anticipated growth the needed projects to accommodate that growth. The growth estimation is explained in detail in the following section.

---

### ERU PROJECTIONS

In order to calculate the revenue available from impact each year it is necessary to project yearly ERU growth. The number of ERUs for residential development was calculated from the projected yearly population growth utilizing the average residents per household referred to in the Capital Facilities Plan of 3.9. ERUs for non-residential development was determined as a percentage of residential growth.

The percentage of non-residential properties was calculated based on the February 2017 land use GIS data provided by Santaquin City. Using spatial data analysis routines the number of properties noted as developed residential lots were counted, with each property being counted as one ERU. The area of non-residential lots was evaluated and the number of ERUs was calculated based on the using the area based calculation shown in the Future Growth Trends section of the CFP. Land uses that generally would not be subject to impact fees or would not contribute a significant quantity of ERUs were not included. The accuracy of this method of determining the ERU ratio is deemed sufficiently accurate for projection calculations

The current ratio of residential to non-residential ERUs was determined to be 3,980 Residential ERUs to 1,097 Commercial ERUs, or 3.63. Therefore, ERUs are related to the population growth according to the following formula:

$$ERU = \frac{PG}{3.9} \left( 1 + \frac{1}{3.63} \right)$$

Where PG = Population growth in a given year

Using these formulas, the growth in ERUs per year are shown in Table 19 below.

**Table 19. ERU Annual Projections**

Year	Population	Population Change	Growth Rate	Residential ERU Growth	Commercial ERU Growth	Total ERU Growth
2018	13,581	-	6.18%			
2019	14,426	845	6.22%	217	60	277
2020	15,321	895	6.20%	229	63	292
2021	15,889	568	3.71%	146	40	186
2022	16,479	590	3.71%	151	42	193
2023	17,090	611	3.71%	157	43	200
2024	17,724	634	3.71%	163	45	208
2025	18,382	658	3.71%	169	47	216
2026	19,064	682	3.71%	175	48	223
2027	19,771	707	3.71%	181	50	231
2028	20,504	733	3.71%	188	52	240
2029	21,235	731	3.57%	187	52	239



**IMPACT FEE CALCULATIONS**

The following table shows the calculations used for the base impact fee. Although Santaquin is not required to enact impact fees exactly as outlined in this study, it may not impose fees higher than what is recommended.

**Table 20. Base Impact Fee Calculation**

<b>Storm Drain Impact Fee Analysis</b>							
<b>Proposed Impact Fee</b>		\$468.00			<b>Interest Rate</b>		4.00%
<b>Fiscal Year Ending</b>			<b>Impact Fee Analysis and Collection</b>	<b>F8 Santaquin Canyon Overflow Channel (20% of Total) (financed for 10 years)</b>			
	<b>New ERU's*</b>	<b>Impact Fee Revenue</b>	<b>\$30,000.00</b>	<b>\$490,000.00</b>	<b>Year End Net Income</b>	<b>Cumulative Balance*</b>	
2018							
2019	277	\$129,636.00	-\$5,000.00		\$124,636.00	\$124,636.00	
2020	292	\$136,656.00	-\$5,000.00		\$131,656.00	\$256,292.00	
2021	186	\$87,048.00	-\$5,000.00	-\$60,412.56	\$21,635.44	\$277,927.44	
2022	193	\$90,324.00	-\$5,000.00	-\$60,412.56	\$24,911.44	\$302,838.87	
2023	200	\$93,600.00	-\$5,000.00	-\$60,412.56	\$28,187.44	\$331,026.31	
2024	208	\$97,344.00	-\$5,000.00	-\$60,412.56	\$31,931.44	\$362,957.75	
2025				-\$60,412.56	-\$60,412.56	\$302,545.19	
2026				-\$60,412.56	-\$60,412.56	\$242,132.62	
2027				-\$60,412.56	-\$60,412.56	\$181,720.06	
2028				-\$60,412.56	-\$60,412.56	\$121,307.50	
2029				-\$60,412.56	-\$60,412.56	\$60,894.94	
2030				-\$60,412.56	-\$60,412.56	\$482.37	
2031					\$0.00	\$482.37	
2032					\$0.00	\$482.37	
2033							
2034							
Totals	1356	\$634,608.00	\$30,000.00	\$604,125.63			
<b>Portion of Impact Fee</b>			\$22.14	\$445.86			
<b>Total Revenue:</b>		\$634,608.00			<b>Total Payments:</b>	<b>\$634,125.63</b>	
					<b>Construction and Impact Fee Management Costs:</b>	<b>\$520,000.00</b>	
					<b>Interest Payments:</b>	<b>\$114,125.63</b>	

\*Notes: 1) Project costs are in future dollars (assuming 4% ir  
2) Initial balance is assumed to be \$0  
3) ERU's begin at start of 2019

---

## REGIONAL POND IMPACT FEE

Since the proposed regional ponds will serve development that will likely not completely occur within 6 years, current development should only pay its proportionate share of these projects.

In order to calculate the Regional Pond Impact Fee for the ponds that are anticipated to be built within the timeframe of this plan, the cost of each pond was divided by the projected number of ERUs in the area it serves. An average of the cost per ERU was then taken and is recommended as the Regional Pond Fee. Since dense commercial, industrial, and mixed-use developments are generally required to maintain 15% open space, it was assumed that 85% of the contributing areas were impervious. In accordance with the Definitions section of the CFP, ERUs were calculated as one ERU per 2700 square feet of impervious area. A Summary of these calculations is provided below in Table 21.

**Table 21. Regional Pond Impact Fee Calculation**

Pond	Contributing Area (acre)	Contributing Area (SF)	Impervious Area (SF)	Total ERUs Served by Pond	Pond Cost (\$Millions)	Cost/ERU	
F6	285	12,414,600	10,552,410	3908.3	0.93	\$237.97	
F7	253	11,020,680	9,367,578	3469.5	1.04	\$299.80	
						Average \$/ERU	\$270*

\*Rounded

$$\text{Impervious Area} = \text{Contributing Area} \times 0.85 \qquad \text{ERU} = \frac{\text{Impervious Area}}{2700 \text{ square feet}}$$

---

## DEBRIS BASIN IMPACT FEE

The proposed debris basins on the east bench are considered a system improvement for the Santaquin City storm drain and flood control system. The debris basins are meant to be permanent structures with a lifespan of 100+ years. Although the impact fees may be collected during the next six years, the burden of paying for the debris basins should not be the sole responsibility of new ERUs during that six-year period, because future developments will benefit from the basins as well. The debris basin impact fees are calculated using the total build ERUs minus the existing ERUs. As indicated in Table 15, the build out number of ERUs is 33,680. The existing number of ERUs is 5,077. The total build out ERU minus the existing number of ERUs = 33,680-5,077 = 28,603. This is the number of ERUs over which the cost of the \$0.91M portion of the debris basins will be divided.

$$\text{Debris Basin Impact Fee} = \frac{\$0.91M}{28,603 \text{ ERUs}} = \$31.81/\text{ERU}$$

## RECOMMENDED IMPACT FEES

Impact Fees should be assessed as one per residence, and one per 2,700 square feet of impervious service on non-residential developments.

The recommended total impact fee is the combination of the Base Impact Fee, Regional Pond and Debris Basin Impact Fees. The recommended impact fees per ERU each year are as follows:  $\$468 + \$270 + \$32 = \$770$ .

The impact fee should be reevaluated every two years to determine whether any corrections should be made. The list of necessary projects should be reevaluated at regular intervals.

## CONCLUSION

### PLANNING

This master plan should be updated approximately every 5 years and as major changes develop within the city. This will enable the city to re-evaluate future needs based on then current conditions.

The city should maintain a complete inventory of the storm drain system. A complete storm drain system inventory will enable the city to schedule maintenance and replacement of storm drain infrastructure. A regularly updated system inventory will provide more detailed planning and modeling of the storm drain system.

The list of existing deficiencies should be updated regularly to assess completed projects, available budget, city needs, and other factors the city deems important. These projects can be combined with other public works projects to help save costs to the city.

### FUTURE DEVELOPMENT

Santaquin City has experienced considerable growth in recent years and it is expected that Santaquin will continue to experience significant growth in the immediate future. Because of this, growth within the city must be coordinated and managed so that any individual development does not negatively impact other areas of the city, or negatively impact the overall plans of the city. The city and developers must coordinate drainage projects to provide the best value to both the city and the developer. This master plan, and other city plans, must be consulted before any development is approved by the city. Proposed developments must be coordinated with needed city projects to ensure that the city's needs are met.

## APPENDICES

## APPENDIX A – EXISTING CONDITIONS WATERSHED MAPS

- Existing Conditions Watershed Maps



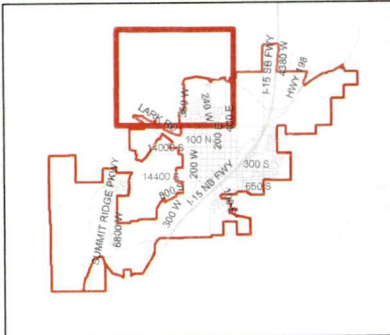
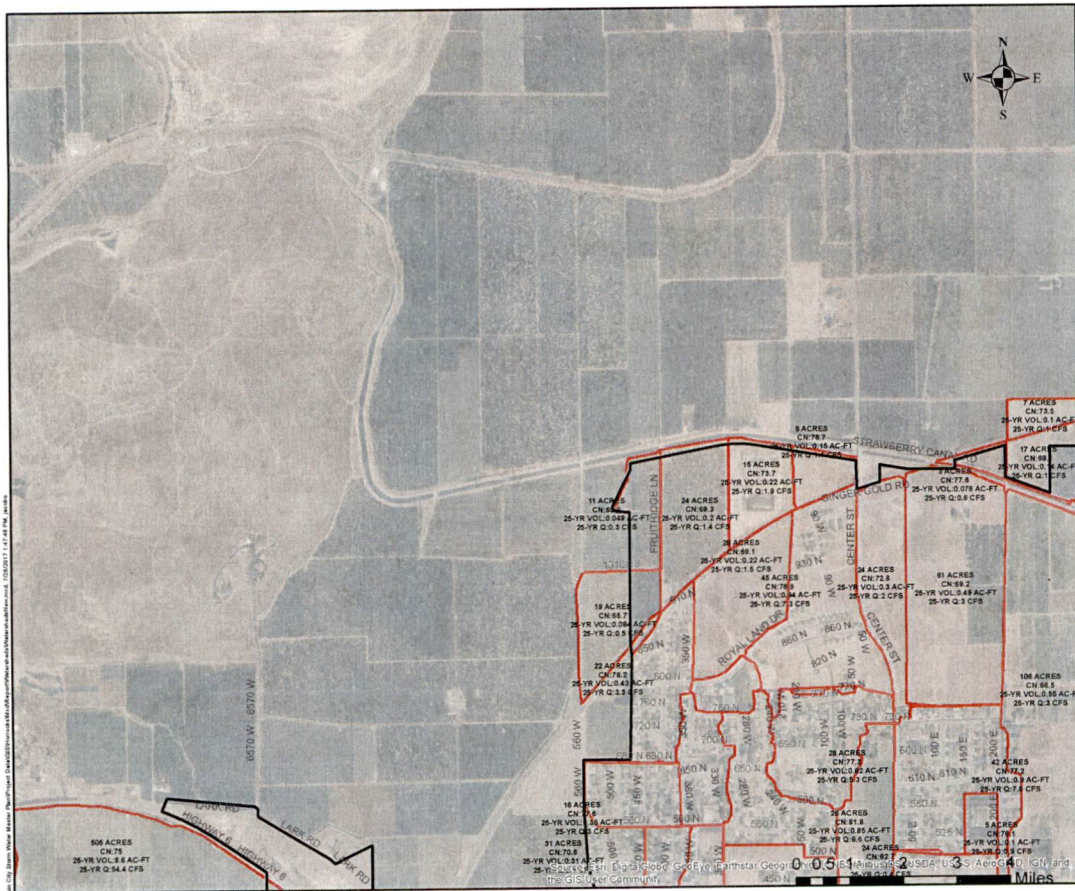

© 2017 ESRI. All rights reserved. This software is the property of Esri and is distributed under license from Esri. All other marks are the property of their respective owners.



Existing Watersheds

25-Year Storm

7/26/2017

Figure 1



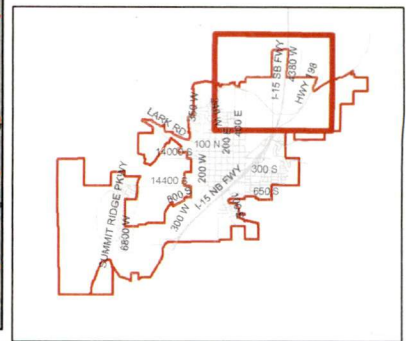
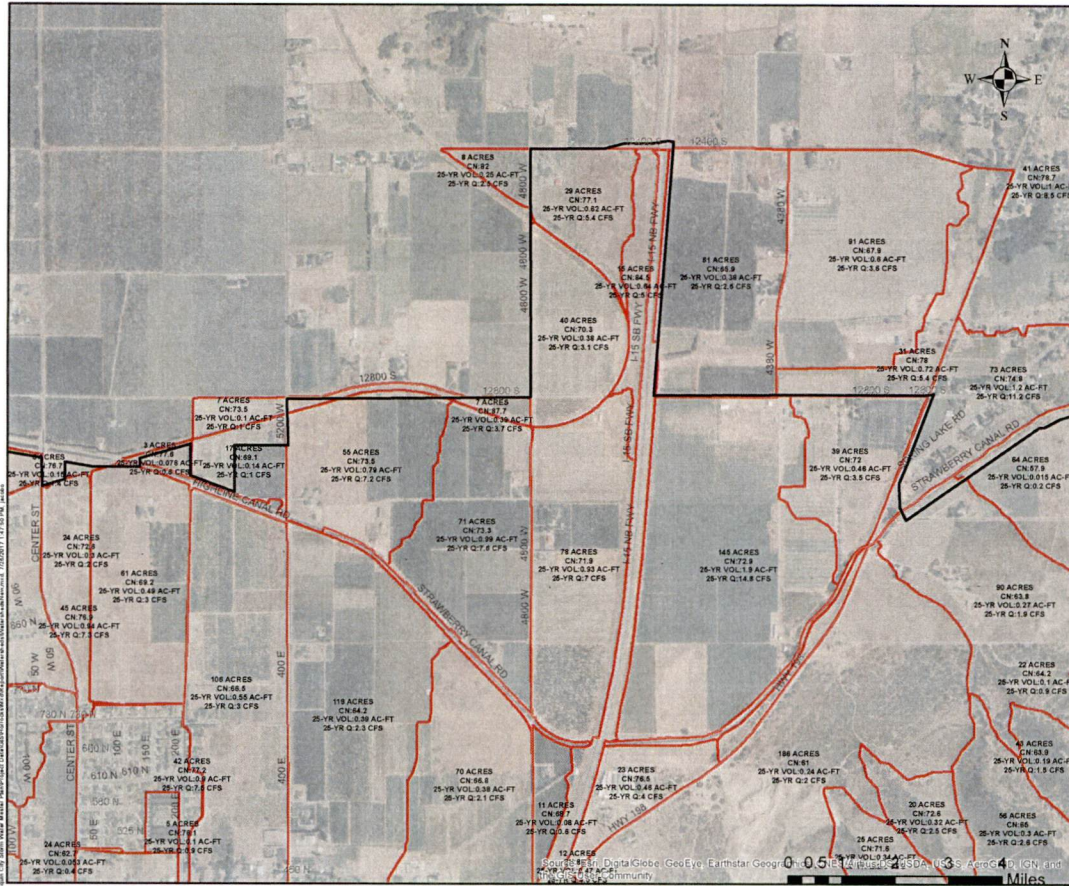

Existing Watersheds

25-Year Storm

7/26/2017

Figure 1

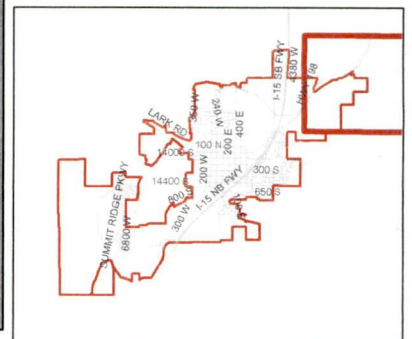
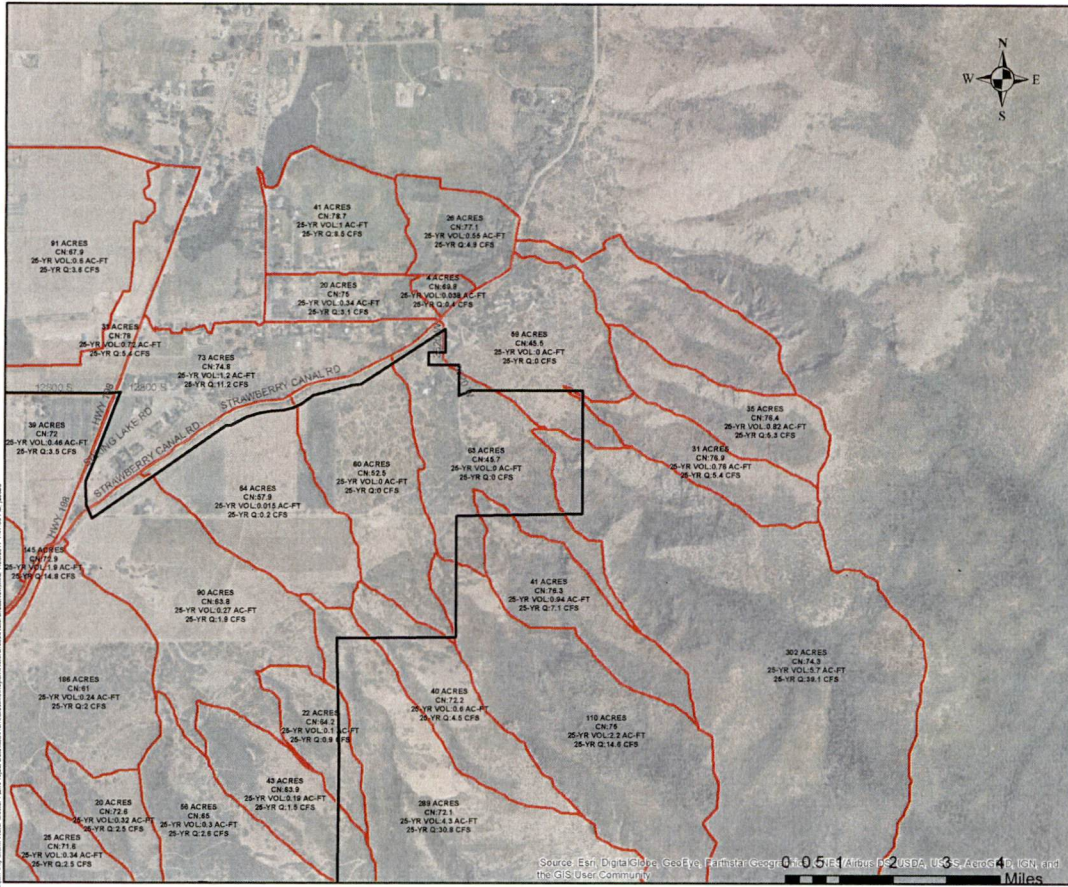

Existing Watersheds

25-Year Storm

7/26/2017

Figure 1

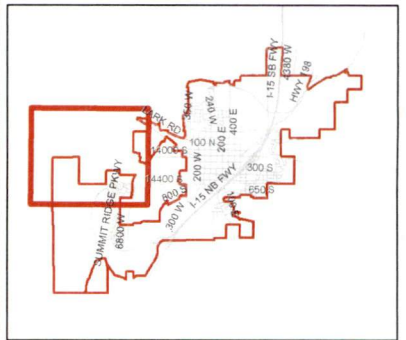
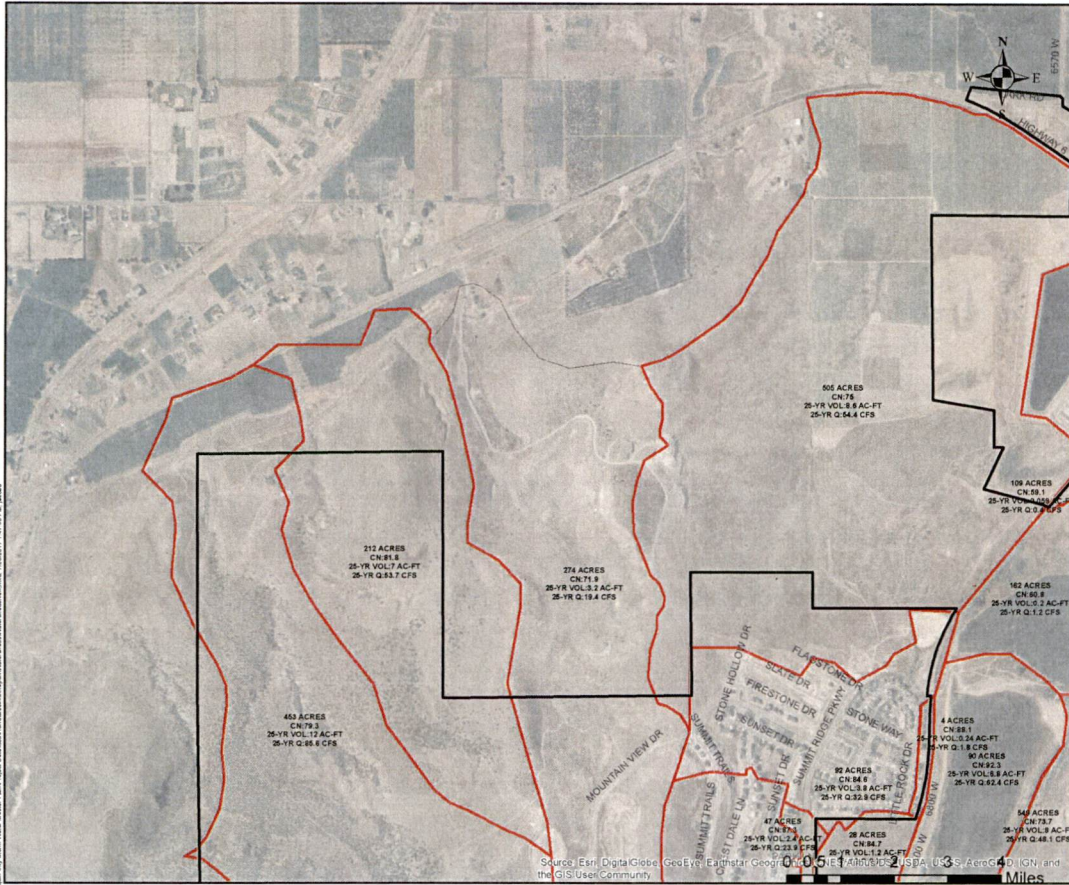

Existing Watersheds

25-Year Storm

7/26/2017

Figure 1

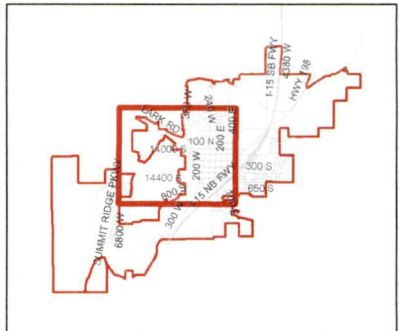
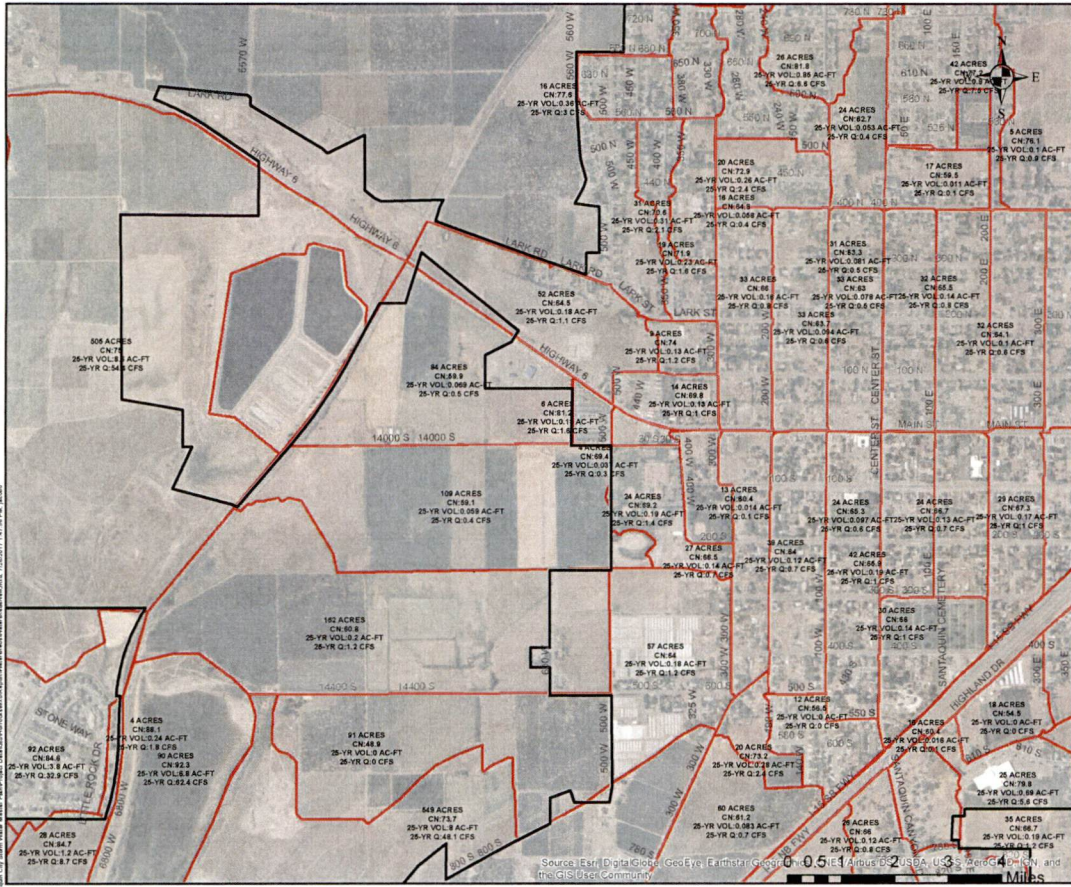

Existing Watersheds  
25-Year Storm

7/26/2017  
Figure 1

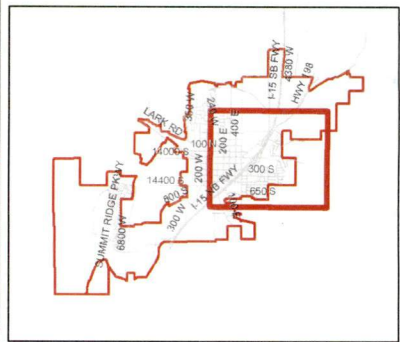
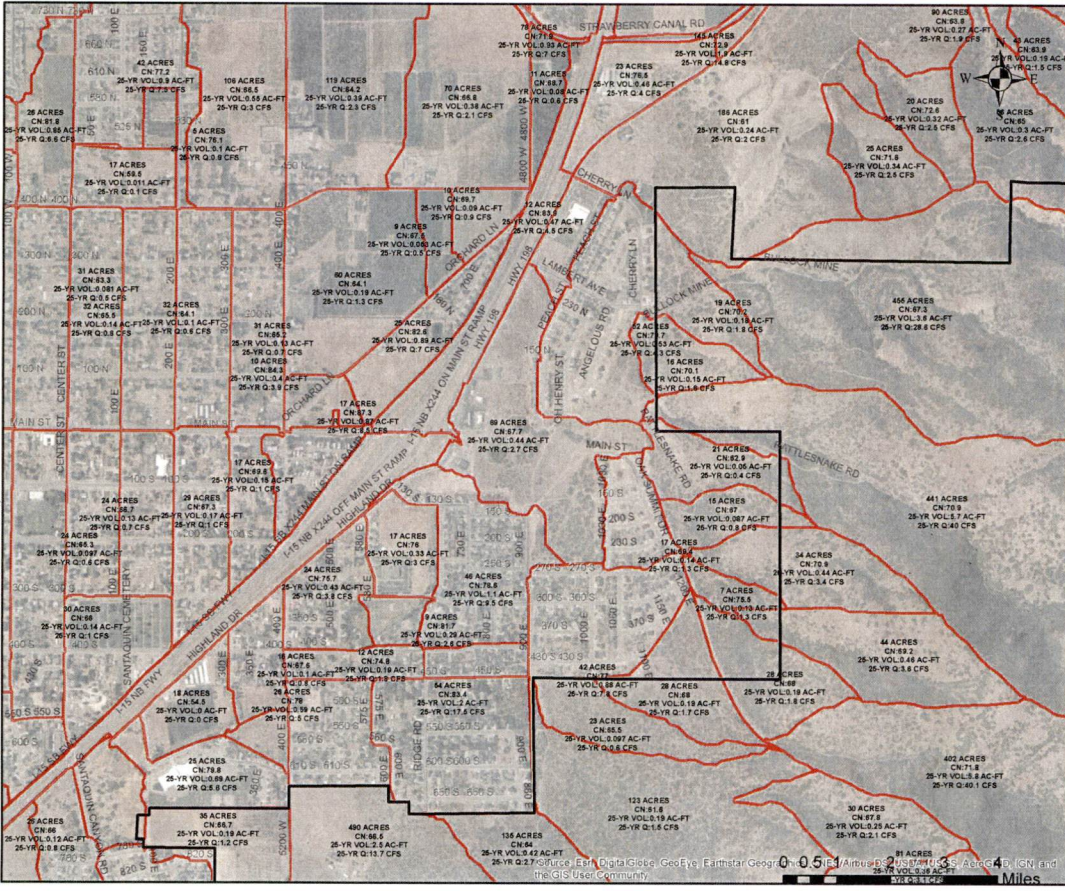

Existing Watersheds

25-Year Storm

7/26/2017

Figure 1

Source: Esri, Data Globe, GeoEye, Earthstar Geographics, CNR/Airphoto, USDA/GIA, AeroGRID, IGN, and the GIS User Community

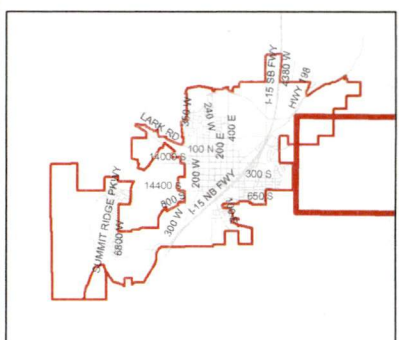
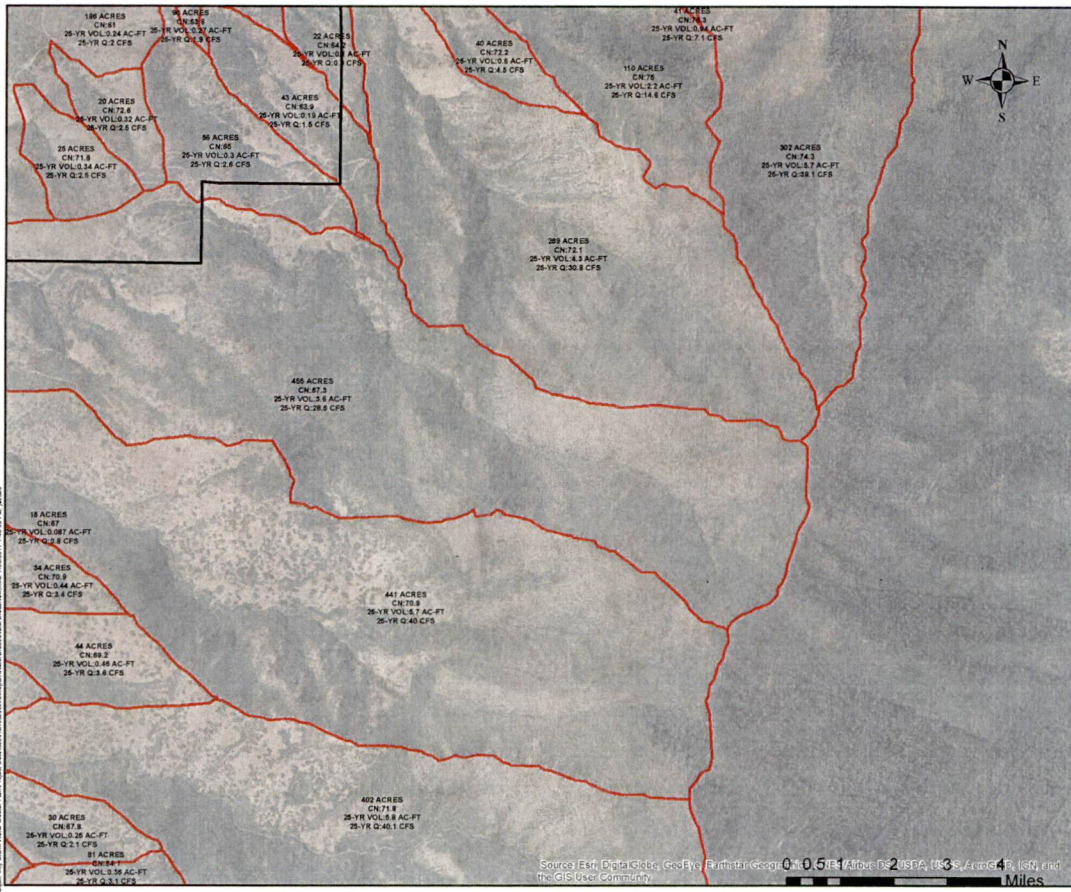

0:027818P3-113-112-110  
 Copyright © 2017 Esri. All rights reserved. This is a private, unpublished Esri product.



Existing Watersheds  
 25-Year Storm

7/26/2017  
 Figure 1

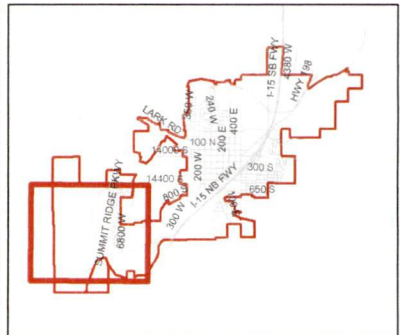
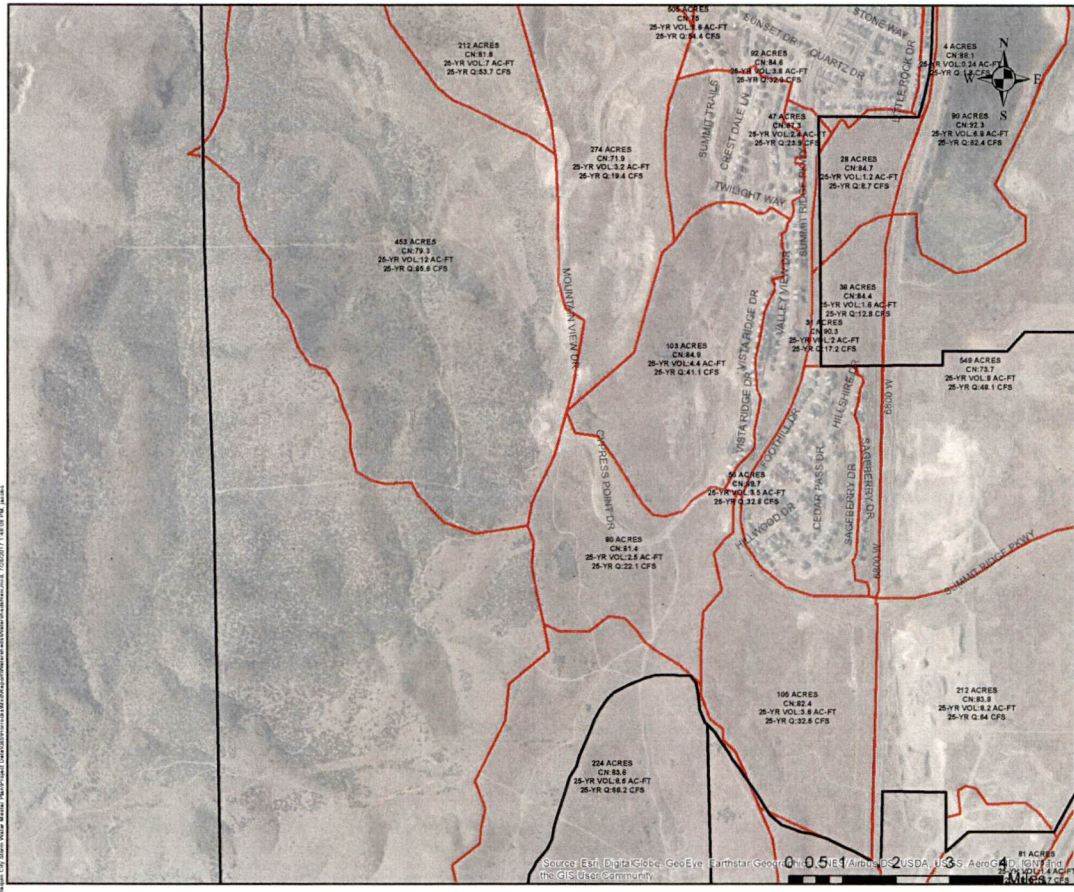

Existing Watersheds  
25-Year Storm

7/26/2017

Figure 1

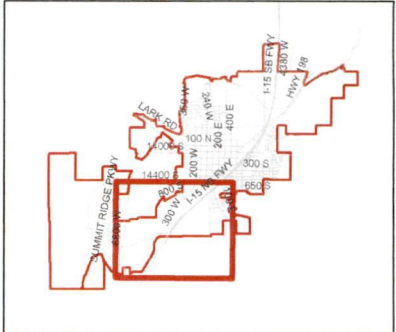
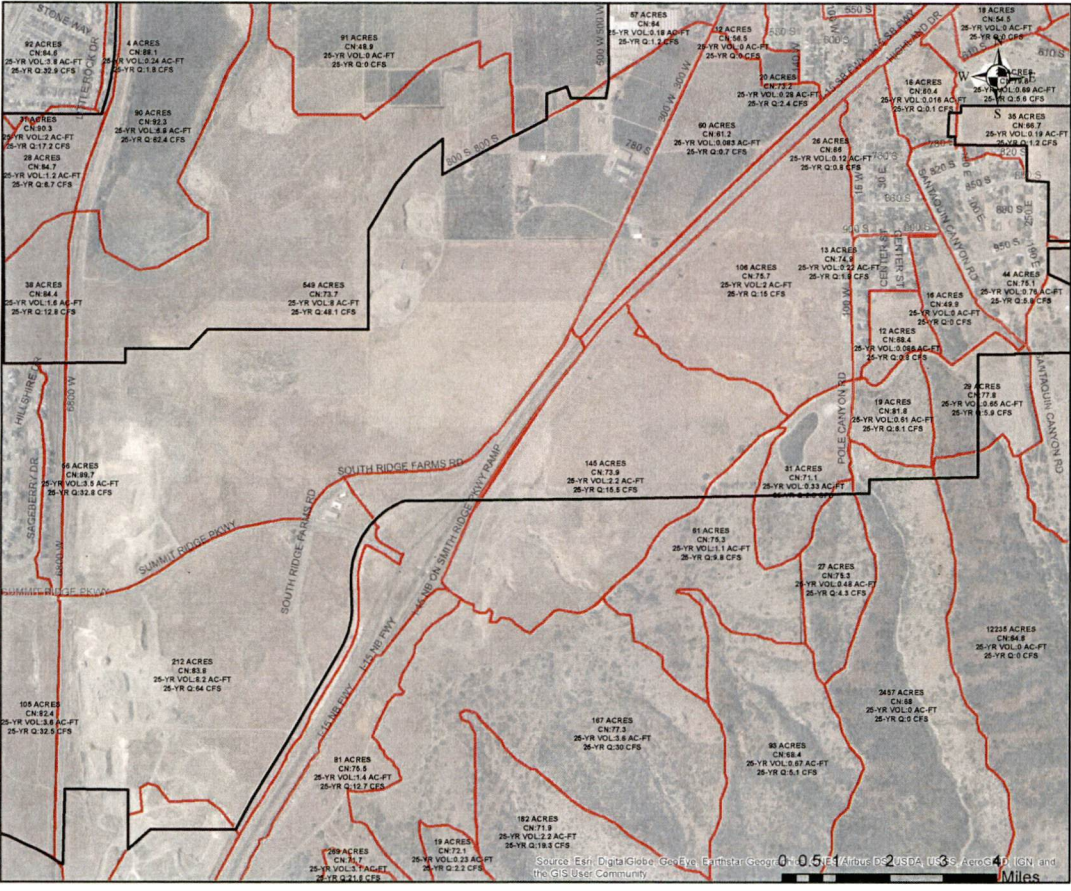

Existing Watersheds

25-Year Storm

7/25/2017

Figure 1

Source: Esri, DigitalGlobe, GeoEye, Earthstar Geographics, CNR/Air Force, DigitalGlobe, GeoEye, IGN, AerGRID, Airbus, USDA, USGS, AeroGRID, IGN, and the GIS User Community



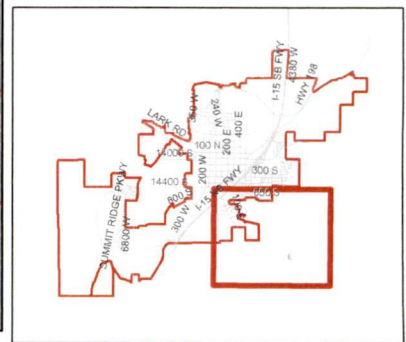
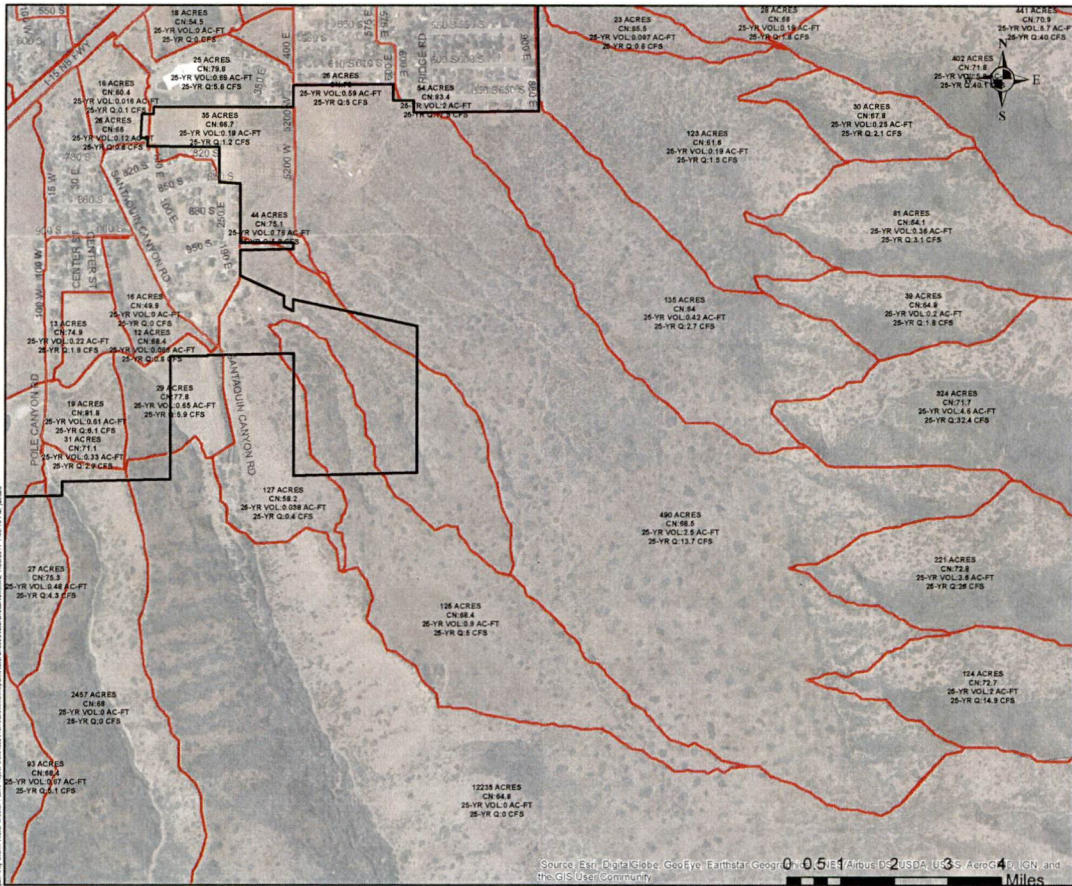

Existing Watersheds  
25-Year Storm

7/26/17  
Figure 1

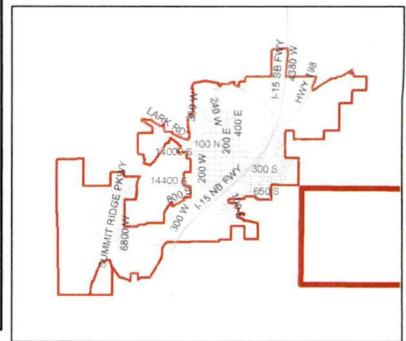
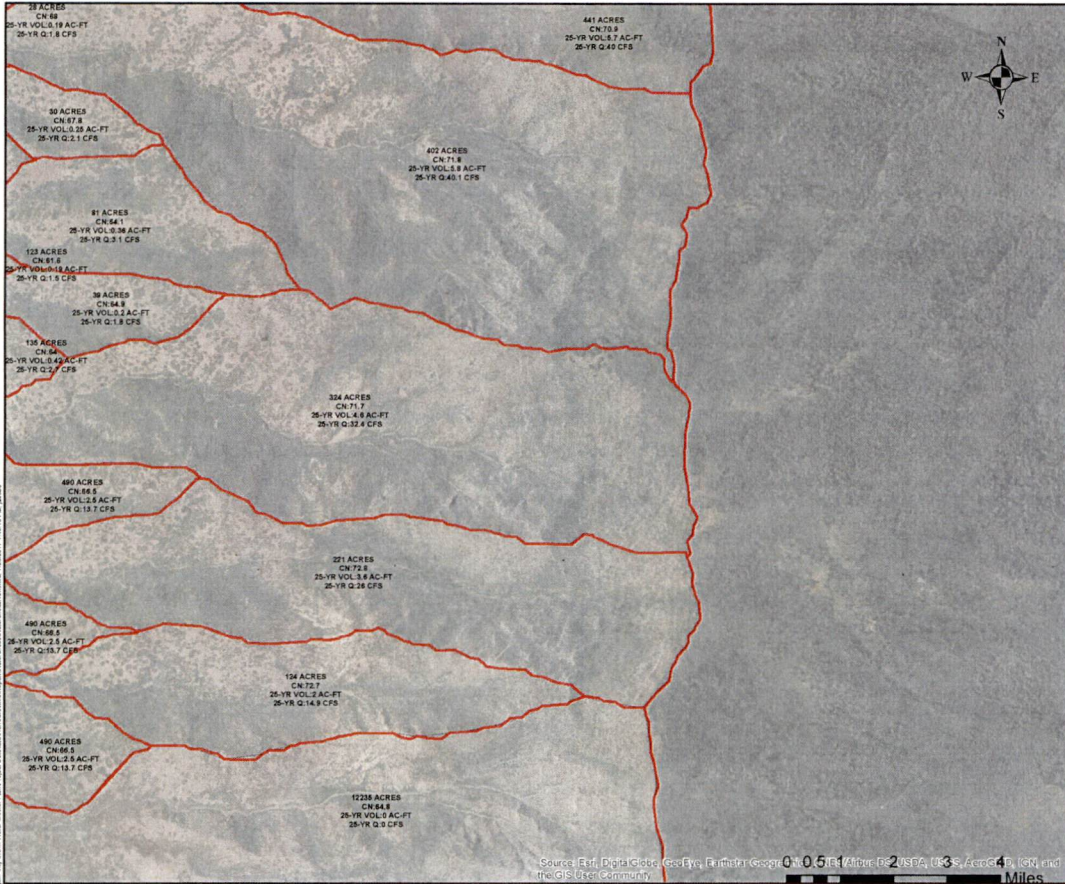

Existing Watersheds  
25-Year Storm

7/26/2017  
Figure 1

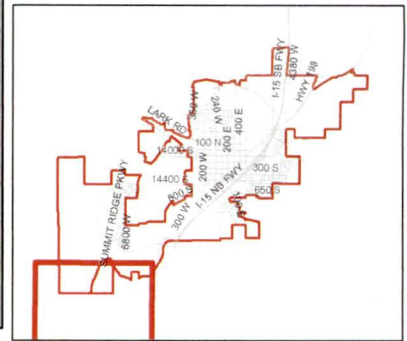
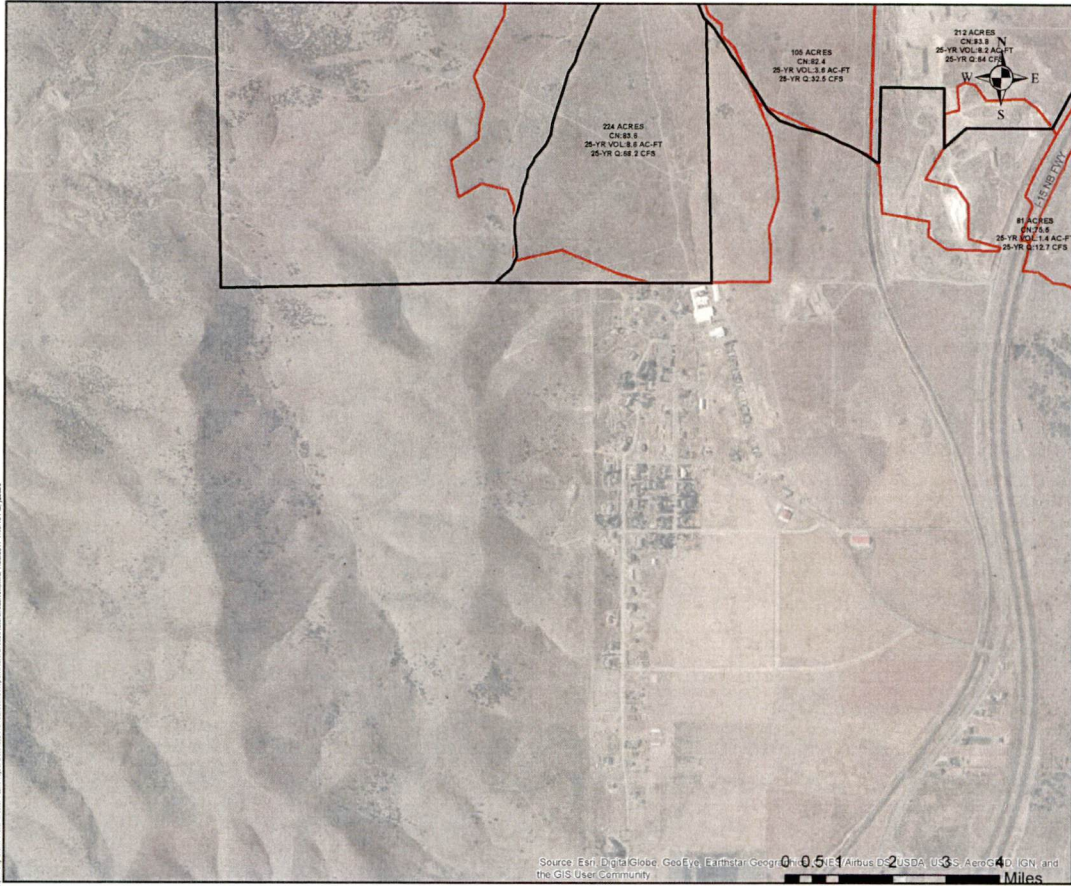

Source: Esri, DigitalGlobe, GeoEye, Earthstar Geographics, CNR Aero, IGN, and the GIS User Community. Scale: 0 - 0.5 Miles



Existing Watersheds  
25-Year Storm

7/26/2017

Figure 1

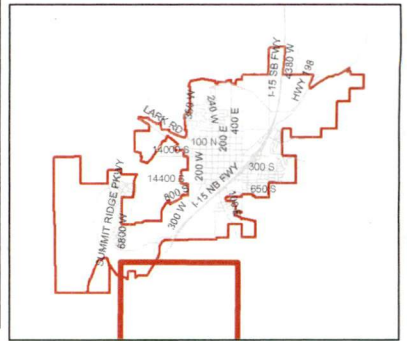
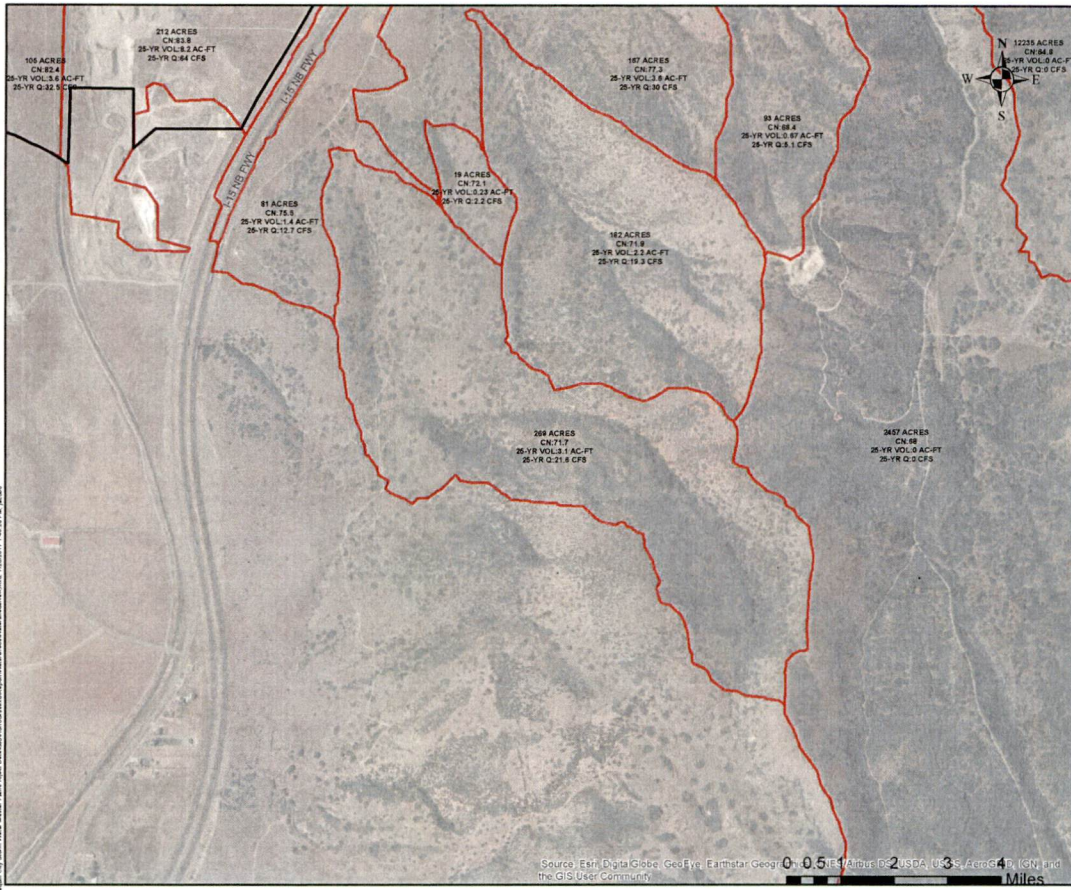

Existing Watersheds  
25-Year Storm

7/26/2017

Figure 1

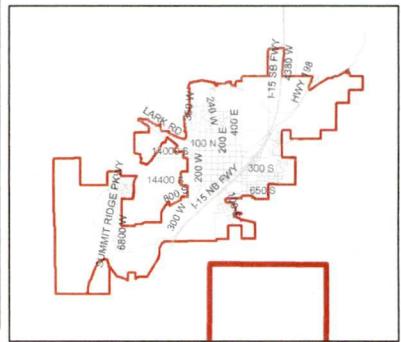

Existing Watersheds  
25-Year Storm

7/26/2017  
Figure 1

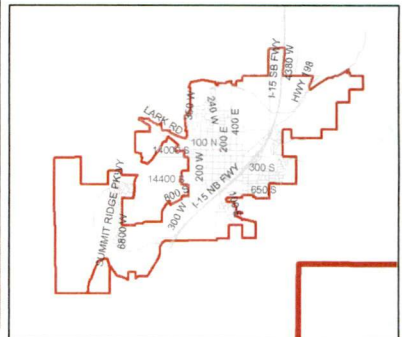
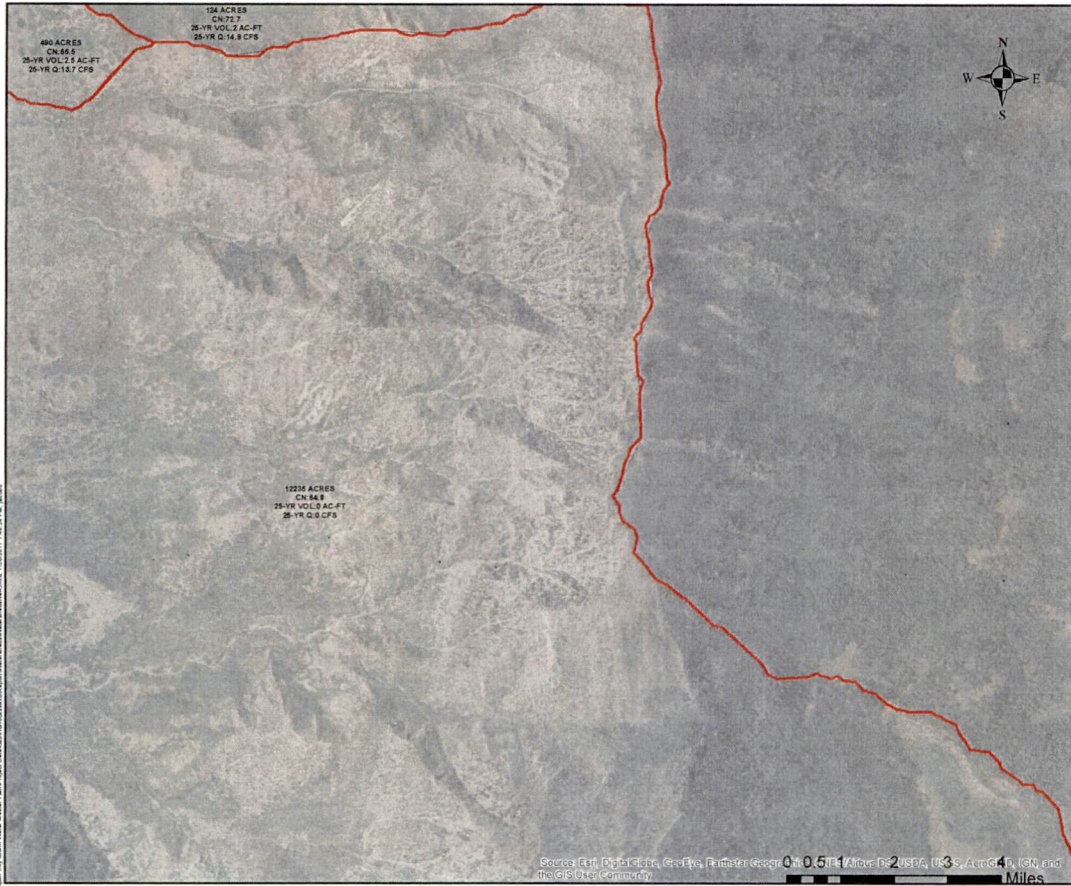

Existing Watersheds  
25-Year Storm

7/26/2017  
Figure 1

© 2017 ESRI. All rights reserved. This is a proprietary software and confidential information of the copyright holder. All other marks are the property of their respective owners.

APPENDIX B – EXISTING DEFICIENCIES COST ESTIMATES

#1

**Flooding at 330 W and 350 North**

Item	Description	Quantity	Units	Unit Cost	Cost
1	Mobilization	1	LS	----	\$14,887.53
2	15 Inch Storm Drain	1650	LF	\$65.00	\$107,250.00
3	18 Inch Storm Drain		LF	\$65.00	\$0.00
4	21 Inch Storm Drain	0	LF	\$65.00	\$0.00
5	24 Inch Storm Drain	0	LF	\$70.00	\$0.00
6	30 Inch Storm Drain		LF	\$75.00	\$0.00
7	36 Inch Storm Drain	0	LF	\$95.00	\$0.00
8	42 Inch Storm Drain	0	LF	\$125.00	\$0.00
9	48 Inch Storm Drain	0	LF	\$155.00	\$0.00
10	Basin Grading		CY	\$8.00	\$0.00
11	Manholes/Inlets/Structures	11	EA	\$3,500.00	\$38,500.00
12	Class "A" Road Repair	15262.5	SF	\$7.00	\$106,837.50
13	Class "D" Field Repair	0	SF	\$1.00	\$0.00
14	Imported Backfill	291.82	TON	\$18.00	\$5,252.81
15	Railroad and Canal Crossing	0	LS	\$108,000.00	\$0.00
16	State Road Crossing	0	LS	\$220,000.00	\$0.00
17	Traffic Control	1	LS	\$7,735.21	\$7,735.21
18	Utility Relocation (30% of pipe cost)	1	LS	\$32,175.00	\$32,175.00
<b>Sub Total (Construction)</b>					<b>\$312,638.04</b>
	Contingencies	20%			\$62,527.61
	Land		SF	\$5.00	\$0.00
	Right of Way	-	SF	\$2.50	\$0.00
<b>Total (Construction)</b>					<b>\$375,165.65</b>
	Design and Construction Engineering	15%			\$46,895.71
	Administration, Legal, and Bond Counsel	1%			\$3,126.38
<b>Total (Professional Services)</b>					<b>\$50,022.09</b>
<b>Grand Total</b>					<b>\$425,187.74</b>



**Basin 1 - Below Grade  
Hillside Debris Basins**

Item	Description	Quantity	Units	Unit Cost	Cost
1	Mobilization	1	LS	----	\$200,190.00
2	15 Inch Storm Drain	0	LF	\$55.00	\$0.00
3	18 Inch Storm Drain	0	LF	\$60.00	\$0.00
4	21 Inch Storm Drain	0	LF	\$65.00	\$0.00
5	24 Inch Storm Drain	0	LF	\$70.00	\$0.00
6	30 Inch Storm Drain	300	LF	\$75.00	\$22,500.00
7	36 Inch Storm Drain		LF	\$95.00	\$0.00
8	42 Inch Storm Drain	0	LF	\$125.00	\$0.00
9	48 Inch Storm Drain	0	LF	\$155.00	\$0.00
10	Spillway Cut	9,087	CY	\$8.00	\$72,696.00
11	Spillway Structure and Riprap	1	EA	\$45,000.00	\$45,000.00
11	Outlet works	1	EA	\$35,000.00	\$35,000.00
12	Excavation (cut)	217,813	CY	\$8.00	\$1,742,504.00
13	Embankment (fill)	55	CY	\$0.00	\$0.00
14	Sediment Basin Additional Cut	0	CY	\$0.00	\$0.00
15	Liner/internal Cutoff Earthwork	0	CY	\$8.00	\$0.00
16	Manholes/Inlets/Structures	1	EA	\$8,000.00	\$8,000.00
17	Toe Drain	1	LS	\$55,000.00	\$55,000.00
18	Class "A" Road Repair	0	SF	\$6.00	\$0.00
19	Class "D" Field Repair	-	SF	\$0.25	\$0.00
20	Revegetation	21.2	Acres	\$1,000.00	\$21,200.00
21	Imported Fill	0	CY	\$10.00	\$0.00
22	Railroad and Canal Crossing	0	LS	\$108,000.00	\$0.00
23	State Road Crossing	0	LS	\$220,000.00	\$0.00
24	Traffic Control	0	LS	\$675.00	\$0.00
25	Utility Relocation (20% of pipe cost)	0	LS	\$4,500.00	\$0.00
Sub Total (Construction)					\$2,202,090.00
Contingencies		20%			\$440,418.00
Land		462,000	SF	\$2.00	\$924,000.00
Right of Way		-	SF	\$1.00	\$0.00
Total (Construction)					\$3,566,508.00
Environmental		0%			\$0.00
Design and Construction Engineering					\$440,418.00
Administration, Legal, and Bond Counsel					\$22,020.90
Total (Professional Services)					\$462,438.90
<b>Grand Total</b>					<b>\$4,028,946.90</b>

**Basin 3A - Below Grade  
Hillside Debris Basins**

Item	Description	Quantity	Units	Unit Cost	Cost
1	Mobilization	1	LS	----	\$43,191.90
2	15 Inch Storm Drain	0	LF	\$55.00	\$0.00
3	18 Inch Storm Drain	0	LF	\$60.00	\$0.00
4	21 Inch Storm Drain	0	LF	\$65.00	\$0.00
5	24 Inch Storm Drain	0	LF	\$70.00	\$0.00
6	30 Inch Storm Drain	300	LF	\$75.00	\$22,500.00
7	36 Inch Storm Drain	0	LF	\$95.00	\$0.00
8	42 Inch Storm Drain	0	LF	\$125.00	\$0.00
9	48 Inch Storm Drain	0	LF	\$155.00	\$0.00
10	Trench Earthwork	0	LF	\$0.00	\$0.00
11	Spillway	1	EA	\$35,000.00	\$35,000.00
12	Outlet works	1	EA	\$20,000.00	\$20,000.00
13	Excavation (cut)	39836	CY	\$ 8.00	\$318,688.00
14	Embankment (fill)	0	CY	\$0.00	\$0.00
15	Imported Fill	0	CY	\$9.00	\$0.00
16	Cutoff Excavation and Backfill	0	CY	\$10.00	\$0.00
17	Sediment Basin Additional Cut	0	CY	\$5.00	\$0.00
18	Toe Drain	1	LS	\$25,000.00	\$25,000.00
19	Manholes/Inlets/Structures	1	EA	\$6,500.00	\$6,500.00
20	Class "A" Road Repair	0	SF	\$6.00	\$0.00
21	Class "D" Field Repair	3,150	SF	\$0.25	\$787.50
22	Revegetation	3.44	Acre	\$1,000.00	\$3,443.53
23	Railroad and Canal Crossing	0	LS	\$108,000.00	\$0.00
24	State Road Crossing	0	LS	\$220,000.00	\$0.00
25	Traffic Control	0	LS	\$675.00	\$0.00
	Utility Relocation (20% of pipe cost)	0	LS	\$4,500.00	\$0.00
Sub Total (Construction)					\$475,110.93
	Contingencies	20%			\$95,022.19
	Land	150,000	SF	\$2.00	\$300,000.00
	Right of Way	-	SF	\$1.00	\$0.00
Total (Construction)					\$870,133.11
	Environmental	0%			\$0.00
Design and Construction Engineering					\$95,022.19
Administration, Legal, and Bond Counsel					\$4,751.11
Total (Professional Services)					\$99,773.30
<b>Grand Total</b>					<b>\$969,906.41</b>

**Basin 4 - Above Grade, Single Watershed (4E)**

**Hillside Debris Basins**

Item	Description	Quantity	Units	Unit Cost	Cost
1	Mobilization	1	LS	----	\$80,308.99
2	15 Inch Storm Drain	0	LF	\$55.00	\$0.00
3	18 Inch Storm Drain	0	LF	\$60.00	\$0.00
4	21 Inch Storm Drain	0	LF	\$65.00	\$0.00
5	24 Inch Storm Drain	0	LF	\$70.00	\$0.00
6	30 Inch Storm Drain	200	LF	\$75.00	\$15,000.00
7	36 Inch Storm Drain	0	LF	\$95.00	\$0.00
8	42 Inch Storm Drain	0	LF	\$125.00	\$0.00
9	48 Inch Storm Drain		LF	\$155.00	\$0.00
10	60 Inch Pipe or Box Culvert (from upstream channel)	550	LF	\$250.00	\$137,500.00
11	Spillway Cut	8500	CY	\$6.00	\$51,000.00
12	Spillway Structure and Riprap	1	EA	\$50,000.00	\$50,000.00
13	Outlet works	1	EA	\$30,000.00	\$30,000.00
14	Excavation (cut)	67050	CY	\$6.00	\$402,300.00
15	Embankment (fill)	26600	CY	\$0.00	\$0.00
16	Imported Fill	0	CY	\$9.00	\$0.00
17	Cutoff Excavation and Fill	6028	CY	\$10.00	\$60,280.00
18	Sediment Basin Additional Cut	0	CY	\$5.00	\$0.00
19	Manholes/Inlets/Structures	1	EA	\$8,000.00	\$8,000.00
20	Toe Drain	1	EA	\$40,000.00	\$40,000.00
21	Class "A" Road Repair	0	SF	\$6.00	\$0.00
22	Class "D" Field Repair	-	SF	\$0.25	\$0.00
23	Revegetation	8	Acre	\$1,000.00	\$8,034.89
24	Imported Backfill	0	TON	\$12.00	\$0.00
25	Railroad and Canal Crossing	0	LS	\$108,000.00	\$0.00
26	State Road Crossing	0	LS	\$220,000.00	\$0.00
27	Traffic Control	1	LS	\$225.00	\$225.00
28	Utility Relocation (5% of pipe cost)	1	LS	\$750.00	\$750.00
Sub Total (Construction)					\$883,398.88
Contingencies					20%
Land					350,000 SF \$2.00 \$700,000.00
Right of Way					- SF \$1.00 \$0.00
Total (Construction)					\$1,760,078.66
Environmental					0% \$0.00
Design and Construction Engineering					20% \$176,679.78
Administration, Legal, and Bond Counsel					1% \$8,833.99
Total (Professional Services)					\$185,513.77
<b>Grand Total</b>					<b>\$1,945,592.43</b>

**Basin 5 (Below/hybrid)**

**Hillside Debris Basins**

Item	Description	Quantity	Units	Unit Cost	Cost
1	Mobilization	1	LS	----	\$193,505.00
2	15 Inch Storm Drain	0	LF	\$55.00	\$0.00
3	18 Inch Storm Drain	0	LF	\$60.00	\$0.00
4	21 Inch Storm Drain	0	LF	\$65.00	\$0.00
5	24 Inch Storm Drain	0	LF	\$70.00	\$0.00
6	30 Inch Storm Drain	200	LF	\$75.00	\$15,000.00
7	36 Inch Storm Drain	0	LF	\$95.00	\$0.00
8	42 Inch Storm Drain	0	LF	\$125.00	\$0.00
9	48 Inch Storm Drain	0	LF	\$155.00	\$0.00
10	Spillway and Channel Cut	23000	CY	\$8.00	\$184,000.00
11	Spillway Structure and Riprap	1	EA	\$50,000.00	\$50,000.00
12	Outlet works	1	EA	\$35,000.00	\$35,000.00
13	Excavation (cut)	197100	CY	\$8.00	\$1,576,800.00
14	Embankment (fill)	150	CY	\$0.00	\$0.00
15	Imported Fill		CY	\$9.00	\$0.00
16	Cutoff Excavation and Fill	1100	CY	\$20.00	\$22,000.00
17	Sediment Basin Additional Cut	0	CY	\$5.00	\$0.00
18	Manholes/Inlets/Structures	1	EA	\$6,500.00	\$6,500.00
19	Toe Drain	1	EA	\$45,000.00	\$45,000.00
20	Class "A" Road Repair	0	SF	\$6.00	\$0.00
21	Class "D" Field Repair	-	SF	\$0.25	\$0.00
22	Revegetation	-	Acre	\$1,000.00	\$0.00
22	Imported Backfill	0	TON	\$12.00	\$0.00
23	Railroad and Canal Crossing	0	LS	\$108,000.00	\$0.00
24	State Road Crossing	0	LS	\$220,000.00	\$0.00
25	Traffic Control	0	LS	\$450.00	\$0.00
26	Utility Relocation (5% of pipe cost)	1	LS	\$750.00	\$750.00
<b>Sub Total (Construction)</b>					<b>\$2,128,555.00</b>
	Contingencies	20%			\$425,711.00
	Land		SF	\$2.00	\$0.00
	Right of Way*	581,000	SF	\$0.10	\$58,100.00
<b>Total (Construction)</b>					<b>\$2,612,366.00</b>
	Environmental	0%			\$0.00
<b>Design and Construction Engineering</b>					<b>\$425,711.00</b>
<b>Administration, Legal, and Bond Counsel</b>					<b>\$21,285.55</b>
<b>Total (Professional Services)</b>					<b>\$446,996.55</b>
<b>Grand Total</b>					<b>\$3,059,362.55</b>

\*Administrative costs, based on land swap with the Forest Service

**Basin 6**

**Hillside Debris Basins**

Item	Description	Quantity	Units	Unit Cost	Cost
1	Mobilization	1	LS	----	\$95,868.72
2	15 Inch Storm Drain	0	LF	\$55.00	\$0.00
3	18 Inch Storm Drain	0	LF	\$60.00	\$0.00
4	21 Inch Storm Drain	0	LF	\$65.00	\$0.00
5	24 Inch Storm Drain	0	LF	\$70.00	\$0.00
6	30 Inch Storm Drain	350	LF	\$75.00	\$26,250.00
7	36 Inch Storm Drain	0	LF	\$95.00	\$0.00
8	42 Inch Storm Drain	0	LF	\$125.00	\$0.00
9	48 Inch Storm Drain	0	LF	\$155.00	\$0.00
10	Spillway Cut	12560	EA	\$6.00	\$75,360.00
11	Spillway Structure and Riprap	1	EA	\$50,000.00	\$50,000.00
12	Outlet works	1	EA	\$35,000.00	\$35,000.00
13	Excavation (cut)	89100	CY	\$6.00	\$534,600.00
14	Embankment (fill)	29091	CY	\$0.00	\$0.00
15	Imported Fill	6209	CY	\$10.00	\$62,088.40
16	Cutoff Excavation and Fill	6193	CY	\$10.00	\$61,930.00
17	Sediment Basin Additional Cut	0	CY	\$5.00	\$0.00
18	Toe Drain	1	EA	\$45,000.00	\$45,000.00
19	Manholes/Inlets/Structures	2	EA	\$8,000.00	\$16,000.00
20	Class "A" Road Repair	0	SF	\$6.00	\$0.00
21	Class "D" Field Repair	3,675	SF	\$0.25	\$918.75
22	Revegetation	9.04	Acre	\$1,000.00	\$9,045.00
22	Imported Backfill	3476	TON	\$12.00	\$41,707.56
23	Railroad and Canal Crossing	0	LS	\$108,000.00	\$0.00
24	State Road Crossing	0	LS	\$220,000.00	\$0.00
25	Traffic Control	1	LS	\$787.50	\$787.50
26	Utility Relocation (20% of pipe cost)	0	LS	\$5,250.00	\$0.00
<b>Sub Total (Construction)</b>					<b>\$1,054,555.93</b>
	Contingencies	20%			\$210,911.19
	Land	394,000	SF	\$2.00	\$788,000.00
	Right of Way	-	SF	\$1.00	\$0.00
<b>Total (Construction)</b>					<b>\$2,053,467.12</b>
	Environmental	0%			\$0.00
<b>Design and Construction Engineering</b>					<b>\$210,911.19</b>
<b>Administration, Legal, and Bond Counsel</b>					<b>\$10,545.56</b>
<b>Total (Professional Services)</b>					<b>\$221,456.75</b>
<b>Grand Total</b>					<b>\$2,274,923.86</b>

#3

**Inadequate Retention Volume Southeast Bench A**

Item	Description	Quantity	Units	Unit Cost	Cost
1	Mobilization	1	LS	----	\$23,898.04
2	15 Inch Storm Drain	0	LF	\$65.00	\$0.00
3	18 Inch Storm Drain	2200	LF	\$65.00	\$143,000.00
4	21 Inch Storm Drain	0	LF	\$65.00	\$0.00
5	24 Inch Storm Drain	0	LF	\$70.00	\$0.00
6	30 Inch Storm Drain	0	LF	\$75.00	\$0.00
7	36 Inch Storm Drain	0	LF	\$95.00	\$0.00
8	42 Inch Storm Drain	0	LF	\$125.00	\$0.00
9	48 Inch Storm Drain	0	LF	\$155.00	\$0.00
10	Basin Grading	5647	CY	\$8.00	\$45,173.33
11	Manholes/Inlets/Structures	23	EA	\$3,500.00	\$80,500.00
12	Class "A" Road Repair	20900	SF	\$7.00	\$146,300.00
13	Class "D" Field Repair	0	SF	\$1.00	\$0.00
14	Imported Backfill	411.99	TON	\$18.00	\$7,415.73
15	Railroad Crossing	0	LS	\$108,000.00	\$0.00
16	State Road Crossing	0	LS	\$220,000.00	\$0.00
17	Traffic Control	1	LS	\$12,671.67	\$12,671.67
18	Utility Relocation (30% of pipe cost)	1	LS	\$42,900.00	\$42,900.00
Sub Total (Construction)					\$501,858.77
Contingencies					20%
					\$136,371.75
Land					36,000 SF
					\$5.00
					\$180,000.00
Right of Way					- SF
					\$2.50
					\$0.00
Total (Construction)					\$818,230.53
Design and Construction Engineering					15%
					\$75,278.82
Administration, Legal, and Bond Counsel					1%
					\$5,018.59
Total (Professional Services)					\$80,297.40
<b>Grand Total</b>					<b>\$898,527.93</b>

#4

**Inadequate Retention Volume Southeast Bench B**

Item	Description	Quantity	Units	Unit Cost	Cost
1	Mobilization	1	LS	----	\$13,959.76
2	15 Inch Storm Drain	0	LF	\$65.00	\$0.00
3	18 Inch Storm Drain	1200	LF	\$65.00	\$78,000.00
4	21 Inch Storm Drain	0	LF	\$65.00	\$0.00
5	24 Inch Storm Drain	0	LF	\$70.00	\$0.00
6	30 Inch Storm Drain	0	LF	\$75.00	\$0.00
7	36 Inch Storm Drain	0	LF	\$95.00	\$0.00
8	42 Inch Storm Drain	0	LF	\$125.00	\$0.00
9	48 Inch Storm Drain	0	LF	\$155.00	\$0.00
10	Basin Grading	6000	CY	\$8.00	\$48,000.00
11	Manholes/Inlets/Structures	11	EA	\$3,500.00	\$38,500.00
12	Class "A" Road Repair	11400	SF	\$7.00	\$79,800.00
13	Class "D" Field Repair	0	SF	\$1.00	\$0.00
14	Imported Backfill	224.72	TON	\$18.00	\$4,044.94
15	Railroad Crossing	0	LS	\$108,000.00	\$0.00
16	State Road Crossing	0	LS	\$220,000.00	\$0.00
17	Traffic Control	1	LS	\$7,450.35	\$7,450.35
18	Utility Relocation (30% of pipe cost)	1	LS	\$23,400.00	\$23,400.00
Sub Total (Construction)					\$293,155.06
Contingencies					20%
					\$78,631.01
Land					20,000 SF
					\$5.00
					\$100,000.00
Right of Way					- SF
					\$2.50
					\$0.00
Total (Construction)					\$471,786.07
Design and Construction Engineering					15%
					\$43,973.26
Administration, Legal, and Bond Counsel					1%
					\$2,931.55
Total (Professional Services)					\$46,904.81
<b>Grand Total</b>					<b>\$518,690.88</b>

#5

**Inadequate Retention Volume 750 North**

Item	Description	Quantity	Units	Unit Cost	Cost
1	Mobilization	1	LS	----	\$11,231.41
2	15 Inch Storm Drain	850	LF	\$65.00	\$55,250.00
3	18 Inch Storm Drain		LF	\$65.00	\$0.00
4	21 Inch Storm Drain	0	LF	\$65.00	\$0.00
5	24 Inch Storm Drain	0	LF	\$70.00	\$0.00
6	30 Inch Storm Drain	0	LF	\$75.00	\$0.00
7	36 Inch Storm Drain	0	LF	\$95.00	\$0.00
8	42 Inch Storm Drain	0	LF	\$125.00	\$0.00
9	48 Inch Storm Drain	0	LF	\$155.00	\$0.00
10a	Basin Grading	4000	CY	\$8.00	\$32,000.00
10b	Turf Replacement	45000	SF	\$0.80	\$36,000.00
11	Manholes/Inlets/Structures	6	EA	\$3,500.00	\$21,000.00
12	Class "A" Road Repair	7862.5	SF	\$7.00	\$55,037.50
13	Class "D" Field Repair	-	SF	\$1.00	\$0.00
14	Imported Backfill	150.33	TON	\$18.00	\$2,705.99
15	Railroad Crossing	0	LS	\$108,000.00	\$0.00
16	State Road Crossing	0	LS	\$220,000.00	\$0.00
17	Traffic Control	1	LS	\$6,059.80	\$6,059.80
18	Utility Relocation (30% of pipe cost)	1	LS	\$16,575.00	\$16,575.00
Sub Total (Construction)					\$235,859.71
Contingencies					20%
					\$47,171.94
Land					SF
					\$5.00
					\$0.00
Right of Way					-
					SF
					\$2.50
Total (Construction)					\$283,031.65
Design and Construction Engineering					15%
					\$35,378.96
Administration, Legal, and Bond Counsel					1%
					\$2,358.60
Total (Professional Services)					\$37,737.55
<b>Grand Total</b>					<b>\$320,769.21</b>



#6

**Inadequate Retention Volume North 350 West**

Item	Description	Quantity	Units	Unit Cost	Cost
1	Mobilization	1	LS	----	\$3,066.36
2	15 Inch Storm Drain	80	LF	\$65.00	\$5,200.00
3	18 Inch Storm Drain	0	LF	\$65.00	\$0.00
4	21 Inch Storm Drain	0	LF	\$65.00	\$0.00
5	24 Inch Storm Drain	0	LF	\$70.00	\$0.00
6	30 Inch Storm Drain	0	LF	\$75.00	\$0.00
7	36 Inch Storm Drain	0	LF	\$95.00	\$0.00
8	42 Inch Storm Drain	0	LF	\$125.00	\$0.00
9	48 Inch Storm Drain	0	LF	\$155.00	\$0.00
10a	Basin Grading	1613	CY	\$8.00	\$12,906.67
10b	Turf Replacement	0	sq ft	\$0.80	\$0.00
11	Manholes/Inlets/Structures	4	EA	\$3,500.00	\$14,000.00
12	Class "A" Road Repair	555	SF	\$7.00	\$3,885.00
13	Class "D" Field Repair	21,780	SF	\$1.00	\$21,780.00
14	Imported Backfill	14.15	TON	\$18.00	\$254.68
15	Railroad Crossing	0	LS	\$108,000.00	\$0.00
16	State Road Crossing	0	LS	\$220,000.00	\$0.00
17	Traffic Control	1	LS	\$1,740.79	\$1,740.79
18	Utility Relocation (30% of pipe cost)	1	LS	\$1,560.00	\$1,560.00
Sub Total (Construction)					\$64,393.50
Contingencies		20%			\$34,658.70
Land		21,780	SF	\$5.00	\$108,900.00
Right of Way		-	SF	\$2.50	\$0.00
Total (Construction)					\$207,952.19
Design and Construction Engineering		15%			\$9,659.02
Administration, Legal, and Bond Counsel		1%			\$643.93
Total (Professional Services)					\$10,302.96
<b>Grand Total</b>					<b>\$218,255.15</b>

#7

## 400 E 400 S Flooding

Item	Description	Quantity	Units	Unit Cost	Cost
1	Mobilization	1	LS	----	\$5,708.98
2	15 Inch Storm Drain	250	LF	\$65.00	\$16,250.00
3	18 Inch Storm Drain	0	LF	\$65.00	\$0.00
4	21 Inch Storm Drain	0	LF	\$65.00	\$0.00
5	24 Inch Storm Drain	0	LF	\$70.00	\$0.00
6	30 Inch Storm Drain	0	LF	\$75.00	\$0.00
7	36 Inch Storm Drain	0	LF	\$95.00	\$0.00
8	42 Inch Storm Drain	0	LF	\$125.00	\$0.00
9	48 Inch Storm Drain	0	LF	\$155.00	\$0.00
10	Curb and Gutter	2500	LF	\$17.00	\$42,500.00
11	Basin Grading	645	CY	\$8.00	\$5,162.67
12	Manholes/Inlets/Structures	8	EA	\$3,500.00	\$28,000.00
13	Class "A" Road Repair	1850	SF	\$7.00	\$12,950.00
14	Class "D" Field Repair	462.5	SF	\$1.00	\$462.50
15	Imported Backfill	44.22	TON	\$18.00	\$795.88
16	Railroad Crossing	0	LS	\$108,000.00	\$0.00
17	State Road Crossing	0	LS	\$220,000.00	\$0.00
18	Traffic Control	1	LS	\$3,183.63	\$3,183.63
19	Utility Relocation (30% of pipe cost)	1	LS	\$4,875.00	\$4,875.00
Sub Total (Construction)					\$119,888.66
Contingencies					20%
					\$23,977.73
Land					SF
					\$5.00
Right of Way					-
					SF
					\$2.50
Total (Construction)					\$143,866.39
Design and Construction Engineering					15%
					\$17,983.30
Administration, Legal, and Bond Counsel					1%
					\$1,198.89
Total (Professional Services)					\$19,182.19
<b>Grand Total</b>					<b>\$163,048.58</b>

#8

## Lack of Retention at 680 N and 560 W

Item	Description	Quantity	Units	Unit Cost	Cost
1	Mobilization	1	LS	----	\$990.77
2	15 Inch Storm Drain	50	LF	\$65.00	\$3,250.00
3	18 Inch Storm Drain	0	LF	\$65.00	\$0.00
4	21 Inch Storm Drain	0	LF	\$65.00	\$0.00
5	24 Inch Storm Drain	0	LF	\$70.00	\$0.00
6	30 Inch Storm Drain	0	LF	\$75.00	\$0.00
7	36 Inch Storm Drain	0	LF	\$95.00	\$0.00
8	42 Inch Storm Drain	0	LF	\$125.00	\$0.00
9	48 Inch Storm Drain	0	LF	\$155.00	\$0.00
10	Basin Grading	650	CY	\$8.00	\$5,200.00
11	Manholes/Inlets/Structures	2	EA	\$3,500.00	\$7,000.00
12	Class "A" Road Repair	370	SF	\$7.00	\$2,590.00
13	Class "D" Field Repair	92.5	SF	\$1.00	\$92.50
14	Imported Backfill	8.84	TON	\$18.00	\$159.18
15	Railroad Crossing	0	LS	\$108,000.00	\$0.00
16	State Road Crossing	0	LS	\$220,000.00	\$0.00
17	Traffic Control	1	LS	\$548.75	\$548.75
18	Utility Relocation (30% of pipe cost)	1	LS	\$975.00	\$975.00
Sub Total (Construction)					\$20,806.20
Contingencies					20%
					\$19,161.24
Land					15,000 SF
					\$5.00
					\$75,000.00
Right of Way					- SF
					\$2.50
					\$0.00
Total (Construction)					\$114,967.44
Design and Construction Engineering					15%
					\$3,120.93
Administration, Legal, and Bond Counsel					1%
					\$208.06
Total (Professional Services)					\$3,328.99
<b>Grand Total</b>					<b>\$118,296.43</b>

#9

## Town Center Improvements

	Curb and Gutter Approach				
	Saw cut and tie in w/ one inch overlay over existing pavement				
Item	Unit	Quantity	Unit Cost	Cost	
HMA	ton	413	\$ 75.00	\$ 30,937.50	
UTBC	cu yd	326	\$ 23.00	\$ 7,496.30	
Sub-base (12" thick)	cu yd	500	\$ 21.00	\$ 10,500.00	
Curb and Gutter	ft	2,200	\$ 22.00	\$ 48,400.00	
Catch Basin	ea	8	\$ 3,500.00	\$ 28,000.00	
15" Storm Drain Pipe	ft	50	\$ 55.00	\$ 2,750.00	
Pretreatment Structure	ea	0	\$ 10,000.00	\$ -	
Saw Cut	ft	2,200	\$ 2.50	\$ 5,500.00	
Storm chamber	ft	610	\$ 100.00	\$ 61,000.00	
Concrete drive approach	sq ft	900	\$ 11.00	\$ 9,900.00	
16' wide park strip	sq ft	35,200	\$ 1.00	\$ 35,200.00	
Parkstrip sprinkler system	ea	15	\$ 1,500.00	\$ 22,500.00	
5' wide sidewalk	sq ft	11,000	\$ 10.00	\$ 110,000.00	
Traffic Control	lump	1	\$ 18,609	\$ 18,609.19	
Subtotal (Construction)				\$ 390,792.99	
Contingency (15%)				\$ 58,618.95	
Design and Construction Engineering (15%)				\$ 58,618.95	
Administrative, Legal, Bond Counsel (2%)				\$ 7,815.86	
Total Professional Services				\$ 66,434.81	
	<b>Total</b>			<b>\$ 515,847</b>	

	No Curb and Gutter Approach				
	Item	Unit	Quantity	Unit Cost	Cost
Roadside swale or ditch grading	lump	1	\$ 30,000	\$ 30,000	
Driveway culverts	ft	200	\$ 55.00	\$ 11,000	
Catch Basin	ea	6	\$ 3,500	\$ 21,000	
Pretreatment Structure	ft	0	\$ 10,000	\$ -	
15" Storm Drain Pipe	ft	320	\$ 55.00	\$ 17,600.00	
Storm chamber	ea	610	\$ 100.00	\$ 61,000.00	
Traffic Control	lump	1	\$ 7,030.00	\$ 7,030.00	
Subtotal (Construction)				\$ 147,630.00	
Contingency (15%)				\$ 22,144.50	
Design and Construction Engineering (15%)				\$ 22,144.50	
Administrative, Legal, Bond Counsel (2%)				\$ 2,952.60	
Total Professional Services				\$ 25,097.10	
	<b>Total</b>			<b>\$ 194,872</b>	

#10

## Drainage Problem at Lambert Ave/SR-198

Item	Description	Quantity	Units	Unit Cost	Cost
1	Mobilization	1	LS	----	\$1,340.97
2	15 Inch Storm Drain	50	LF	\$65.00	\$3,250.00
3	18 Inch Storm Drain	0	LF	\$65.00	\$0.00
4	21 Inch Storm Drain	0	LF	\$65.00	\$0.00
5	24 Inch Storm Drain	0	LF	\$70.00	\$0.00
6	30 Inch Storm Drain	0	LF	\$75.00	\$0.00
7	36 Inch Storm Drain	0	LF	\$95.00	\$0.00
8	42 Inch Storm Drain	0	LF	\$125.00	\$0.00
9	48 Inch Storm Drain	0	LF	\$155.00	\$0.00
10	Curb and Gutter	500	LF	\$17.00	\$8,500.00
11	Basin Grading	0	CY	\$8.00	\$0.00
12	Manholes/Inlets/Structures	3	EA	\$3,500.00	\$10,500.00
13	Class "A" Road Repair	370	SF	\$7.00	\$2,590.00
14	Class "D" Field Repair	92.5	SF	\$1.00	\$92.50
15	Imported Backfill	8.84	TON	\$18.00	\$159.18
16	Railroad Crossing	0	LS	\$108,000.00	\$0.00
17	State Road Crossing	0	LS	\$220,000.00	\$0.00
18	Traffic Control	1	LS	\$752.75	\$752.75
19	Utility Relocation (30% of pipe cost)	1	LS	\$975.00	\$975.00
Sub Total (Construction)					\$28,160.40
Contingencies		20%			\$5,632.08
Land			SF	\$5.00	\$0.00
Right of Way		-	SF	\$2.50	\$0.00
Total (Construction)					\$33,792.48
Design and Construction Engineering		15%			\$4,224.06
Administration, Legal, and Bond Counsel		1%			\$281.60
Total (Professional Services)					\$4,505.66
<b>Grand Total</b>					<b>\$38,298.14</b>

#11

## NRCS Channel in disrepair

Item	Description	Quantity	Units	Unit Cost	Cost
1	Mobilization	1	LS	----	\$19,131.64
2	15 Inch Storm Drain	0	LF	\$65.00	\$0.00
3	18 Inch Storm Drain	800	LF	\$65.00	\$52,000.00
4	21 Inch Storm Drain	0	LF	\$65.00	\$0.00
5	24 Inch Storm Drain	1000	LF	\$70.00	\$70,000.00
6	30 Inch Storm Drain	500	LF	\$75.00	\$37,500.00
7	36 Inch Storm Drain	0	LF	\$95.00	\$0.00
8	42 Inch Storm Drain	0	LF	\$125.00	\$0.00
9	48 Inch Storm Drain	0	LF	\$155.00	\$0.00
10	Basin Grading	0	CY	\$8.00	\$0.00
11	Manholes/Inlets/Structures	7	EA	\$3,500.00	\$24,500.00
12	Class "A" Road Repair	18280	SF	\$7.00	\$127,960.00
13	Class "D" Field Repair	4570	SF	\$1.00	\$4,570.00
14	Imported Backfill	472.33	TON	\$18.00	\$8,501.87
15	Railroad Crossing	0	LS	\$108,000.00	\$0.00
16	State Road Crossing	0	LS	\$220,000.00	\$0.00
17	Traffic Control	1	LS	\$9,750.96	\$9,750.96
18	Utility Relocation (30% of pipe cost)	1	LS	\$47,850.00	\$47,850.00
Sub Total (Construction)					\$401,764.47
Contingencies					20%
					\$80,352.89
Land					SF
					\$5.00
Right of Way					- SF
					\$2.50
Total (Construction)					\$482,117.36
Design and Construction Engineering					15%
					\$60,264.67
Administration, Legal, and Bond Counsel					1%
					\$4,017.64
Total (Professional Services)					\$64,282.32
<b>Grand Total</b>					<b>\$546,399.68</b>

This cost is not included in the existing deficiencies as the cost should be covered by the County and/or NRCS.

## APPENDIX C – TOWN CENTER OPTIONS

- Town Center Block by Block Infiltration Storm Chamber Gallery Figure
- Town Center Block by Block Pipe and Infiltration Gallery Figure
- Town Center Common Infiltration Pipeline Figure
- Estimates

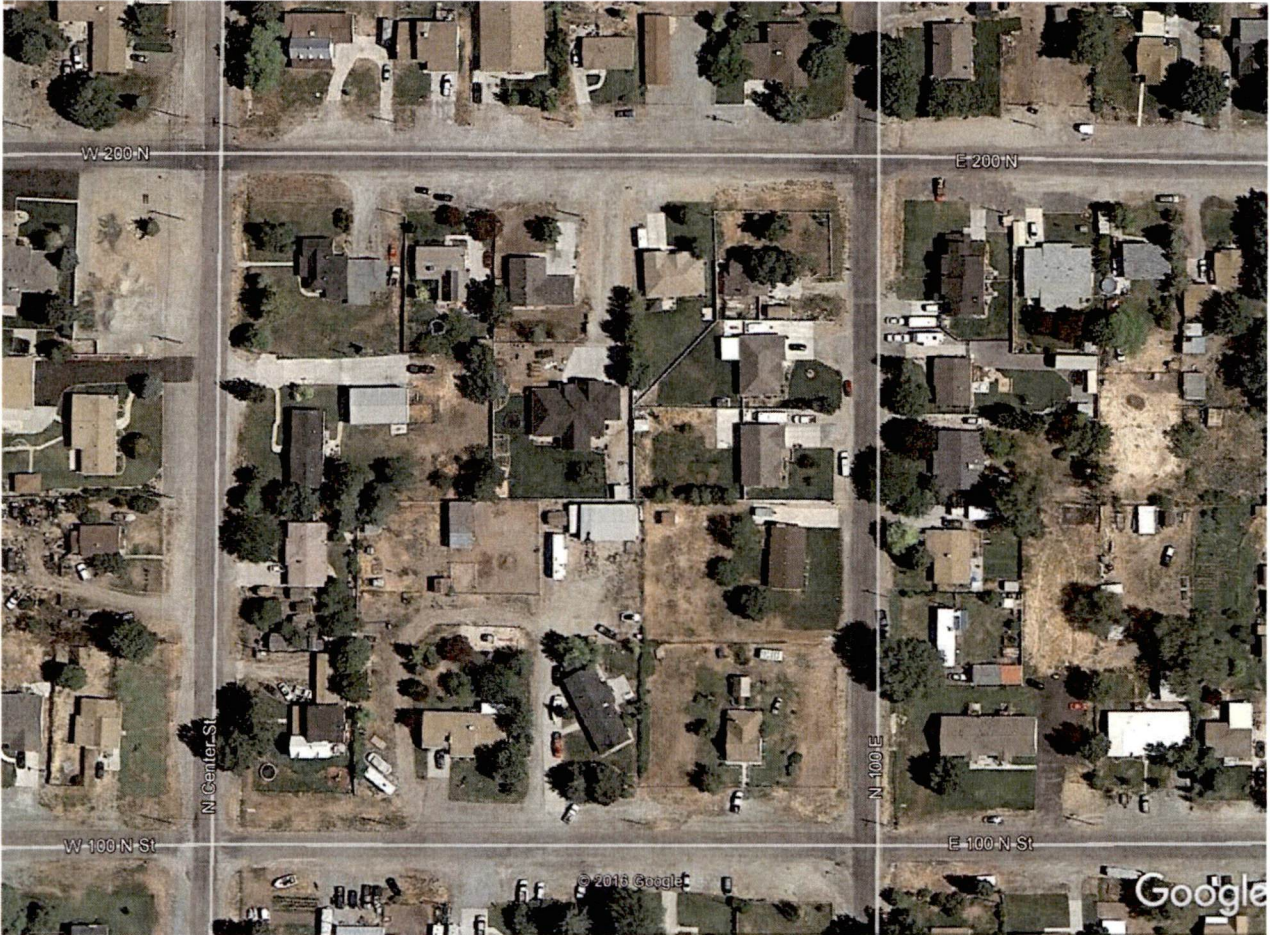



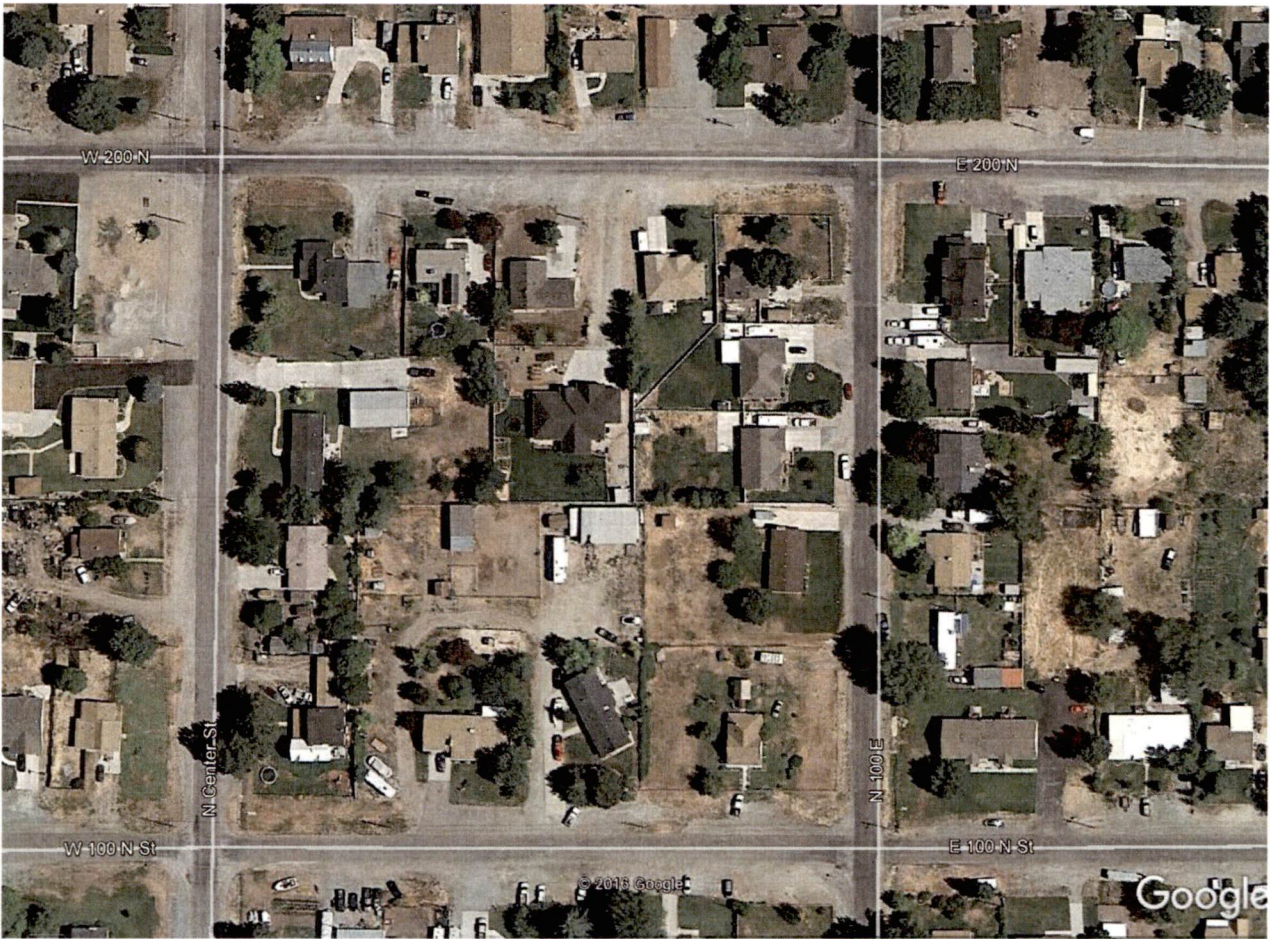

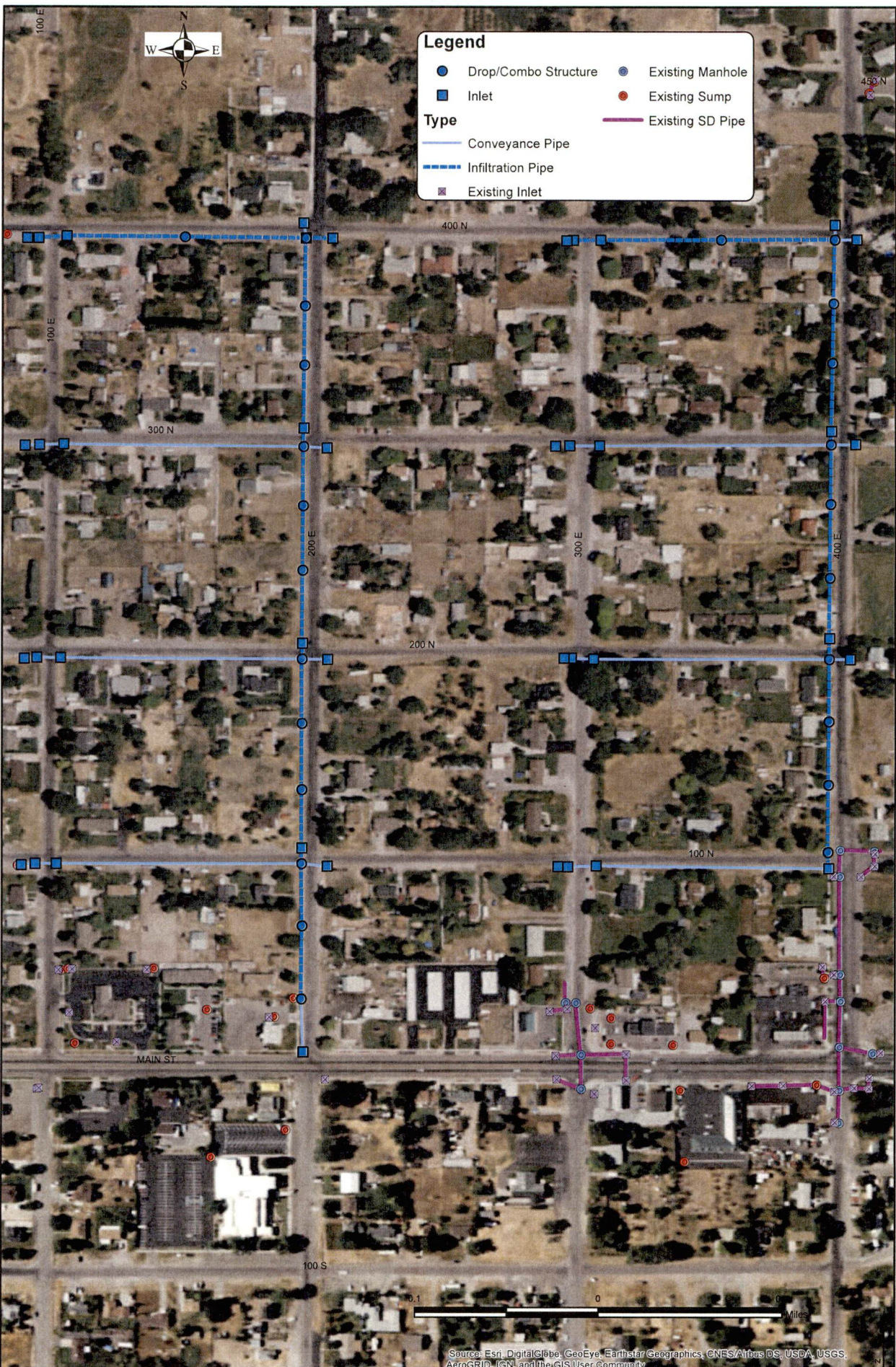

**Legend**

- Drop/Combo Structure
- Inlet
- Conveyance Pipe
- - - Infiltration Pipe
- ⊗ Existing Inlet
- Existing Manhole
- Existing Sump
- Existing SD Pipe

012018P02-131-612\_Sarasota\_City\_Sewer\_Water\_Plant\_Project\_Draft\_2(S)Horrocks\_MxP\_Report\_Town\_Center\_Options\_Town\_Center\_Turndell\_Options.mxd 7/27/2017 2:22:19 PM aaronm

Source: Esri, DigitalGlobe, GeoEye, Earthstar Geographics, CNES/Airbus DS, USDA, USGS, AeroGRID, IGN, and the GIS User Community

<b>Option 2: Central Infiltration Line</b> City Center Drainage		DATE 7/27/2017
		DRAWN Figure 1

## APPENDIX D – BUILDOUT CONDITIONS WATERSHED MAP

- Buildout Conditions Watershed Map

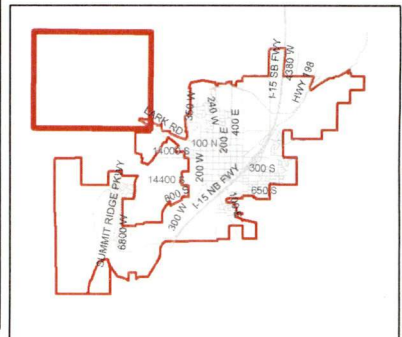

Proposed Watersheds  
Santaquin City

11/22/2017  
Figure 1

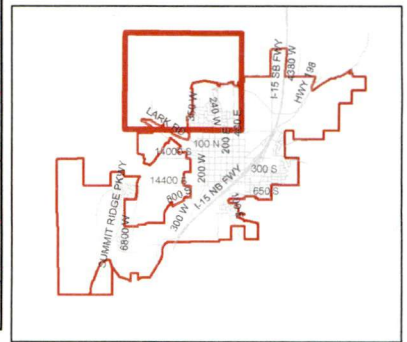
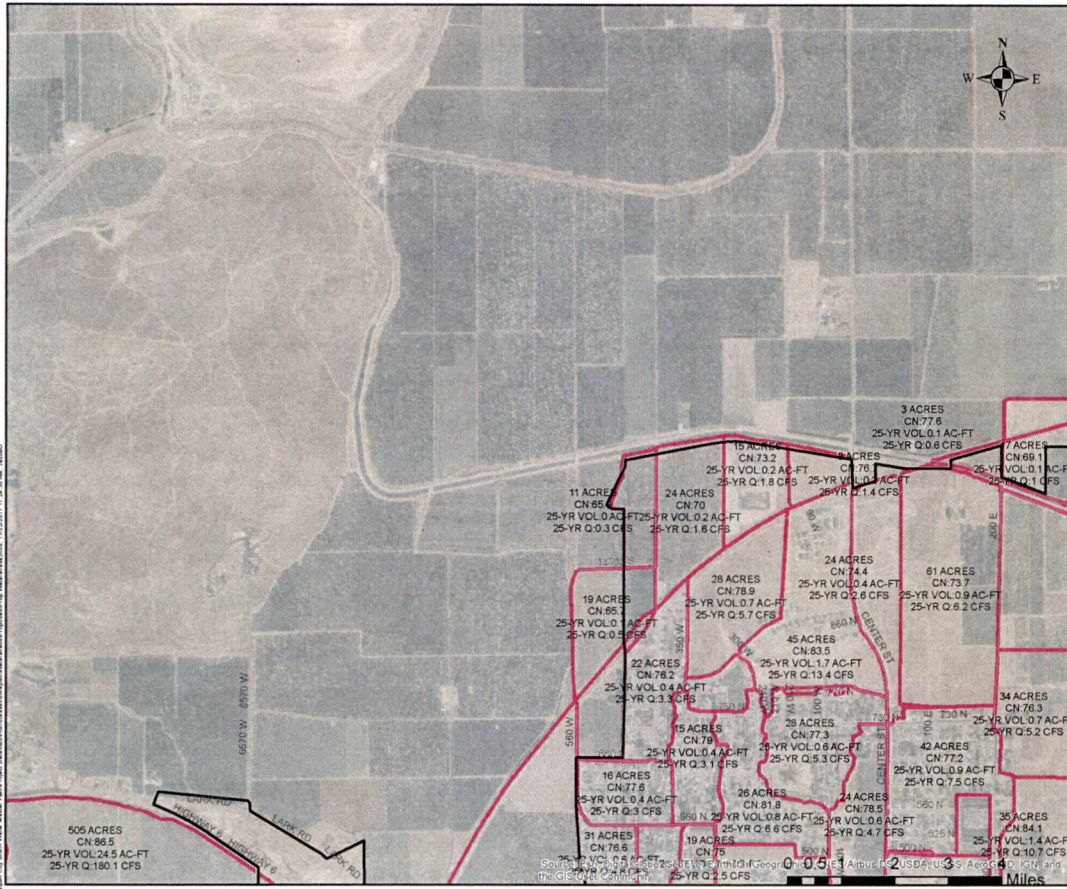

Proposed Watersheds

Santaquin City

11/22/2017

Figure 1

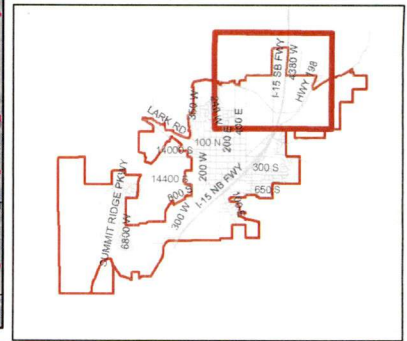
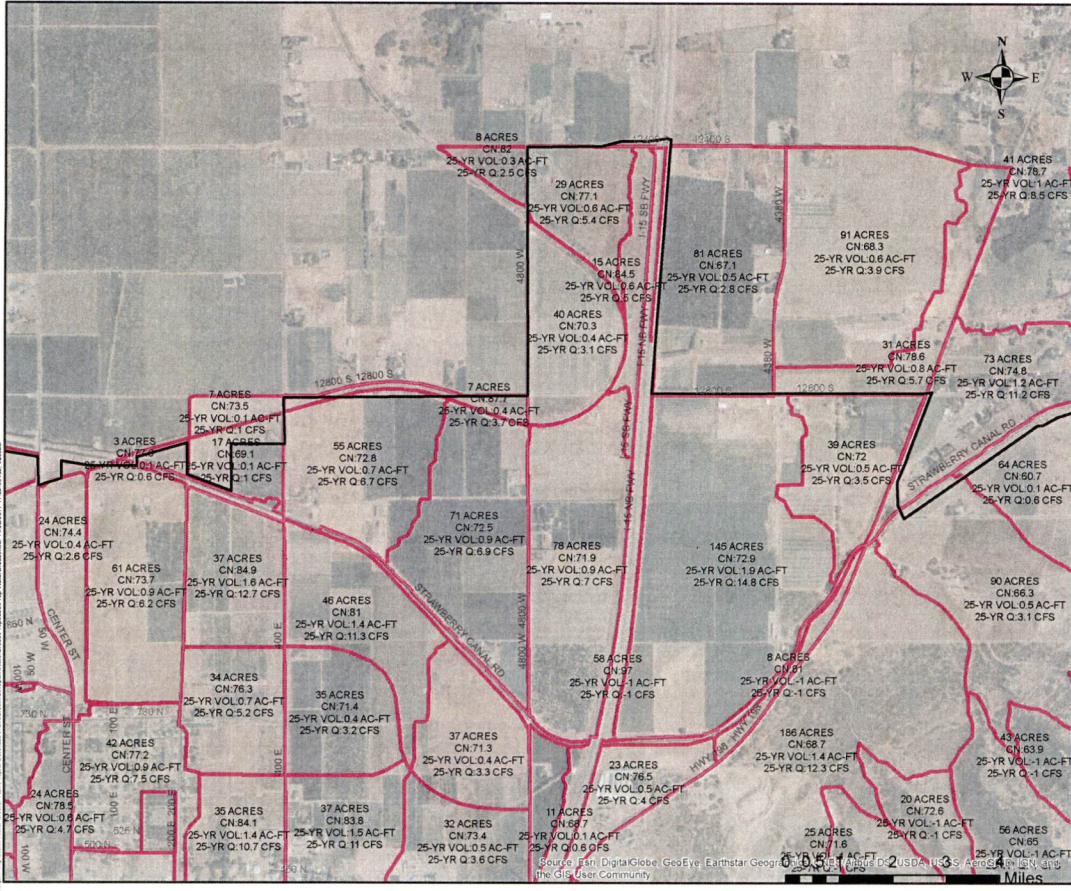

Proposed Watersheds

Santaquin City

11/22/2017

Figure 1

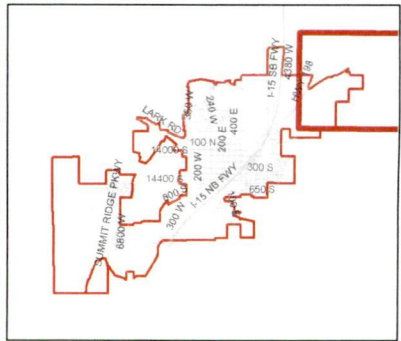
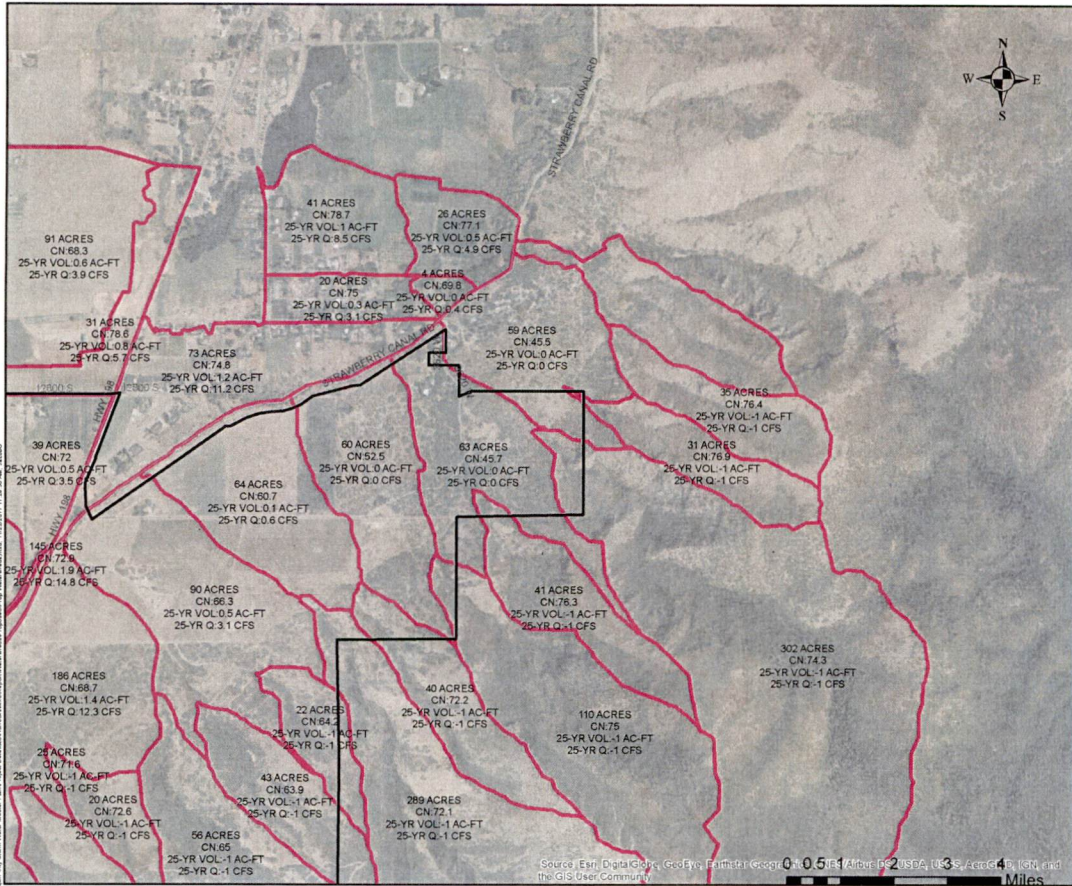

Proposed Watersheds

Santaquin City

11/22/2017

Figure 1

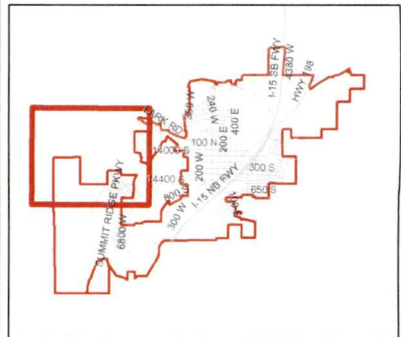
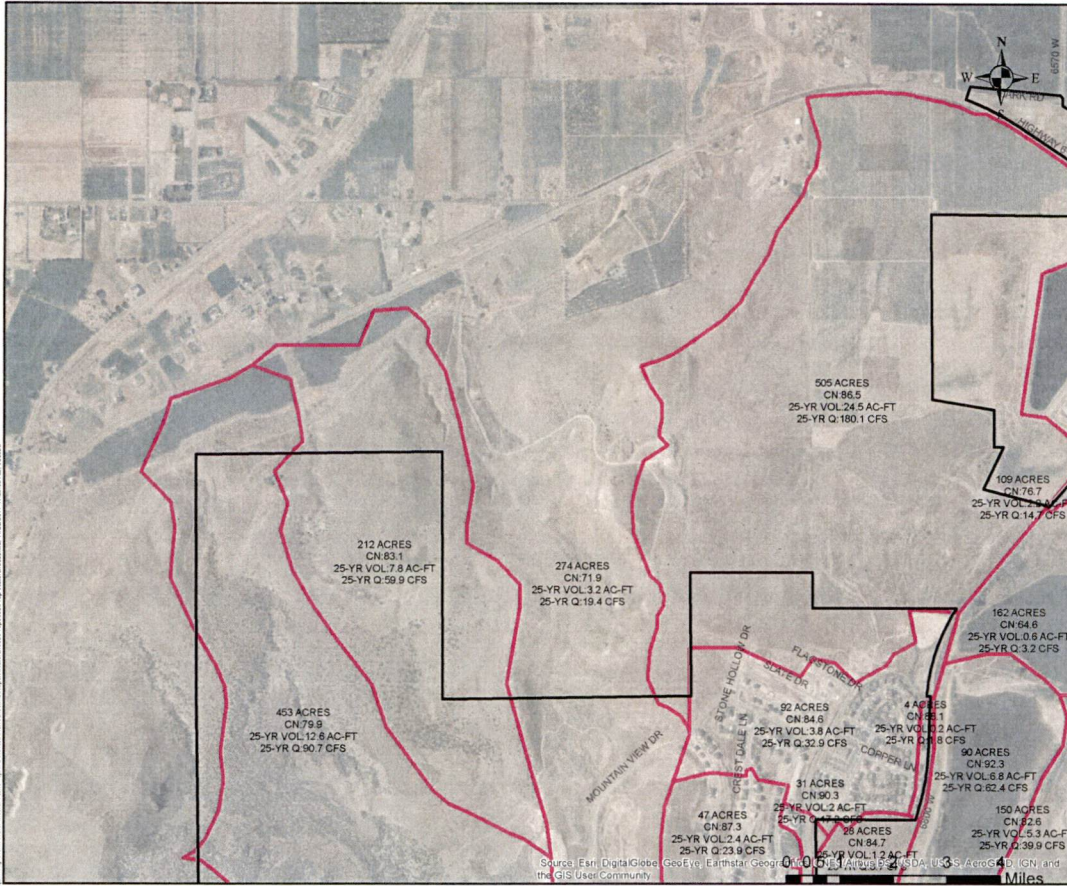

Proposed Watersheds

Santaquin City

11/22/2017

Figure 1

© 2017 Esri. All rights reserved. Esri, the Esri logo, ArcGIS, and the ArcGIS logo are either registered trademarks or trademarks of Esri in the United States and/or other countries. Microsoft, Bing, and the Bing logo are either registered trademarks or trademarks of Microsoft in the United States and/or other countries.



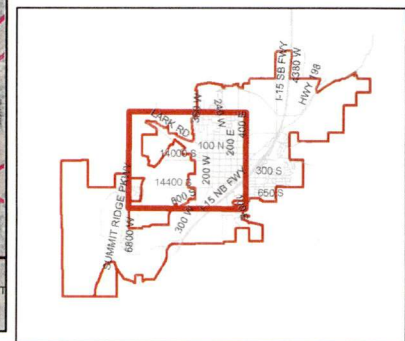
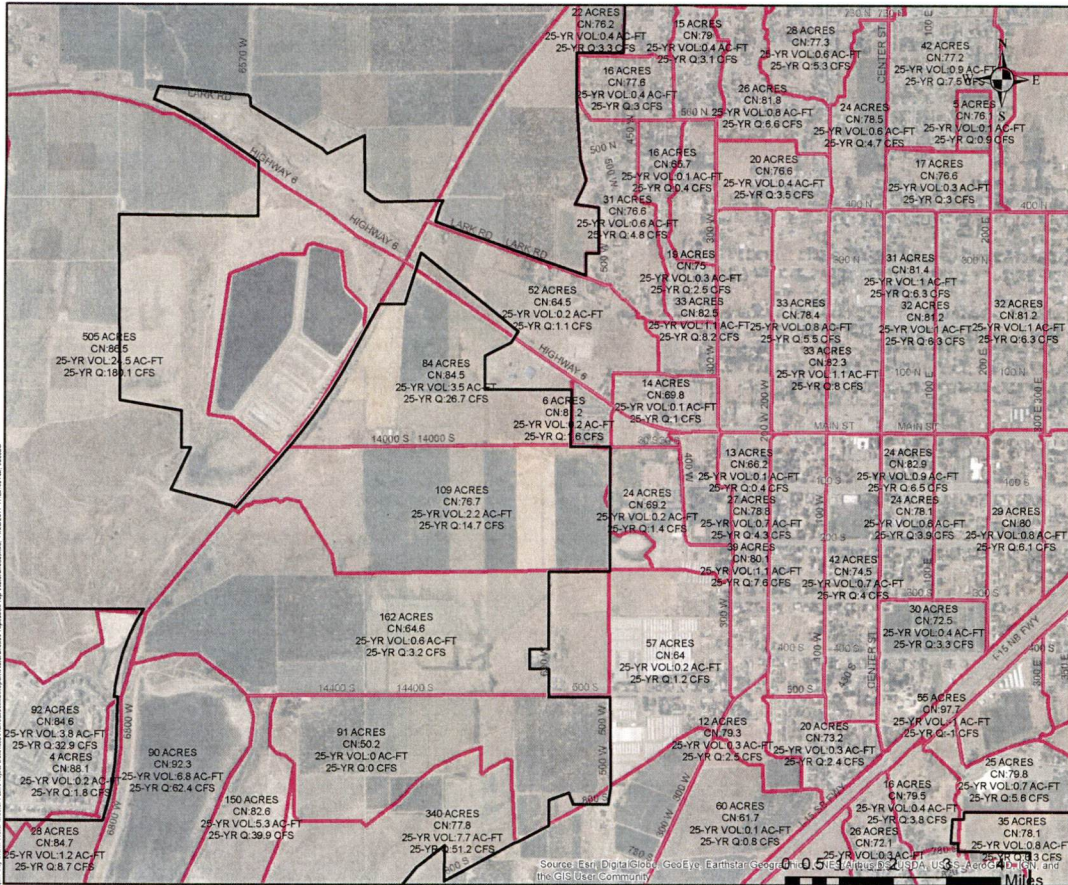

Proposed Watersheds  
Santaquin City

11/22/2017  
Figure 1

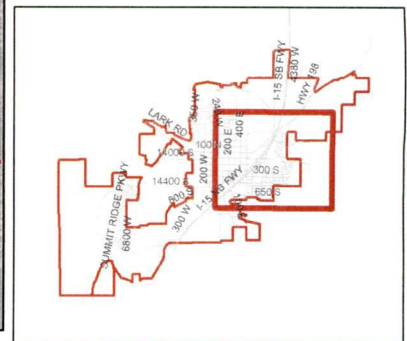
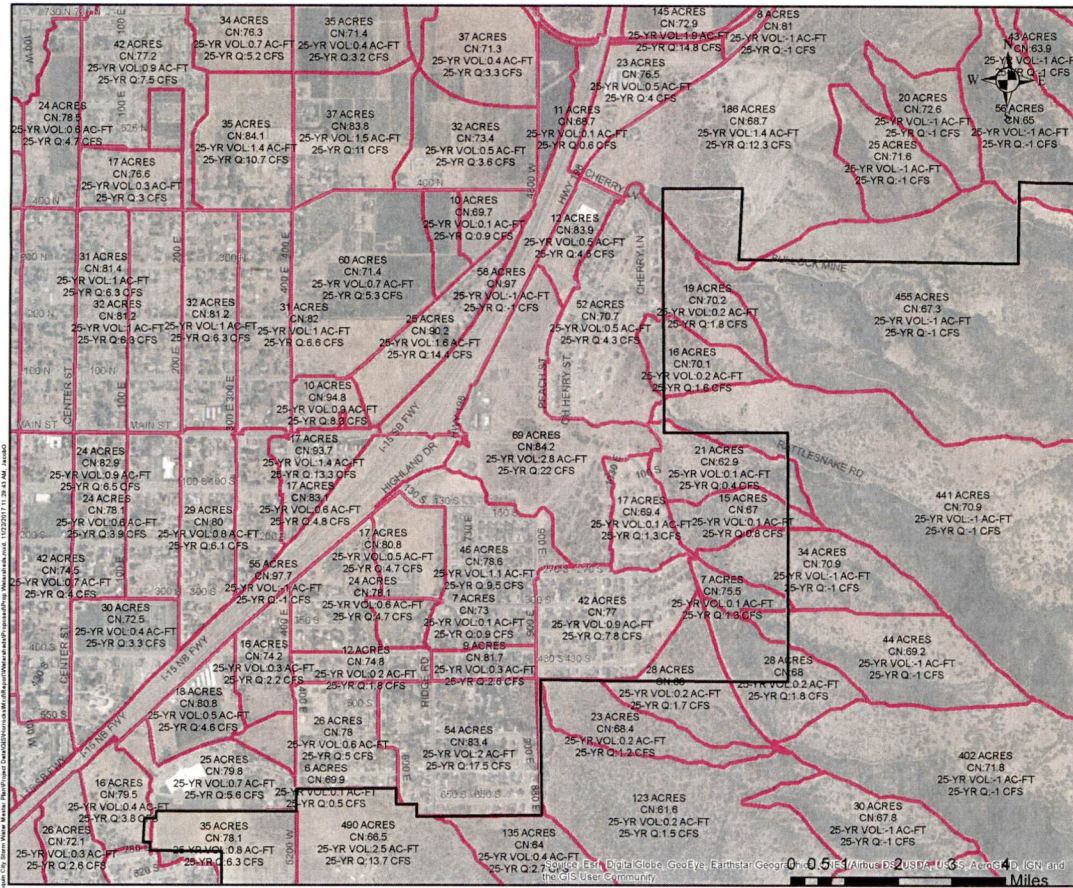

Proposed Watersheds

Santaquin City

11/22/2017

Figure 1

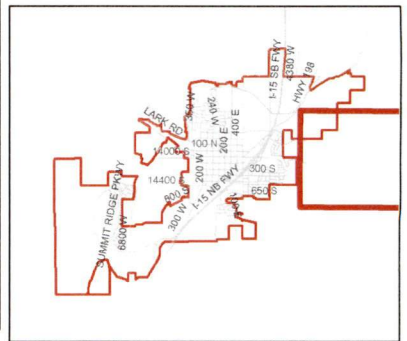
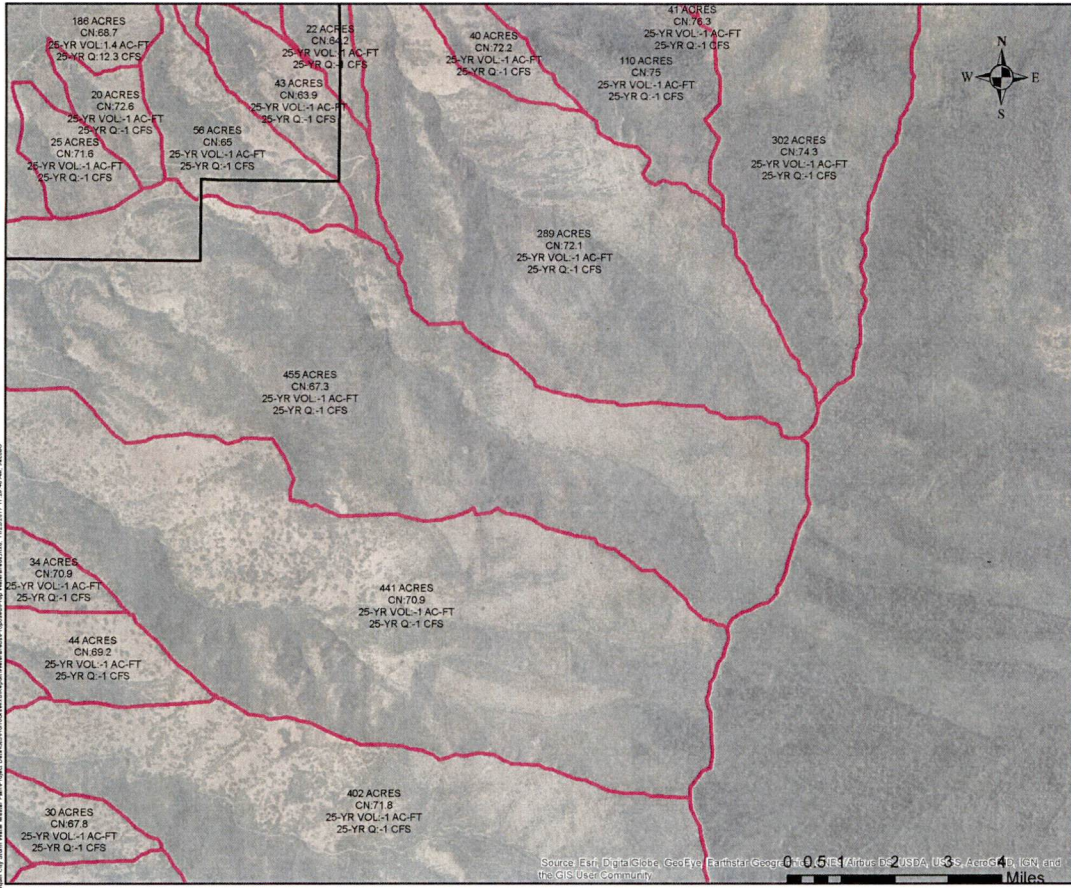

Proposed Watersheds

Santaquin City

11/22/2017

Figure 1

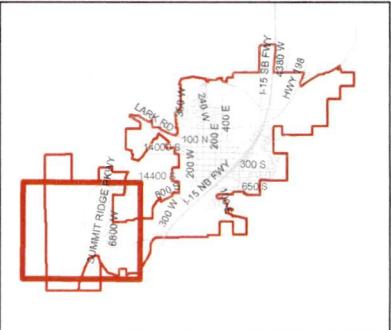
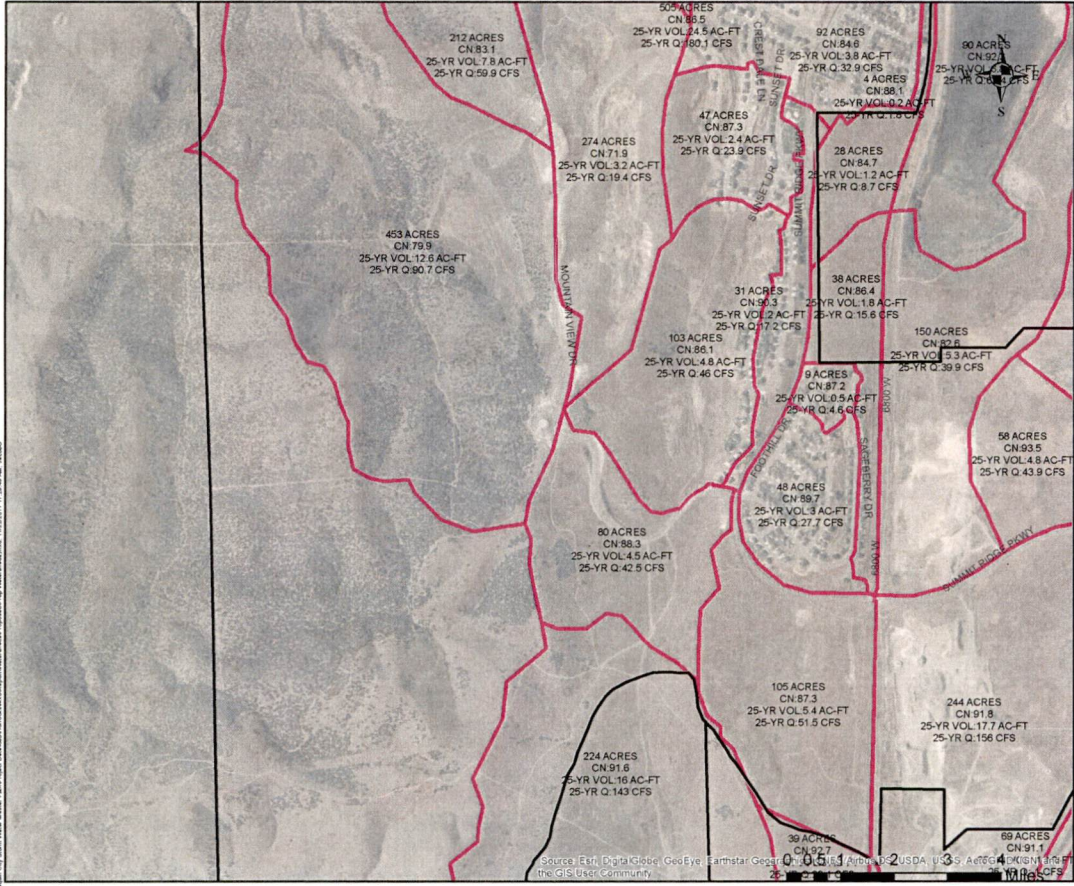

© 2008 ESRI. All rights reserved. This software is provided under a license agreement with the user. For more information, contact your local ESRI representative.



Proposed Watersheds

Santaquin City

11/22/2017

Figure 1

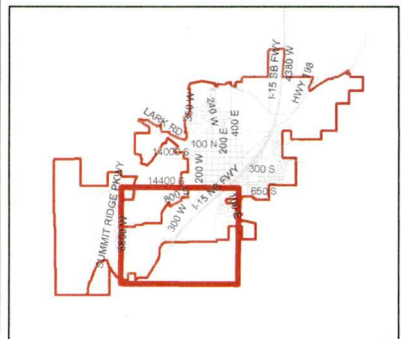
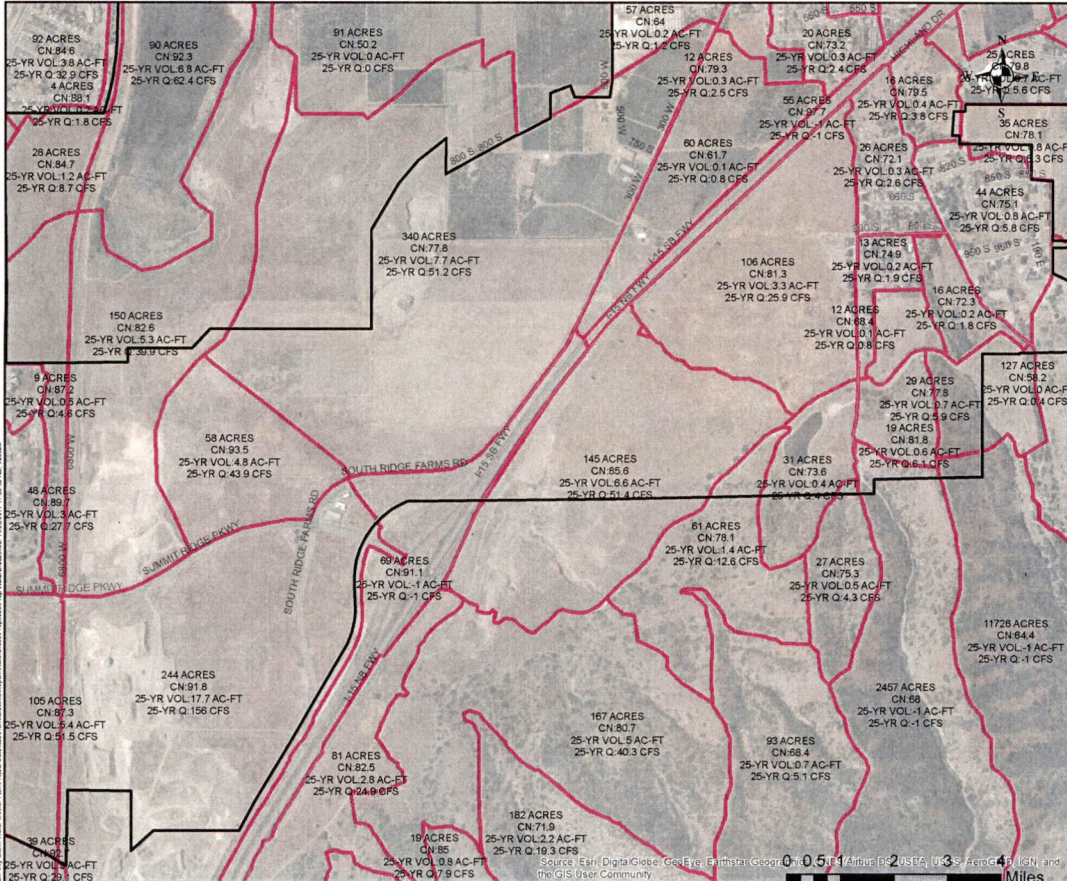

Proposed Watersheds  
Santaquin City

11/22/2017  
Figure 1

© 2017 Esri, All Rights Reserved. Esri, the Esri logo, ArcGIS, the ArcGIS logo, and the ArcGIS User Community are either registered trademarks or trademarks of Esri in the United States and/or other countries. Microsoft, the Microsoft Dynamics logo, and the Microsoft Dynamics logo are either registered trademarks or trademarks of Microsoft in the United States and/or other countries. Other brands and product names are trademarks of their respective owners.

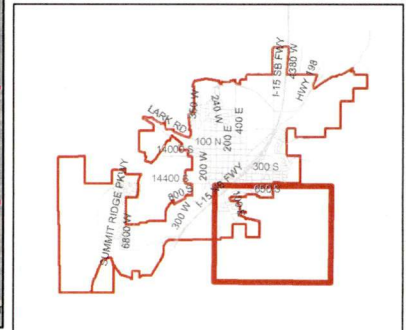
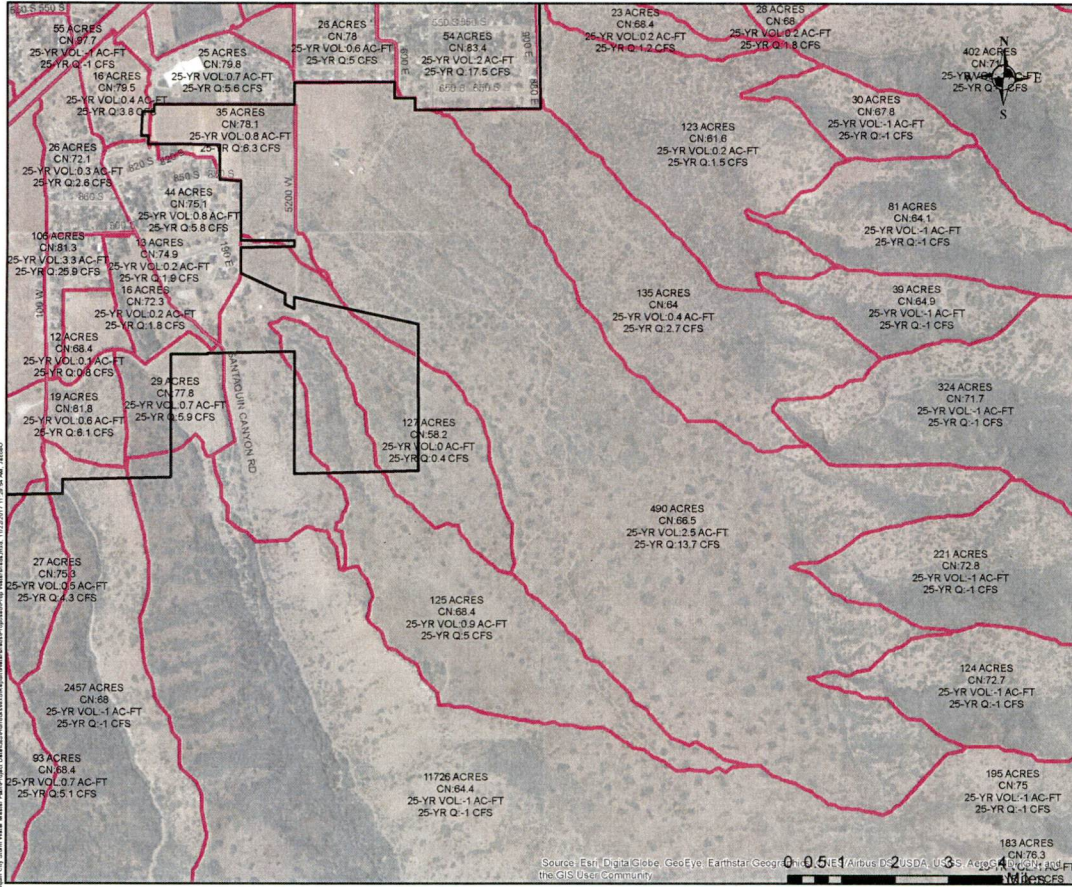

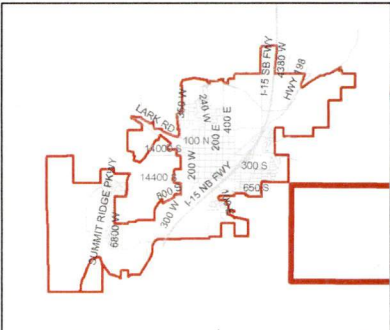
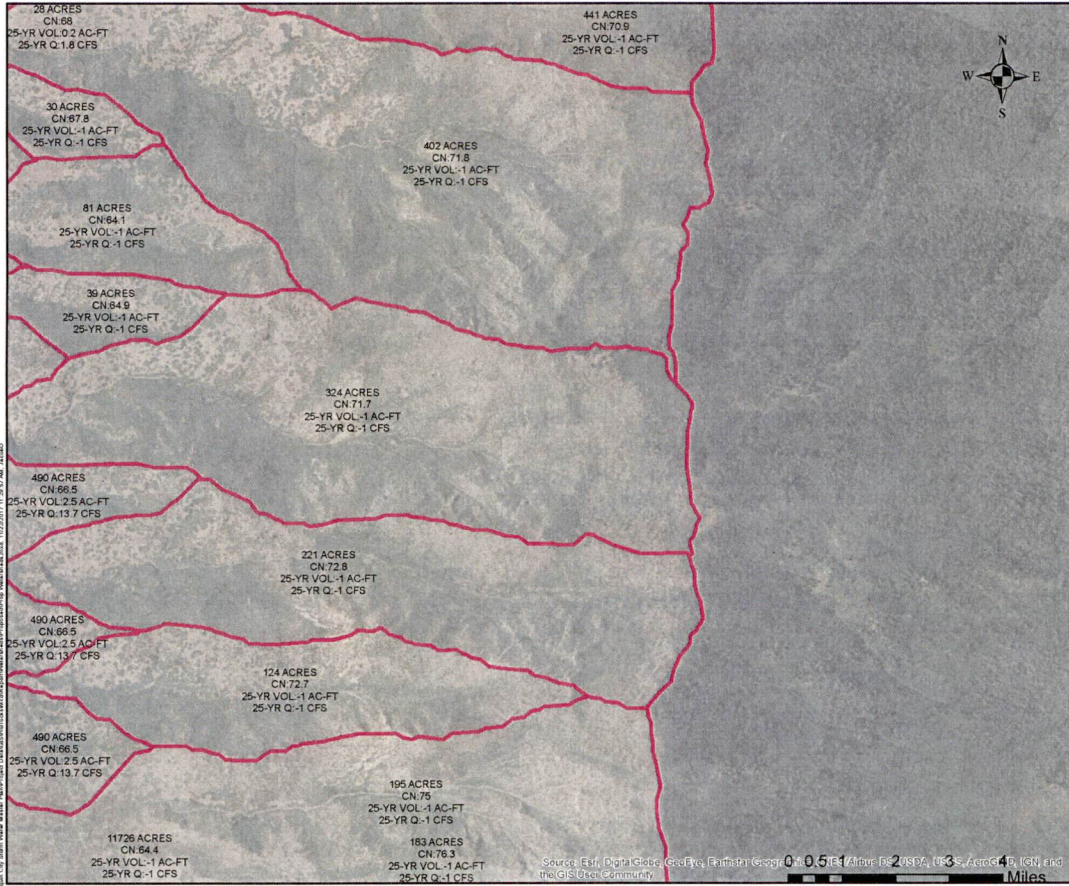

Proposed Watersheds  
Santaquin City

11/22/2017  
Figure 1

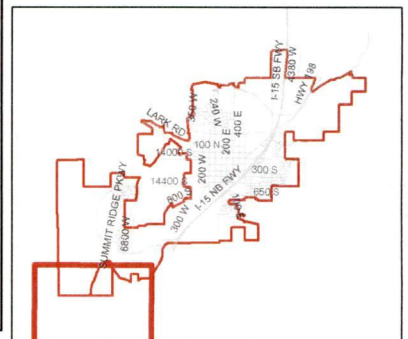
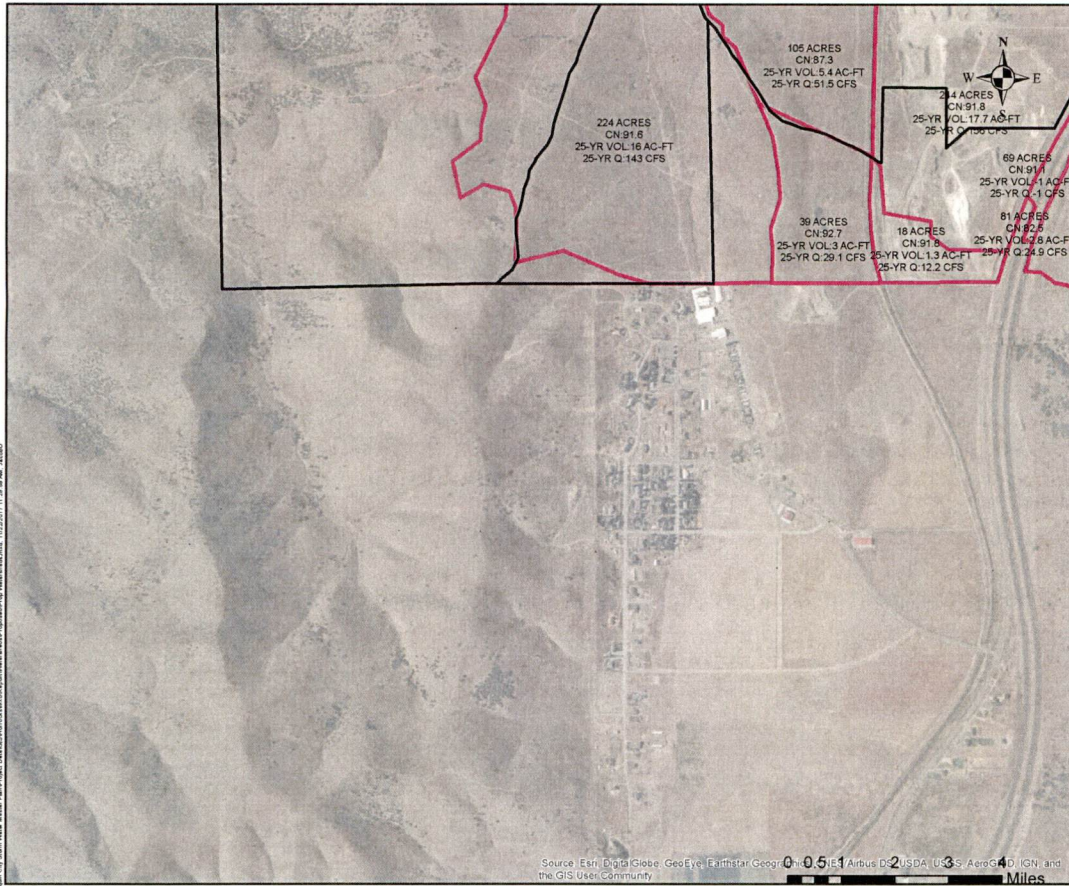

© 2017 Esri, All Rights Reserved. City of Santaquin, Utah. All rights reserved. 11/22/2017 11:28 AM. 11/22/2017



Proposed Watersheds

Santaquin City

11/22/2017

Figure 1



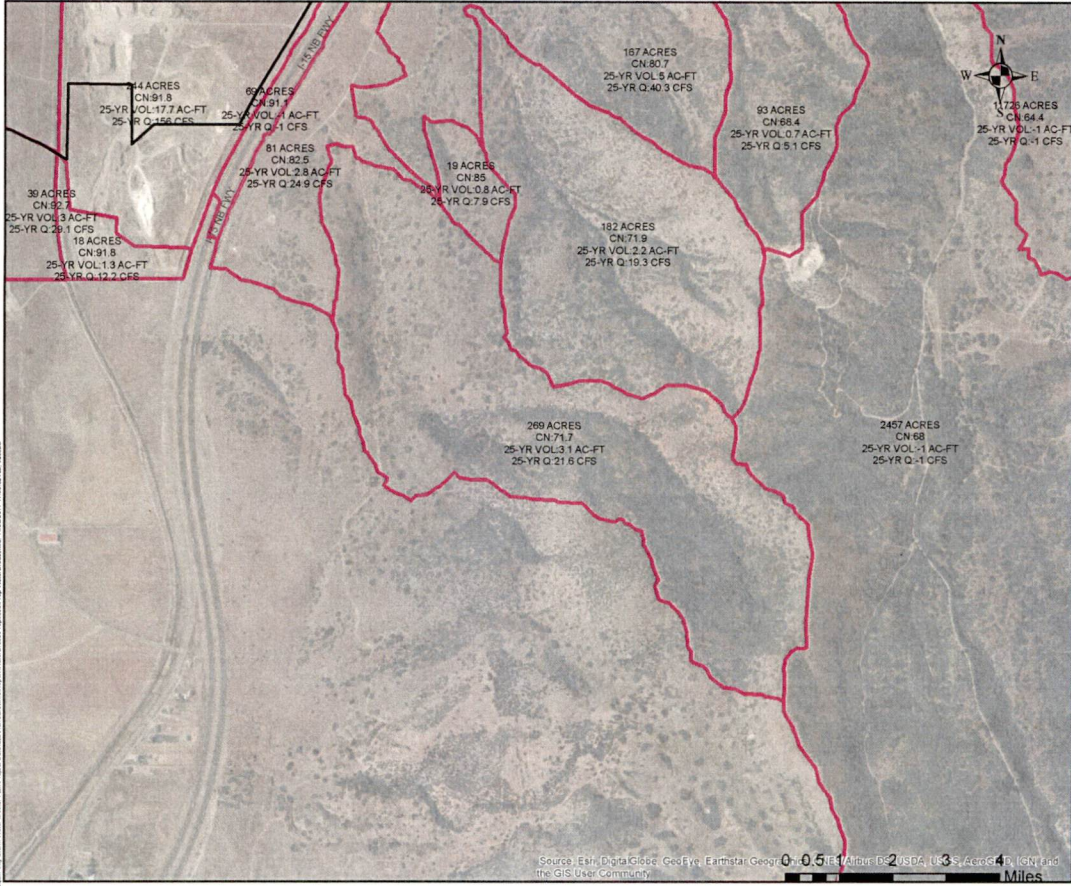

Source: Esri, DigitalGlobe, GeoEye, Earthstar, GeoEye, USDA, USGS, AeroGRID, IGN, and the GIS User Community

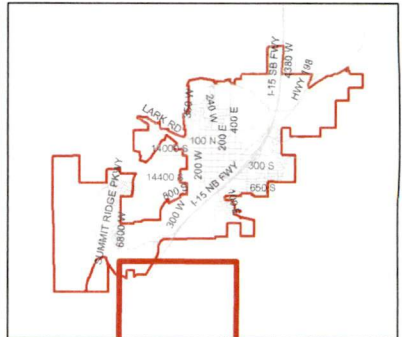

Proposed Watersheds

Santaquin City

11/22/2017

Figure 1

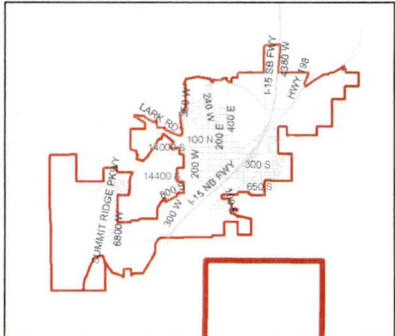

Proposed Watersheds  
Santaquin City

11/22/2017  
Figure 1

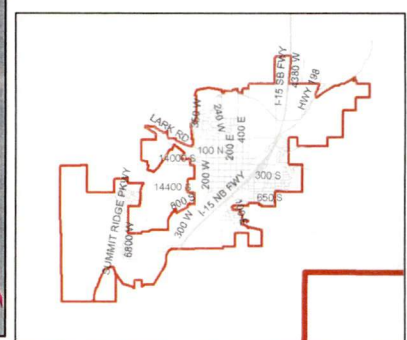
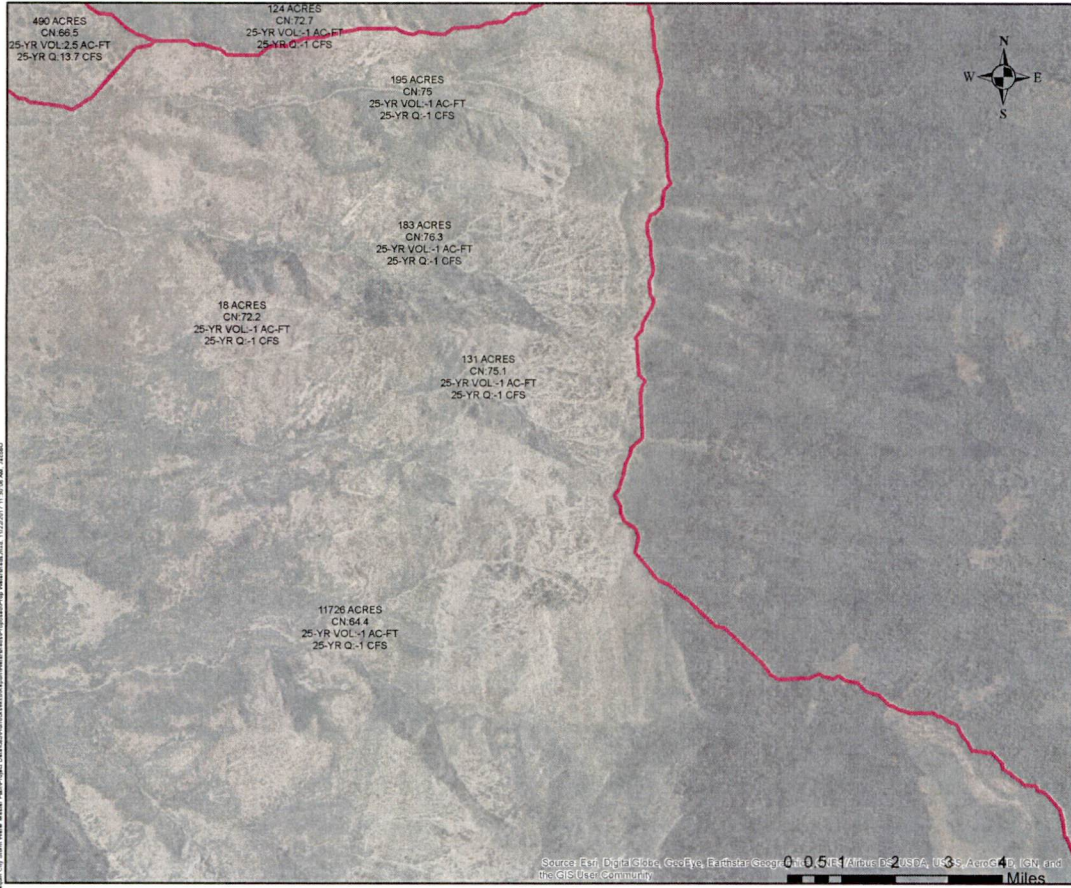

Proposed Watersheds  
Santaquin City

11/22/2017  
Figure 1

## APPENDIX E – BUILDOUT CONDITIONS PROJECT ESTIMATES

- Buildout Conditions Future Project Estimates

Project No. Project Description Volume GIS ID No.  
 #1 Northwest Industrial Regional Pond #1 3.1 AC-FT 8

Item	Description	Quantity	Units	Unit Cost	Cost
1	Basin Grading	4945	CY	\$10.00	\$49,450.00
2	Landscaping - Grass	44518	SF	\$1.00	\$44,518.00
3	Seeding	1.0	Acre	\$1,000.00	\$1,000.00
4	Land Acquisition	44518	SF	\$4.00	\$178,072.00
5	Easement Acquisition	0	SF	\$2.50	\$0.00
6	Inlet	1	LS	\$21,000.00	\$21,000.00
7	Spillway	1	LS	\$21,000.00	\$21,000.00
Sub Total (Construction)					\$315,040.00
Contingencies		10%			\$31,504.00
Total (Construction)					\$346,544.00
Design and Construction Engineering		10%			\$31,504.00
Administration, Legal, and Bond Counsel		1%			\$3,150.40
Total (Professional Services)					\$34,654.40
<b>Grand Total</b>					<b>\$381,198.40</b>
					\$380,000.00

Project No. Project Description Volume GIS ID No.  
 #2 Northwest Industrial Regional Pond #2 6.7 AC-FT 9

Item	Description	Quantity	Units	Unit Cost	Cost
1	Basin Grading	10882	CY	\$10.00	\$108,820.00
2	Landscaping - Grass	0	SF	\$1.00	\$0.00
3	Seeding	2.3	Acre	\$1,000.00	\$2,250.00
4	Land Acquisition	97923	SF	\$4.00	\$391,692.00
5	Easement Acquisition	0	SF	\$2.50	\$0.00
6	Inlet	1	LS	\$21,000.00	\$21,000.00
7	Spillway	1	LS	\$21,000.00	\$21,000.00
Sub Total (Construction)					\$544,762.00
Contingencies		10%			\$54,476.20
Total (Construction)					\$599,238.20
Design and Construction Engineering		8%			\$43,580.96
Administration, Legal, and Bond Counsel		1%			\$5,447.62
Total (Professional Services)					\$49,028.58
<b>Grand Total</b>					<b>\$648,266.78</b>
					650000

Project No. Project Description Volume GIS ID No.  
**#3 Railroad Corridor Industrial Regional Pond #1 1.0 AC-FT 3**

Item	Description	Quantity	Units	Unit Cost	Cost
1	Basin Grading	1555	CY	\$10.00	\$15,550.00
2	Landscaping - Grass	0	SF	\$1.00	\$0.00
3	Seeding	0.3	Acre	\$1,000.00	\$300.00
4	Land Acquisition	13983	SF	\$4.00	\$55,932.00
5	Easement Acquisition	0	SF	\$2.50	\$0.00
6	Inlet	1	LS	\$14,000.00	\$14,000.00
7	Spillway	1	LS	\$14,000.00	\$14,000.00
Sub Total (Construction)					\$99,782.00
Contingencies					10%
Total (Construction)					\$109,760.20
Design and Construction Engineering					10%
Administration, Legal, and Bond Counsel					1%
Total (Professional Services)					\$10,976.02
<b>Grand Total</b>					<b>\$120,736.22</b>
					120000

Project No. Project Description Volume GIS ID No.  
**#4 Railroad Corridor Industrial Regional Pond #2 3.1 AC-FT 1**

Item	Description	Quantity	Units	Unit Cost	Cost
1	Basin Grading	4945	CY	\$10.00	\$49,450.00
2	Landscaping - Grass	0	SF	\$1.00	\$0.00
3	Seeding	1.0	Acre	\$1,000.00	\$1,000.00
3	Land Acquisition	44518	SF	\$4.00	\$178,072.00
4	Easement Acquisition	0	SF	\$2.50	\$0.00
4	Inlet	1	LS	\$21,000.00	\$21,000.00
5	Spillway	1	LS	\$21,000.00	\$21,000.00
Sub Total (Construction)					\$270,522.00
Contingencies		10%			\$27,052.20
Total (Construction)					\$297,574.20
Design and Construction Engineering		10%			\$27,052.20
Administration, Legal, and Bond Counsel		1%			\$2,705.22
Total (Professional Services)					\$29,757.42
<b>Grand Total</b>					<b>\$327,331.62</b>
					\$330,000.00



Project No. Project Description Volume GIS ID No.  
 #5 Railroad Corridor Industrial Regional Pond #3 3.2 AC-FT 2

Item	Description	Quantity	Units	Unit Cost	Cost
1	Basin Grading	5082	CY	\$10.00	\$50,820.00
2	Landscaping - Grass	0	SF	\$1.00	\$0.00
3	Seeding	1.1	Acre	\$1,000.00	\$1,100.00
3	Land Acquisition	45782	SF	\$4.00	\$183,128.00
4	Easement Acquisition	0	SF	\$2.50	\$0.00
4	Inlet	1	LS	\$21,000.00	\$21,000.00
5	Spillway	1	LS	\$21,000.00	\$21,000.00
Sub Total (Construction)					\$277,048.00
Contingencies					10%
Total (Construction)					\$304,752.80
Design and Construction Engineering					10%
Administration, Legal, and Bond Counsel					1%
Total (Professional Services)					\$30,475.28
<b>Grand Total</b>					<b>\$335,228.08</b>
					\$340,000.00

Project No. Project Description Volume GIS ID No.  
 #6 Summit Creek Reservoir Regional Pond 8.4 AC-FT 12 & 17

Item	Description	Quantity	Units	Unit Cost	Cost
1	Basin Grading	13621	CY	\$10.00	\$136,210.00
2	Landscaping - Grass	122578	SF	\$1.00	\$122,578.00
3	Seeding	0	Acre	\$1,000.00	\$0.00
3	Land Acquisition	122578	SF	\$4.00	\$490,312.00
4	Easement Acquisition	0	SF	\$2.50	\$0.00
4	Inlet	1	LS	\$21,000.00	\$21,000.00
5	Spillway	1	LS	\$21,000.00	\$21,000.00
Sub Total (Construction)					\$791,100.00
Contingencies		10%			\$79,110.00
Total (Construction)					\$870,210.00
Design and Construction Engineering		6%			\$47,466.00
Administration, Legal, and Bond Counsel		1%			\$7,911.00
Total (Professional Services)					\$55,377.00
<b>Grand Total</b>					<b>\$925,587.00</b>
					\$930,000.00

Project No. #7      Project Description Summit Ridge Parkway Regional Pond      Volume 11.0 AC-FT      GIS ID No. 5 & 11

Item	Description	Quantity	Units	Unit Cost	Cost
1	Basin Grading	17764	CY	\$10.00	\$177,640.00
2	Landscaping - Grass	159865	SF	\$1.00	\$159,865.00
3	Land Acquisition*	119899	SF	\$4.00	\$479,596.00
4	Easement Acquisition	0	SF	\$2.50	\$0.00
5	Inlet	1	LS	\$21,000.00	\$21,000.00
6	Spillway	1	LS	\$21,000.00	\$21,000.00
7	Manholes/Inlets/Structures	2	EA	\$6,500.00	\$13,000.00
8	Class "A" Road Repair	585	SF	\$6.00	\$3,510.00
9	Imported Backfill	281	TON	\$12.00	\$3,368.93
10	Pond Interconnections (36" pipe)	120	LF	\$95.00	\$11,400.00
Sub Total (Construction)					\$890,379.93
Contingencies		10%			\$89,037.99
Total (Construction)					\$979,417.92
Design and Construction Engineering		6%			\$53,422.80
Administration, Legal, and Bond Counsel		1%			\$8,903.80
Total (Professional Services)					\$62,326.59
<b>Grand Total</b>					<b>\$1,041,744.52</b>
*1/4 of land assumed to be in existing right-of-way					\$1,040,000.00

#8

**Santaquin Canyon Overflow Channel**

Item	Description	Quantity	Units	Unit Cost	Cost
1	Mobilization	1	LS	----	\$33,628.41
2	15 Inch Storm Drain	0	LF	\$55.00	\$0.00
3	18 Inch Storm Drain	0	LF	\$60.00	\$0.00
4	21 Inch Storm Drain	0	LF	\$65.00	\$0.00
5	24 Inch Storm Drain	0	LF	\$70.00	\$0.00
6	30 Inch Storm Drain	0	LF	\$75.00	\$0.00
7	36 Inch Storm Drain	0	LF	\$95.00	\$0.00
8	42 Inch Storm Drain	0	LF	\$125.00	\$0.00
9	48 Inch Storm Drain	0	LF	\$155.00	\$0.00
10	Spillway	0	EA	\$25,000.00	\$0.00
11	Outlet works	0	EA	\$30,000.00	\$0.00
12	Upper Channel Excavation (6' wide bottom, 3:1 side slopes)	2193	LF	\$16.67	\$36,550.00
13	Upper Channel Access Road Surfacing (12' wide)	487	CY	\$25.00	\$12,175.00
14	Upper Channel Erosion Control (2-ft Deep Riprap)	4057	CY	\$65.00	\$263,694.16
15	Lower Channel Excavation (15' wide bottom, 3:1 side slopes)	4696	LF	\$26.67	\$125,226.67
16	Lower Channel Access Road Surfacing (12'	1044	CY	\$25.00	\$26,100.00
17	Lower Channel Erosion Control (TRM)	17727	SY	\$5.00	\$88,633.52
17	Manholes/Inlets/Structures	2	EA	\$6,500.00	\$13,000.00
	Box Culvert	81	LF	\$1,100.00	\$89,100.00
18	Class "A" Road Repair	0	SF	\$6.00	\$0.00
19	Class "D" Field Repair	-	SF	\$1.00	\$0.00
20	Imported Backfill		TON	\$12.00	\$0.00
21	Railroad and Canal Crossing	0	LS	\$108,000.00	\$0.00
22	State Road Crossing	0	LS	\$220,000.00	\$0.00
23	Traffic Control	1	LS	\$10,000.00	\$10,000.00
24	Utility Relocation (5% of channel cost)	1	LS	\$8,088.83	\$8,088.83
	Sub Total (Construction)				\$706,196.59
	Contingencies	20%			\$141,239.32
	Upper Channel Easement Acquisition (40	87,720	SF	\$4.00	\$350,880.00
	Lower Channel Land Acquisition(50 foot	234,800	SF	\$4.00	\$939,200.00
	Right of Way	-	SF	\$2.00	\$0.00
	Total (Construction)				\$2,137,515.91
	Environmental	5%			\$35,309.83
	Design and Construction Engineering	10%			\$70,619.66
	Administration, Legal, and Bond Counsel	1%			\$7,061.97
	Total (Professional Services)				\$112,991.45
	<b>Grand Total</b>				<b>\$2,250,507.37</b>
					\$2,250,000.00

Santaquin 20%	Difference
\$450,101.47	\$1,800,405.89

#9

**Santaquin Canyon Overflow Channel - I-15 Crossing**

Item	Description	Quantity	Units	Unit Cost	Cost
1	Mobilization	1	LS	----	\$51,736.00
2	15 Inch Storm Drain	0	LF	\$55.00	\$0.00
3	18 Inch Storm Drain	0	LF	\$60.00	\$0.00
4	21 Inch Storm Drain	0	LF	\$65.00	\$0.00
5	24 Inch Storm Drain	0	LF	\$70.00	\$0.00
6	30 Inch Storm Drain	0	LF	\$75.00	\$0.00
7	36 Inch Storm Drain	0	LF	\$95.00	\$0.00
8	42 Inch Storm Drain	0	LF	\$125.00	\$0.00
9	48 Inch Storm Drain	0	LF	\$155.00	\$0.00
10	Spillway	0	EA	\$25,000.00	\$0.00
11	Outlet works	0	EA	\$30,000.00	\$0.00
12	Manholes/Inlets/Structures	2	EA	\$8,000.00	\$16,000.00
13	Box Culvert	537	LF	\$1,100.00	\$590,700.00
14	Class "A" Road Repair	2500	SF	\$6.00	\$15,000.00
15	Class "D" Field Repair	-	SF	\$1.00	\$0.00
16	Imported Backfill		TON	\$12.00	\$0.00
17	Railroad and Canal Crossing	0	LS	\$108,000.00	\$0.00
18	State Road Crossing	0	LS	\$220,000.00	\$0.00
19	Traffic Control	1	LS	\$25,000.00	\$25,000.00
20	Utility Relocation (5% of pipe cost)	0	LS	\$29,535.00	\$0.00
Sub Total (Construction)					\$698,436.00
Contingencies		20%			\$139,687.20
Upper Channel Easement Acquisition (40 foot right-of-way)			SF	\$4.00	\$0.00
Lower Channel Land Acquisition(50 foot right-of-way)			SF	\$4.00	\$0.00
Right of Way		-	SF	\$2.00	\$0.00
Total (Construction)					\$838,123.20
Environmental/PI		5%			\$34,921.80
Design and Construction Engineering		10%			\$69,843.60
Administration, Legal, and Bond Counsel		1%			\$6,984.36
Total (Professional Services)					\$111,749.76
<b>Grand Total</b>					<b>\$949,872.96</b>
					\$950,000.00

Project No.	Project Description	Volume	GIS ID No.		
#10	Western Commercial Regional Pond	3.0 AC-FT	10		
Item	Description	Quantity	Units	Unit Cost	Cost
1	Basin Grading	4916	CY	\$10.00	\$49,160.00
2	Landscaping - Grass	44257	SF	\$1.00	\$44,257.00
3	Land Acquisition*	44257	SF	\$4.00	\$177,028.00
4	Easement Acquisition	0	SF	\$2.50	\$0.00
5	Inlet	1	LS	\$21,000.00	\$21,000.00
6	Spillway	1	LS	\$21,000.00	\$21,000.00
Sub Total (Construction)					\$312,445.00
Contingencies					10%
Total (Construction)					\$343,689.50
Design and Construction Engineering					8%
Administration, Legal, and Bond Counsel					1%
Total (Professional Services)					\$28,120.05
<b>Grand Total</b>					<b>\$371,809.55</b>
					\$370,000.00

Project No. Project Description  
#11 Retention Basin

Volume GIS ID No.  
0.5 AC-FT 15

Item	Description	Quantity	Units	Unit Cost	Cost
1	Basin Grading	820	CY	\$15.00	\$12,300.00
2	Landscaping - Grass	7623	SF	\$1.00	\$7,623.00
3	Basin Land Acquisition	7623	SF	\$8.00	\$60,984.00
4	Pipe Easement Acquisition	10600	SF	\$1.00	\$10,600.00
5	24 Inch Storm Drain	530	LF	\$70.00	\$37,100.00
6	Inlet	1	LS	\$7,500.00	\$7,500.00
7	Spillway	1	LS	\$7,500.00	\$7,500.00
Sub Total (Construction)					\$143,607.00
Contingencies 10%					\$14,360.70
Total (Construction)					\$157,967.70
Design and Construction Engineering 10%					\$14,360.70
Administration, Legal, and Bond Counsel 1%					\$1,436.07
Total (Professional Services)					\$15,796.77
<b>Grand Total</b>					<b>\$173,764.47</b>
					\$170,000.00

#12

## South Mountains Debris Control Structure

2.4 ac-ft Debris Flow Governs

Item	Description	Quantity	Units	Unit Cost	Cost
1	Mobilization	1	LS	----	\$14,285.95
2	15 Inch Storm Drain	0	LF	\$55.00	\$0.00
3	18 Inch Storm Drain	0	LF	\$60.00	\$0.00
4	21 Inch Storm Drain	0	LF	\$65.00	\$0.00
5	24 Inch Storm Drain	0	LF	\$70.00	\$0.00
6	30 Inch Storm Drain	0	LF	\$75.00	\$0.00
7	36 Inch Storm Drain	0	LF	\$95.00	\$0.00
8	42 Inch Storm Drain	0	LF	\$125.00	\$0.00
9	48 Inch Storm Drain	0	LF	\$155.00	\$0.00
	Spillway	1	EA	\$15,000.00	\$15,000.00
	Outlet works	1	EA	\$20,000.00	\$20,000.00
10	Basin Grading	6292	CY	\$12.00	\$75,504.00
11	Manholes/Inlets/Structures	2	EA	\$6,500.00	\$13,000.00
12	Class "A" Road Repair	0	SF	\$6.00	\$0.00
13	Class "D" Field Repair	45,683	SF	\$0.10	\$4,568.31
14	Imported Backfill	1232	TON	\$12.00	\$14,787.23
15	Railroad and Canal Crossing	0	LS	\$108,000.00	\$0.00
16	State Road Crossing	0	LS	\$220,000.00	\$0.00
17	Traffic Control	1	LS	\$0.00	\$0.00
18	Utility Relocation (20% of pipe cost)	1	LS	\$0.00	\$0.00
	Sub Total (Construction)				\$157,145.49
	Contingencies	20%			\$31,429.10
	Land		SF	\$2.00	\$0.00
	Right of Way	45,683	SF	\$1.50	\$68,524.64
	Total (Construction)				\$257,099.23
	Environmental	30%			\$47,143.65
	Design and Construction Engineering	30%			\$47,143.65
	Administration, Legal, and Bond Counsel	1%			\$1,571.45
	Total (Professional Services)				\$95,858.75
	<b>Grand Total</b>				<b>\$352,957.98</b>
					\$350,000.00



## #13

Southeast Bench Debris Control Structure #1 and  
Diversion Channel

10.3 ac-ft 25-year Post-Burn Event Governs

Item	Description	Quantity	Units	Unit Cost	Cost
1	Mobilization	1	LS	----	\$52,871.99
2	15 Inch Storm Drain	0	LF	\$55.00	\$0.00
3	18 Inch Storm Drain	0	LF	\$60.00	\$0.00
4	21 Inch Storm Drain	0	LF	\$65.00	\$0.00
5	24 Inch Storm Drain	0	LF	\$70.00	\$0.00
6	30 Inch Storm Drain	0	LF	\$75.00	\$0.00
7	36 Inch Storm Drain	0	LF	\$95.00	\$0.00
8	42 Inch Storm Drain	0	LF	\$125.00	\$0.00
9	48 Inch Storm Drain	0	LF	\$155.00	\$0.00
10	Channel Excavation (4' wide bottom, 2.5:1 side slopes)	536	LF	\$6.67	\$3,573.33
11	Channel Access Road Surfacing (12' wide)	119	CY	\$25.00	\$2,975.00
12	Channel Erosion Control (1.5' Deep Riprap)	440	CY	\$65.00	\$28,588.79
13	Spillway	1	EA	\$25,000.00	\$25,000.00
14	Outlet works	1	EA	\$30,000.00	\$30,000.00
15	Basin Grading	27003.17	CY	\$12.00	\$324,038.00
16	Toe Drain	1	LS	\$20,000.00	\$20,000.00
17	Manholes/Inlets/Structures	2	EA	\$6,500.00	\$13,000.00
18	Class "A" Road Repair	0	SF	\$6.00	\$0.00
19	Class "D" Field Repair	180,829	SF	\$0.10	\$18,082.89
20	Imported Backfill	5288	TON	\$12.00	\$63,461.85
21	Railroad and Canal Crossing	0	LS	\$108,000.00	\$0.00
22	State Road Crossing	0	LS	\$220,000.00	\$0.00
23	Traffic Control	1	LS	\$0.00	\$0.00
24	Utility Relocation (20% of pipe cost)	1	LS	\$0.00	\$0.00
Sub Total (Construction)					\$581,591.85
Contingencies 20%					\$116,318.37
Land for Debris Basin 180,829 SF \$1.25					\$226,036.13
Land for Channel 13,400 SF \$1.25					\$16,750.00
Right of Way - SF \$0.63					\$0.00
Total (Construction)					\$940,696.36
Environmental 10%					\$58,159.19
Design and Construction Engineering 15%					\$87,238.78
Administration, Legal, and Bond Counsel 1%					\$5,815.92
Total (Professional Services)					\$151,213.88
<b>Grand Total</b>					<b>\$1,091,910.24</b>
					\$1,090,000.00

#14

**Southeast Bench Debris Control Structure #2**

2.6 ac-ft Debris Flow Governs

Item	Description	Quantity	Units	Unit Cost	Cost
1	Mobilization	1	LS	----	\$15,076.45
2	15 Inch Storm Drain	0	LF	\$55.00	\$0.00
3	18 Inch Storm Drain	0	LF	\$60.00	\$0.00
4	21 Inch Storm Drain	0	LF	\$65.00	\$0.00
5	24 Inch Storm Drain	0	LF	\$70.00	\$0.00
6	30 Inch Storm Drain	0	LF	\$75.00	\$0.00
7	36 Inch Storm Drain	0	LF	\$95.00	\$0.00
8	42 Inch Storm Drain	0	LF	\$125.00	\$0.00
9	48 Inch Storm Drain	0	LF	\$155.00	\$0.00
	Spillway	1	EA	\$15,000.00	\$15,000.00
	Outlet works	1	EA	\$20,000.00	\$20,000.00
10	Basin Grading	6816.333	CY	\$12.00	\$81,796.00
11	Manholes/Inlets/Structures	2	EA	\$6,500.00	\$13,000.00
12	Class "A" Road Repair	0	SF	\$6.00	\$0.00
13	Class "D" Field Repair	49,490	SF	\$0.10	\$4,949.00
14	Imported Backfill	1335	TON	\$12.00	\$16,019.50
15	Railroad and Canal Crossing	0	LS	\$108,000.00	\$0.00
16	State Road Crossing	0	LS	\$220,000.00	\$0.00
17	Traffic Control	1	LS	\$0.00	\$0.00
18	Utility Relocation (20% of pipe cost)	1	LS	\$0.00	\$0.00
	Sub Total (Construction)				\$165,840.95
	Contingencies	20%			\$33,168.19
	Land	49,490	SF	\$2.00	\$98,980.03
	Right of Way	-	SF	\$1.00	\$0.00
	Total (Construction)				\$297,989.17
	Environmental	5%			\$8,292.05
	Design and Construction Engineering	25%			\$41,460.24
	Administration, Legal, and Bond Counsel	1%			\$1,658.41
	Total (Professional Services)				\$51,410.69
	<b>Grand Total</b>				<b>\$349,399.86</b>
					\$350,000.00

#15

**Spring Lake Debris Control Structure #1**

4.6 ac-ft 25-year Post-Burn Event Governs

Item	Description	Quantity	Units	Unit Cost	Cost
1	Mobilization	1	LS	----	\$25,279.35
2	15 Inch Storm Drain	0	LF	\$55.00	\$0.00
3	18 Inch Storm Drain	0	LF	\$60.00	\$0.00
4	21 Inch Storm Drain	0	LF	\$65.00	\$0.00
5	24 Inch Storm Drain	0	LF	\$70.00	\$0.00
6	30 Inch Storm Drain	0	LF	\$75.00	\$0.00
7	36 Inch Storm Drain	0	LF	\$95.00	\$0.00
8	42 Inch Storm Drain	0	LF	\$125.00	\$0.00
9	48 Inch Storm Drain	0	LF	\$155.00	\$0.00
10	Spillway	1	EA	\$20,000.00	\$20,000.00
11	Outlet works	1	EA	\$25,000.00	\$25,000.00
12	Basin Grading	12059.67	CY	\$12.00	\$144,716.00
12	Manholes/Inlets/Structures	2	EA	\$6,500.00	\$13,000.00
13	Toe Drain	1	LS	\$15,000.00	\$15,000.00
14	Class "A" Road Repair	0	SF	\$6.00	\$0.00
15	Class "D" Field Repair	67,353	SF	\$0.10	\$6,735.33
16	Imported Backfill	2362	TON	\$12.00	\$28,342.18
17	Railroad and Canal Crossing	0	LS	\$108,000.00	\$0.00
18	State Road Crossing	0	LS	\$220,000.00	\$0.00
19	Traffic Control	1	LS	\$0.00	\$0.00
20	Utility Relocation (20% of pipe cost)	1	LS	\$0.00	\$0.00
Sub Total (Construction)					\$278,072.86
Contingencies					20%
					\$55,614.57
Land					67,353 SF
					\$2.00
Right of Way					- SF
					\$1.00
Total (Construction)					\$468,393.99
Environmental					5%
					\$13,903.64
Design and Construction Engineering					25%
					\$69,518.22
Administration, Legal, and Bond Counsel					1%
					\$2,780.73
Total (Professional Services)					\$86,202.59
<b>Grand Total</b>					<b>\$554,596.58</b>
					\$550,000.00

## #16

## Spring Lake Debris Control Structure #2

12.1 ac-ft 25-yr Post-Burn Governs

Item	Description	Quantity	Units	Unit Cost	Cost
1	Mobilization	1	LS	----	\$56,625.02
2	15 Inch Storm Drain	0	LF	\$55.00	\$0.00
3	18 Inch Storm Drain	0	LF	\$60.00	\$0.00
4	21 Inch Storm Drain	0	LF	\$65.00	\$0.00
5	24 Inch Storm Drain	0	LF	\$70.00	\$0.00
6	30 Inch Storm Drain	0	LF	\$75.00	\$0.00
7	36 Inch Storm Drain	0	LF	\$95.00	\$0.00
8	42 Inch Storm Drain	0	LF	\$125.00	\$0.00
9	48 Inch Storm Drain	0	LF	\$155.00	\$0.00
10	Spillway	1	EA	\$25,000.00	\$25,000.00
11	Outlet works	1	EA	\$30,000.00	\$30,000.00
12	Basin Grading	31722.17	CY	\$12.00	\$380,666.00
13	Toe Drain	1	LS	\$20,000.00	\$20,000.00
14	Manholes/Inlets/Structures	2	EA	\$6,500.00	\$13,000.00
15	Class "A" Road Repair	0	SF	\$6.00	\$0.00
16	Class "D" Field Repair	230,319	SF	\$0.10	\$23,031.89
17	Imported Backfill	6213	TON	\$12.00	\$74,552.27
18	Railroad and Canal Crossing	0	LS	\$108,000.00	\$0.00
19	State Road Crossing	0	LS	\$220,000.00	\$0.00
20	Traffic Control	1	LS	\$0.00	\$0.00
21	Utility Relocation (20% of pipe cost)	1	LS	\$0.00	\$0.00
Sub Total (Construction)					\$622,875.18
Contingencies 20%					\$124,575.04
Land 230,319 SF \$2.00					\$460,637.85
Right of Way - SF \$1.00					\$0.00
Total (Construction)					\$1,208,088.06
Environmental 5%					\$31,143.76
Design and Construction Engineering 25%					\$155,718.79
Administration, Legal, and Bond Counsel 1%					\$6,228.75
Total (Professional Services)					\$193,091.31
<b>Grand Total</b>					<b>\$1,401,179.37</b>
					\$1,400,000.00

## APPENDIX F – STORM DISTRIBUTIONS

- NOAA Storm Distribution

**NOAA Atlas 14 Temporal Distributions**

First Quartile		6 Hour	
% of duration	Hour	6hr-20% General	6hr-50% General
0	0	0	0
8.3	0.0000	24.1	28.3
16.7	1.0000	52.1	49.2
25.0	1.3118	79.2	67.1
33.3	2.0000	89.8	81.1
41.7	2.5000	94.8	85.3
50.0	3	97.2	93.7
58.3	3.4999	98.4	96.1
66.7	4.0000	99.1	97.5
75.0	4.5	99.5	98.4
83.3	4.9999	99.8	99.1
91.7	5.5000	99.9	99.5
100.0	6	100	100

First Quartile		12 Hour	
% of duration	Hour	12hr-20% General	12hr-50% General
0	0	0	0
8.3	0.0000	29.9	34.1
16.7	2.0000	49.9	54.4
25.0	2.7772	66.4	71.9
33.3	3.5000	81.4	87.4
41.7	5.0000	88.1	89.8
50.0	6	93.5	94.4
58.3	6.9999	94.8	95.8
66.7	8.0000	96	97.1
75.0	9	96.8	98.4
83.3	9.9999	97.9	99
91.7	11.0000	98.4	99.4
100.0	12	100	100

First Quartile		24 Hour	
% of duration	Hour	24hr-20% General	24hr-50% General
0	0	0	0
8.3	1.0000	38.5	44.9
16.7	4.0000	64	69.3
25.0	6	78.6	84.3
33.3	7.9999	87.8	91.6
41.7	10.0000	93.3	96.3
50.0	12	96.8	99.3
58.3	13.9999	98.2	99.8
66.7	16.0000	99.1	99.8
75.0	18	99.8	99.9
83.3	19.9999	99.9	99.9
91.7	22.0000	100	99.9
100.0	24	100	100

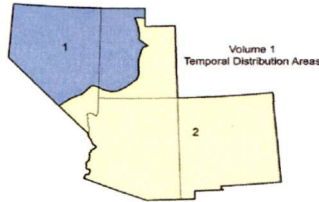
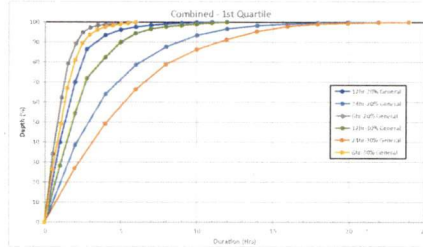
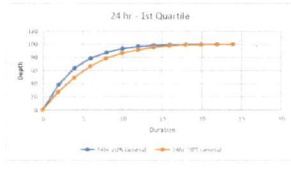
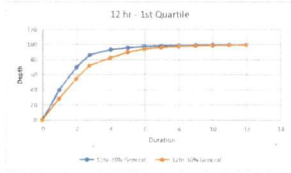
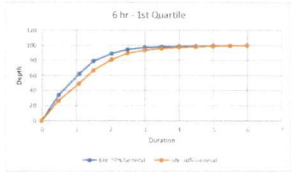

**Temporal Distributions for 6-, 12-, 24- and 96-hour Durations**

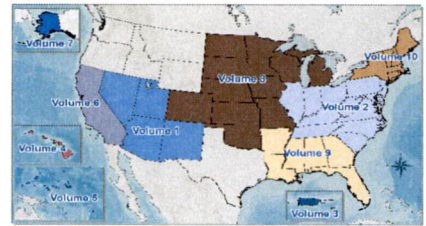

(Click on the map to display the temporal distribution areas for each Volume.)  
 Temporal distributions of precipitation amounts exceeding precipitation frequency estimates for the 2-year average recurrence interval are provided for 6-, 12-, 24-, and 96-hour durations. The temporal distributions are expressed in probability terms as cumulative percentages of precipitation totals at various time steps. To provide detailed information on the varying temporal distributions, separate temporal distributions were also derived for four precipitation classes defined by the duration quartile in which the greatest percentage of the total precipitation occurred. Unique temporal distributions were derived for each temporal distribution area, which were delineated based on selected extreme precipitation characteristics (see documentation for more details).

**DOWNLOAD TEMPORAL DISTRIBUTIONS:**  
 Temporal distributions for 6-, 12-, 24- and 96-hour durations can be downloaded as comma-delimited files for each temporal distribution area.

Volume:

Temporal distribution area (see map above):

Duration:

## APPENDIX G – PRECIPITATION DATA

- Precipitation Depths Comparison
- NOAA Atlas 14 Santaquin Chlorinator Station Precipitation Data
- NOAA Atlas 14 East Mountains Precipitation Data

**Santaquin Rainfall Depths - NOAA Precipitation Data Server**

Location	25-Year			100-Year			Point Definition		
	6-Hour	12-Hour	24-Hour	6-Hour	12-Hour	24-Hour	Latitude	Longitude	Elevation
Downtown Santaquin	1.59	1.94	2.46	2.08	2.42	2.99	39.975	-111.7787	4955.15
Santaquin South (Foothills)	1.58	1.92	2.49	2.07	2.39	3.02	39.9376	-111.7992	5540.05
South Mountains (Pole Canyon)	1.64	2.02	2.59	2.15	2.51	3.15	39.9311	-111.775	5991.64
Santaquin East Mountains	1.65	2.04	2.53	2.17	2.55	3.07	39.9766	-111.7328	7659.61
Overall Average	1.62	1.98	2.52	2.12	2.47	3.06			
Lower Elevation Average	1.59	1.93	2.48	2.08	2.41	3.01			
Upper Elevation Average	1.65	2.03	2.56	2.16	2.53	3.11			
Difference Upper v. Lower	0.06	0.10	0.08	0.09	0.13	0.11			
Std. Dev.	0.03	0.05	0.05	0.04	0.06	0.06			
<b>Recommendation</b>									
Santaquin Chlorinator Station	1.59	1.94	2.50	2.08	2.42	3.03	39.9578	111.7794	5160
Santaquin East Mountains (Over 6000 ft)	1.65	2.04	2.55	2.16	2.54	3.10	39.9633	111.744	6657.78

For General Use in City  
For Use in Watersheds whose centroid lies above 6000 feet

Downtown



Santaquin East Mountains



South Santaquin (Foothills)



South Mountains (Pole Canyon)

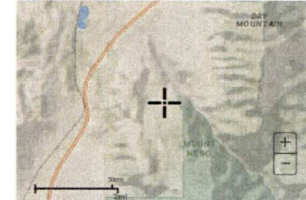

**Recommended Stations:**

Santaquin East Mountains (Over 6000 feet)

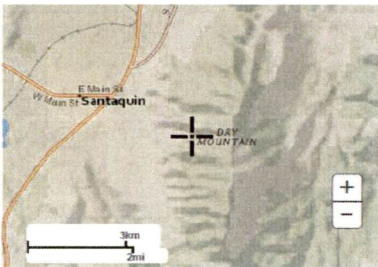

Santaquin Chlorinator Station (Actual Precipitation Gauge Station)





NOAA Atlas 14, Volume 1, Version 5 SANTAQUIN

CHLORINATOR

Station ID: 42-7686

Location name: Santaquin, Utah, USA\*

Latitude: 39.9578°, Longitude: -111.7794°

Elevation:

Elevation (station metadata): 5160 ft\*\*

\* source: ESRI Maps

\*\* source: USGS



POINT PRECIPITATION FREQUENCY ESTIMATES

Sanja Perica, Sarah Dietz, Sarah Heim, Lillian Hiner, Kazungu Maitania, Deborah Martin, Sandra Pavlovic, Ishani Roy, Carl Trypaluk, Dale Unruh, Fenglin Yan, Michael Yekta, Tan Zhao, Geoffrey Bonnin, Daniel Brewer, Li-Chuan Chen, Tye Parzybok, John Yarchoan

NOAA, National Weather Service, Silver Spring, Maryland

[PF tabular](#) | [PF graphical](#) | [Maps & aeriels](#)

PF tabular

PDS-based point precipitation frequency estimates with 90% confidence intervals (in inches) <sup>1</sup>										
Duration	Average recurrence interval (years)									
	1	2	5	10	25	50	100	200	500	1000
5-min	0.128 (0.111-0.150)	0.163 (0.142-0.193)	0.226 (0.194-0.266)	0.281 (0.239-0.333)	0.366 (0.304-0.435)	0.443 (0.360-0.529)	0.531 (0.422-0.638)	0.632 (0.488-0.769)	0.794 (0.584-0.983)	0.938 (0.665-1.18)
10-min	0.194 (0.168-0.228)	0.248 (0.215-0.293)	0.343 (0.295-0.405)	0.427 (0.364-0.506)	0.557 (0.463-0.662)	0.674 (0.548-0.804)	0.808 (0.642-0.971)	0.963 (0.742-1.17)	1.21 (0.889-1.50)	1.43 (1.01-1.80)
15-min	0.240 (0.208-0.283)	0.308 (0.267-0.363)	0.426 (0.366-0.502)	0.530 (0.451-0.628)	0.690 (0.574-0.821)	0.835 (0.680-0.997)	1.00 (0.796-1.20)	1.19 (0.920-1.45)	1.50 (1.10-1.85)	1.77 (1.25-2.23)
30-min	0.323 (0.280-0.382)	0.414 (0.359-0.489)	0.573 (0.493-0.677)	0.713 (0.608-0.845)	0.930 (0.773-1.10)	1.12 (0.916-1.34)	1.35 (1.07-1.62)	1.61 (1.24-1.95)	2.02 (1.49-2.50)	2.38 (1.69-3.00)
60-min	0.400 (0.347-0.472)	0.513 (0.445-0.606)	0.709 (0.610-0.837)	0.883 (0.752-1.05)	1.15 (0.957-1.37)	1.39 (1.13-1.66)	1.67 (1.33-2.01)	1.99 (1.53-2.42)	2.50 (1.84-3.09)	2.95 (2.09-3.72)
2-hr	0.503 (0.446-0.582)	0.635 (0.558-0.733)	0.838 (0.734-0.972)	1.02 (0.886-1.19)	1.31 (1.11-1.53)	1.57 (1.30-1.84)	1.87 (1.51-2.21)	2.21 (1.74-2.65)	2.76 (2.07-3.36)	3.25 (2.35-4.05)
3-hr	0.579 (0.519-0.659)	0.723 (0.648-0.824)	0.924 (0.825-1.05)	1.11 (0.979-1.26)	1.39 (1.21-1.59)	1.63 (1.39-1.88)	1.93 (1.61-2.24)	2.27 (1.85-2.67)	2.82 (2.21-3.39)	3.31 (2.50-4.07)
6-hr	0.752 (0.684-0.839)	0.930 (0.844-1.04)	1.14 (1.03-1.28)	1.33 (1.20-1.49)	1.59 (1.41-1.78)	1.82 (1.59-2.06)	2.08 (1.79-2.38)	2.40 (2.03-2.77)	2.93 (2.41-3.45)	3.40 (2.74-4.08)
12-hr	0.965 (0.882-1.06)	1.19 (1.08-1.31)	1.44 (1.31-1.59)	1.65 (1.49-1.82)	1.94 (1.74-2.15)	2.17 (1.93-2.43)	2.42 (2.12-2.72)	2.71 (2.34-3.09)	3.20 (2.71-3.71)	3.63 (3.02-4.26)
24-hr	1.27 (1.20-1.36)	1.57 (1.47-1.68)	1.89 (1.77-2.02)	2.15 (2.01-2.29)	2.50 (2.33-2.67)	2.77 (2.56-2.96)	3.03 (2.81-3.25)	3.30 (3.03-3.54)	3.66 (3.34-3.95)	3.94 (3.56-4.29)
2-day	1.43 (1.34-1.53)	1.76 (1.64-1.89)	2.13 (1.99-2.28)	2.43 (2.27-2.60)	2.85 (2.65-3.06)	3.18 (2.94-3.41)	3.53 (3.25-3.79)	3.88 (3.55-4.18)	4.37 (3.95-4.72)	4.74 (4.26-5.17)
3-day	1.58 (1.48-1.69)	1.94 (1.82-2.08)	2.36 (2.21-2.54)	2.71 (2.53-2.91)	3.20 (2.98-3.44)	3.59 (3.32-3.86)	4.00 (3.68-4.30)	4.42 (4.05-4.77)	5.00 (4.53-5.43)	5.47 (4.90-5.96)
4-day	1.72 (1.62-1.85)	2.12 (1.99-2.28)	2.60 (2.43-2.79)	2.99 (2.80-3.22)	3.55 (3.31-3.82)	4.00 (3.71-4.31)	4.46 (4.12-4.82)	4.96 (4.55-5.37)	5.64 (5.11-6.13)	6.19 (5.55-6.76)
7-day	2.00 (1.88-2.14)	2.47 (2.32-2.65)	3.01 (2.81-3.22)	3.44 (3.21-3.68)	4.05 (3.77-4.34)	4.54 (4.20-4.86)	5.03 (4.63-5.41)	5.54 (5.07-5.98)	6.23 (5.64-6.77)	6.77 (6.07-7.39)
10-day	2.27 (2.13-2.42)	2.80 (2.62-2.98)	3.38 (3.16-3.60)	3.85 (3.60-4.11)	4.48 (4.17-4.78)	4.97 (4.61-5.30)	5.46 (5.04-5.83)	5.95 (5.47-6.38)	6.61 (6.01-7.12)	7.13 (6.44-7.69)
20-day	3.05 (2.88-3.23)	3.76 (3.56-4.00)	4.50 (4.26-4.78)	5.08 (4.79-5.38)	5.83 (5.50-6.18)	6.39 (6.00-6.77)	6.93 (6.49-7.36)	7.47 (6.96-7.95)	8.15 (7.55-8.72)	8.66 (7.98-9.29)
30-day	3.65 (3.44-3.87)	4.50 (4.25-4.78)	5.38 (5.09-5.72)	6.09 (5.76-6.47)	7.04 (6.63-7.48)	7.76 (7.28-8.25)	8.48 (7.91-9.03)	9.19 (8.53-9.81)	10.1 (9.32-10.9)	10.8 (9.90-11.7)
45-day	4.63 (4.38-4.89)	5.69 (5.39-6.02)	6.75 (6.40-7.14)	7.59 (7.19-8.03)	8.68 (8.18-9.19)	9.49 (8.92-10.1)	10.3 (9.63-10.9)	11.1 (10.3-11.8)	12.1 (11.2-12.9)	12.8 (11.8-13.8)
60-day	5.55 (5.25-5.87)	6.83 (6.46-7.23)	8.09 (7.64-8.54)	9.06 (8.55-9.57)	10.3 (9.70-10.9)	11.2 (10.5-11.8)	12.1 (11.3-12.8)	12.9 (12.1-13.7)	14.0 (13.0-14.9)	14.8 (13.7-15.8)

<sup>1</sup> Precipitation frequency (PF) estimates in this table are based on frequency analysis of partial duration series (PDS). Numbers in parenthesis are PF estimates at lower and upper bounds of the 90% confidence interval. The probability that precipitation frequency estimates (for a given duration and average recurrence interval) will be greater than the upper bound (or less than the lower bound) is 5%. Estimates at upper bounds are not checked against probable maximum precipitation (PMP) estimates and may be higher than currently valid PMP values. Please refer to NOAA Atlas 14 document for more information.

[Back to Top](#)

PF graphical

PDS-based depth-duration-frequency (DDF) curves  
 Latitude: 39.9578°, Longitude: -111.7794°

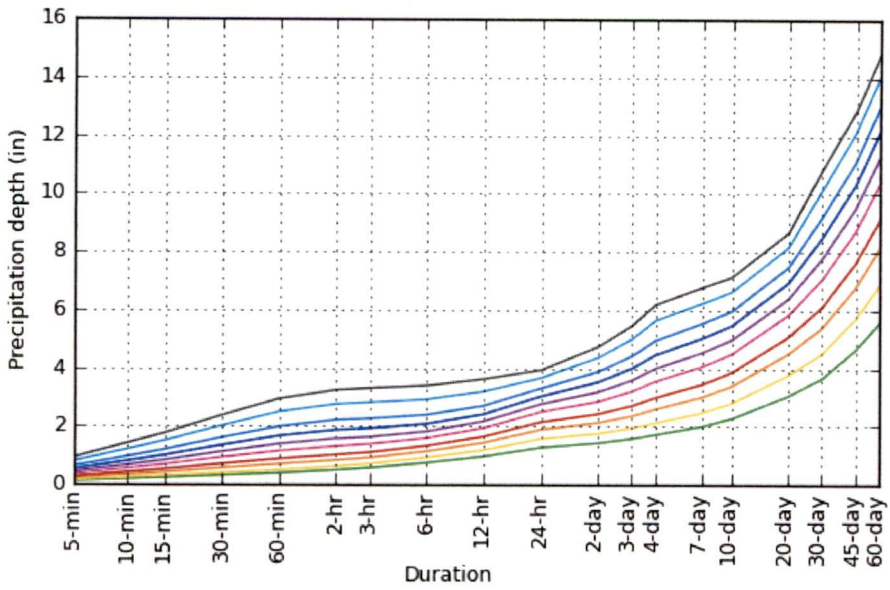

Average recurrence interval (years)
1
2
5
10
25
50
100
200
500
1000

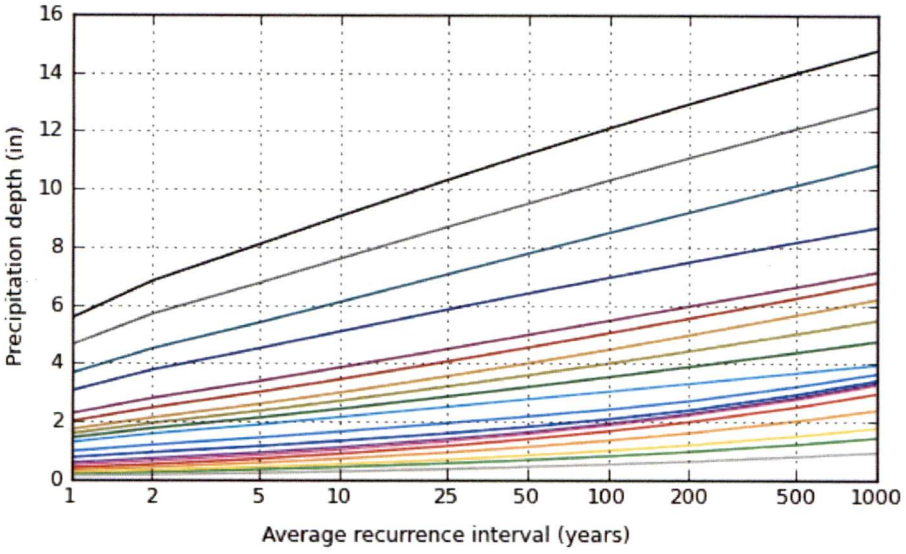

Duration
5-min
10-min
15-min
30-min
60-min
2-hr
3-hr
6-hr
12-hr
24-hr
2-day
3-day
4-day
7-day
10-day
20-day
30-day
45-day
60-day

[Back to Top](#)

**Maps & aeriels**

Small scale terrain

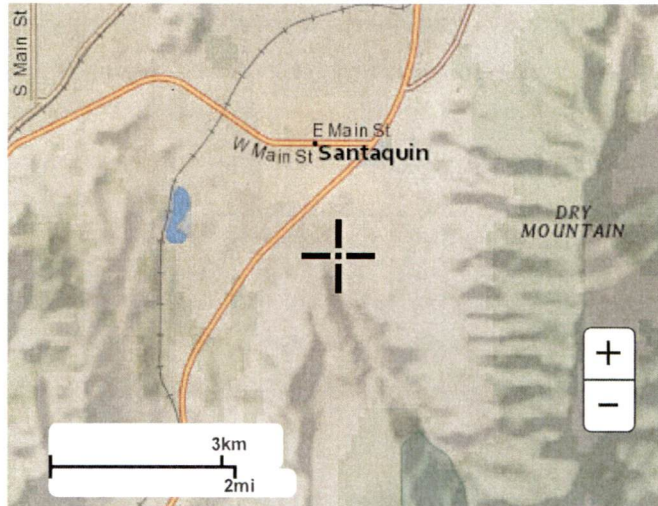

Large scale terrain

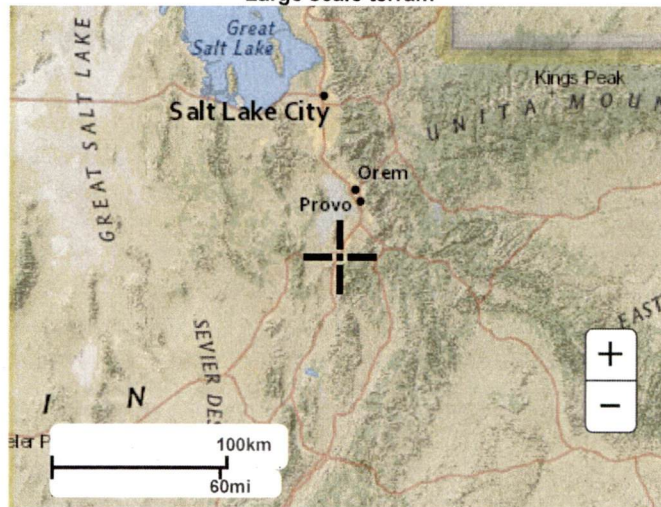

Large scale map

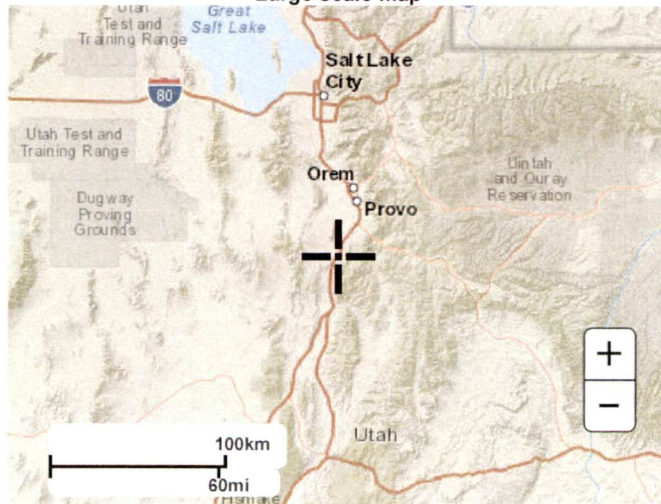

Large scale aerial

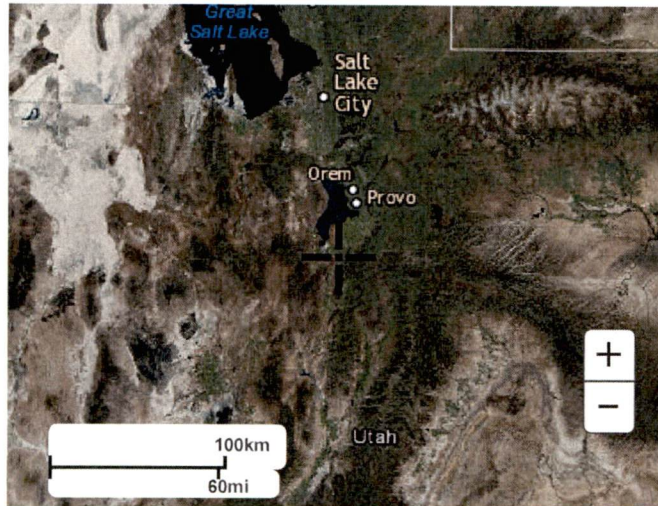

[Back to Top](#)

---

[US Department of Commerce](#)  
[National Oceanic and Atmospheric Administration](#)  
[National Weather Service](#)  
[National Water Center](#)  
1325 East West Highway  
Silver Spring, MD 20910  
Questions?: [HDSC.Questions@noaa.gov](mailto:HDSC.Questions@noaa.gov)

[Disclaimer](#)



**NOAA Atlas 14, Volume 1, Version 5**  
**Location name: Santaquin, Utah, USA\***  
**Latitude: 39.9633°, Longitude: -111.744°**  
**Elevation: 6657.78 ft\*\***  
 \* source: ESRI Maps  
 \*\* source: USGS



**POINT PRECIPITATION FREQUENCY ESTIMATES**

Sanja Perica, Sarah Dietz, Sarah Heim, Lillian Hiner, Kazungu Maitaria, Deborah Martin, Sandra Pavlovic, Ishani Roy, Carl Trypaluk, Dale Unruh, Fenglin Yan, Michael Yekta, Tan Zhao, Geoffrey Bonnin, Daniel Brewer, Li-Chuan Chen, Tye Parzybok, John Yarchoan

NOAA, National Weather Service, Silver Spring, Maryland

[PF\\_tabular](#) | [PF\\_graphical](#) | [Maps & aerials](#)

**PF tabular**

<b>PDS-based point precipitation frequency estimates with 90% confidence intervals (in inches)<sup>1</sup></b>										
Duration	Average recurrence interval (years)									
	1	2	5	10	25	50	100	200	500	1000
5-min	0.131 (0.114-0.155)	0.168 (0.146-0.199)	0.232 (0.199-0.274)	0.288 (0.245-0.342)	0.376 (0.312-0.447)	0.453 (0.368-0.542)	0.543 (0.431-0.654)	0.647 (0.498-0.788)	0.812 (0.597-1.01)	0.960 (0.679-1.21)
10-min	0.200 (0.173-0.236)	0.256 (0.222-0.303)	0.353 (0.303-0.418)	0.439 (0.373-0.521)	0.571 (0.474-0.680)	0.689 (0.561-0.825)	0.826 (0.656-0.995)	0.985 (0.758-1.20)	1.24 (0.908-1.53)	1.46 (1.03-1.84)
15-min	0.248 (0.215-0.293)	0.317 (0.275-0.375)	0.437 (0.376-0.518)	0.544 (0.463-0.646)	0.708 (0.588-0.843)	0.855 (0.695-1.02)	1.02 (0.814-1.23)	1.22 (0.940-1.49)	1.53 (1.13-1.90)	1.81 (1.28-2.29)
30-min	0.334 (0.289-0.394)	0.426 (0.370-0.505)	0.589 (0.506-0.697)	0.732 (0.623-0.869)	0.954 (0.792-1.14)	1.15 (0.936-1.38)	1.38 (1.10-1.66)	1.64 (1.26-2.00)	2.06 (1.52-2.56)	2.44 (1.73-3.08)
60-min	0.413 (0.358-0.488)	0.528 (0.458-0.625)	0.729 (0.626-0.863)	0.906 (0.771-1.08)	1.18 (0.980-1.41)	1.42 (1.16-1.71)	1.71 (1.36-2.06)	2.04 (1.57-2.48)	2.55 (1.88-3.17)	3.02 (2.13-3.81)
2-hr	0.521 (0.460-0.604)	0.656 (0.578-0.760)	0.865 (0.758-1.00)	1.05 (0.913-1.22)	1.35 (1.14-1.57)	1.61 (1.34-1.90)	1.92 (1.55-2.28)	2.27 (1.78-2.73)	2.83 (2.12-3.46)	3.34 (2.41-4.17)
3-hr	0.604 (0.540-0.689)	0.753 (0.673-0.860)	0.959 (0.854-1.10)	1.15 (1.01-1.31)	1.44 (1.25-1.65)	1.69 (1.43-1.95)	1.99 (1.66-2.32)	2.34 (1.90-2.77)	2.91 (2.27-3.51)	3.42 (2.58-4.21)
6-hr	0.789 (0.715-0.881)	0.972 (0.881-1.09)	1.19 (1.07-1.33)	1.38 (1.24-1.54)	1.65 (1.46-1.86)	1.89 (1.65-2.14)	2.16 (1.86-2.48)	2.49 (2.11-2.88)	3.04 (2.50-3.58)	3.53 (2.84-4.24)
12-hr	1.02 (0.930-1.13)	1.25 (1.14-1.38)	1.51 (1.37-1.67)	1.73 (1.57-1.92)	2.04 (1.83-2.27)	2.28 (2.02-2.56)	2.54 (2.23-2.87)	2.85 (2.46-3.25)	3.37 (2.85-3.90)	3.82 (3.17-4.49)
24-hr	1.30 (1.21-1.40)	1.60 (1.48-1.73)	1.92 (1.79-2.08)	2.19 (2.03-2.36)	2.55 (2.35-2.75)	2.83 (2.60-3.05)	3.10 (2.84-3.36)	3.38 (3.08-3.67)	3.75 (3.39-4.08)	4.04 (3.62-4.53)
2-day	1.48 (1.38-1.60)	1.82 (1.69-1.97)	2.21 (2.05-2.39)	2.54 (2.34-2.74)	2.98 (2.75-3.23)	3.34 (3.05-3.61)	3.71 (3.38-4.02)	4.09 (3.70-4.44)	4.62 (4.13-5.04)	5.03 (4.46-5.52)
3-day	1.65 (1.53-1.78)	2.03 (1.89-2.20)	2.48 (2.29-2.69)	2.85 (2.63-3.10)	3.38 (3.11-3.67)	3.80 (3.48-4.13)	4.24 (3.86-4.62)	4.71 (4.25-5.13)	5.34 (4.77-5.86)	5.85 (5.17-6.45)
4-day	1.81 (1.68-1.97)	2.24 (2.08-2.43)	2.74 (2.54-2.99)	3.17 (2.93-3.45)	3.78 (3.48-4.12)	4.26 (3.90-4.65)	4.78 (4.34-5.22)	5.32 (4.80-5.82)	6.07 (5.41-6.67)	6.68 (5.89-7.37)
7-day	2.13 (1.98-2.31)	2.63 (2.45-2.85)	3.22 (2.99-3.49)	3.71 (3.43-4.01)	4.38 (4.04-4.74)	4.92 (4.51-5.33)	5.47 (4.99-5.95)	6.05 (5.47-6.59)	6.83 (6.12-7.49)	7.46 (6.61-8.21)
10-day	2.43 (2.27-2.62)	3.00 (2.80-3.23)	3.64 (3.38-3.92)	4.16 (3.86-4.48)	4.86 (4.49-5.24)	5.41 (4.97-5.83)	5.96 (5.46-6.44)	6.52 (5.94-7.07)	7.28 (6.56-7.93)	7.88 (7.04-8.60)
20-day	3.32 (3.10-3.55)	4.10 (3.83-4.39)	4.92 (4.60-5.27)	5.56 (5.19-5.96)	6.40 (5.96-6.86)	7.03 (6.52-7.54)	7.65 (7.07-8.22)	8.27 (7.61-8.91)	9.07 (8.29-9.82)	9.66 (8.78-10.5)
30-day	4.01 (3.76-4.29)	4.95 (4.64-5.30)	5.95 (5.57-6.38)	6.75 (6.31-7.24)	7.83 (7.29-8.39)	8.64 (8.02-9.29)	9.47 (8.74-10.2)	10.3 (9.45-11.1)	11.4 (10.4-12.4)	12.2 (11.0-13.3)
45-day	5.08 (4.76-5.42)	6.25 (5.86-6.68)	7.44 (6.97-7.96)	8.39 (7.84-8.98)	9.63 (8.97-10.3)	10.6 (9.80-11.3)	11.5 (10.6-12.4)	12.4 (11.4-13.4)	13.6 (12.4-14.8)	14.6 (13.2-15.9)
60-day	6.11 (5.72-6.51)	7.53 (7.06-8.05)	8.95 (8.38-9.56)	10.0 (9.39-10.7)	11.5 (10.7-12.3)	12.5 (11.6-13.4)	13.5 (12.5-14.5)	14.5 (13.4-15.6)	15.8 (14.5-17.0)	16.7 (15.2-18.1)

<sup>1</sup> Precipitation frequency (PF) estimates in this table are based on frequency analysis of partial duration series (PDS). Numbers in parenthesis are PF estimates at lower and upper bounds of the 90% confidence interval. The probability that precipitation frequency estimates (for a given duration and average recurrence interval) will be greater than the upper bound (or less than the lower bound) is 5%. Estimates at upper bounds are not checked against probable maximum precipitation (PMP) estimates and may be higher than currently valid PMP values. Please refer to NOAA Atlas 14 document for more information.

[Back to Top](#)

**PF graphical**

PDS-based depth-duration-frequency (DDF) curves  
 Latitude: 39.9633°, Longitude: -111.7440°

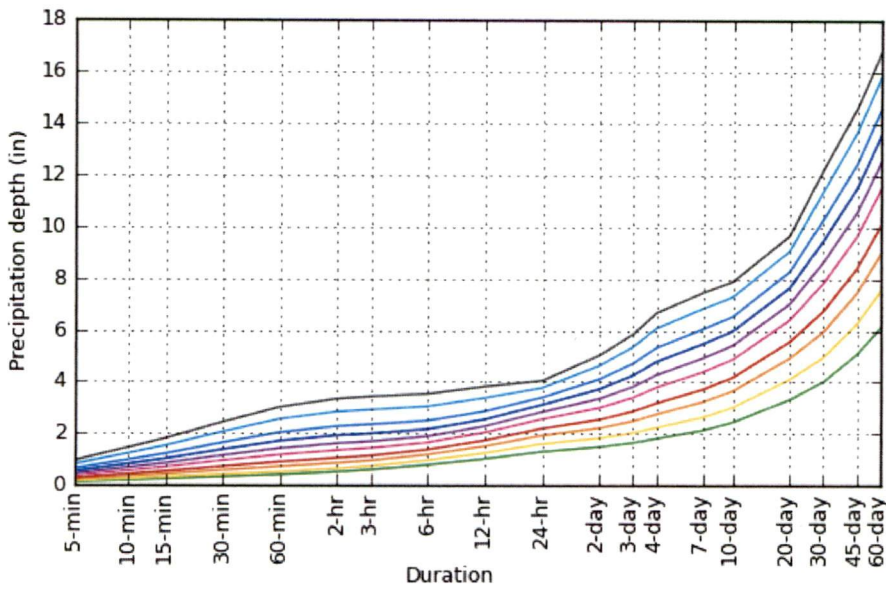

Average recurrence interval (years)
1
2
5
10
25
50
100
200
500
1000

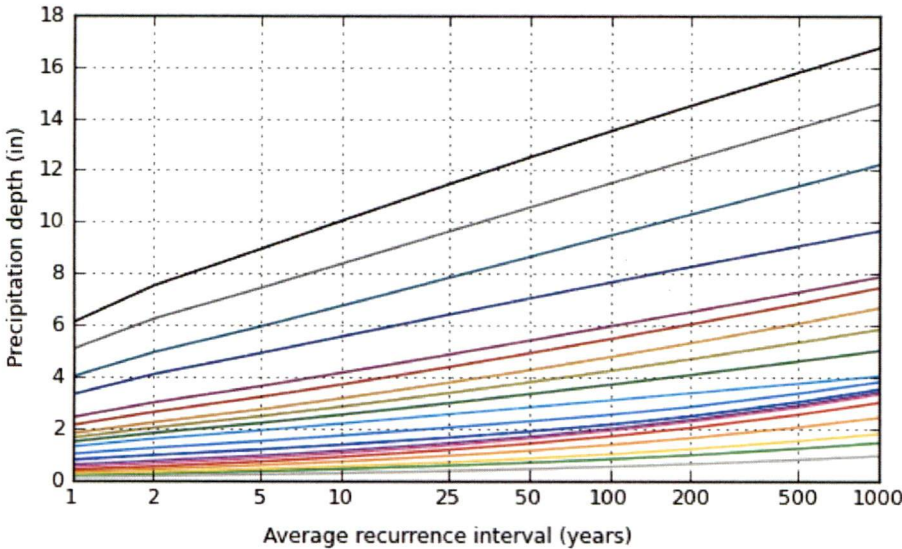

Duration	
5-min	2-day
10-min	3-day
15-min	4-day
30-min	7-day
60-min	10-day
2-hr	20-day
3-hr	30-day
6-hr	45-day
12-hr	60-day
24-hr	

[Back to Top](#)

**Maps & aerials**

Small scale terrain

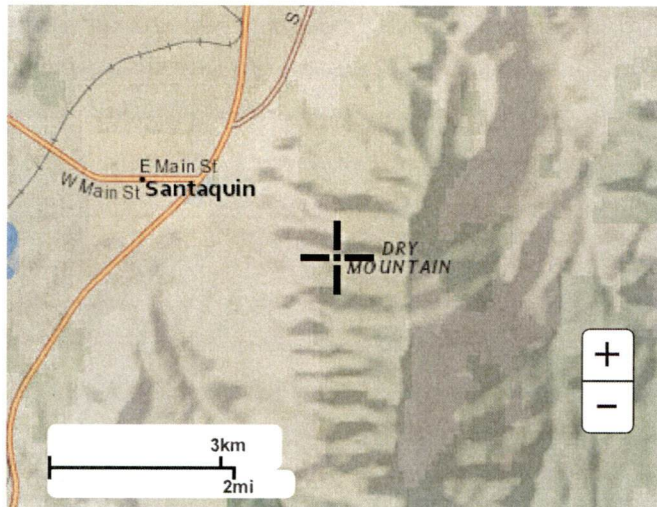

Large scale terrain

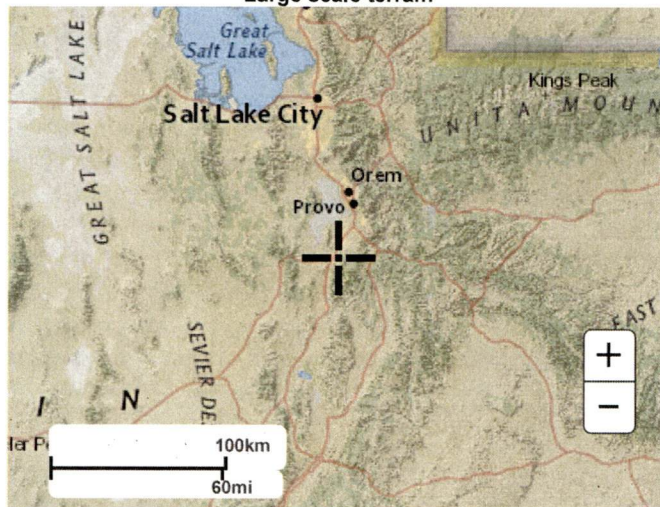

Large scale map

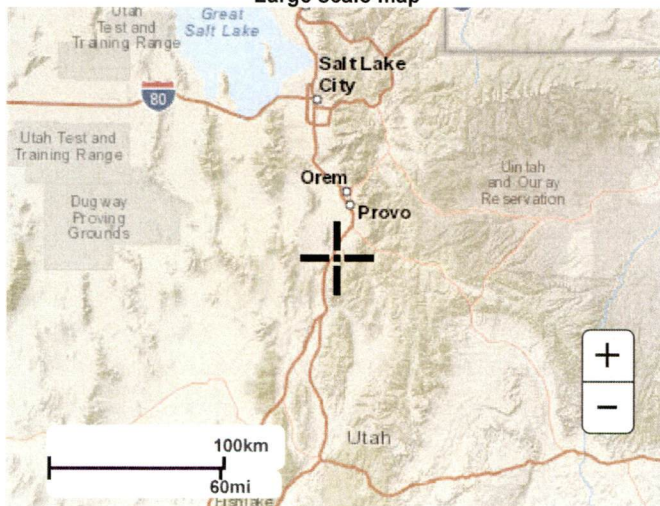

Large scale aerial

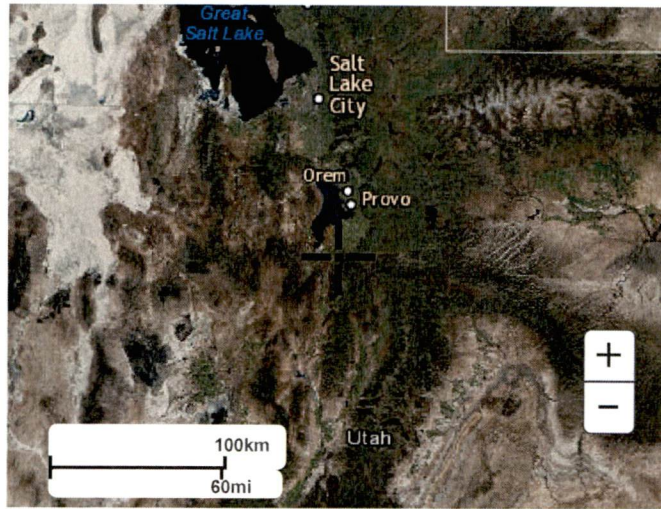

[Back to Top](#)

---

[US Department of Commerce](#)  
[National Oceanic and Atmospheric Administration](#)  
[National Weather Service](#)  
[National Water Center](#)  
1325 East West Highway  
Silver Spring, MD 20910  
Questions?: [HDSC.Questions@noaa.gov](mailto:HDSC.Questions@noaa.gov)

[Disclaimer](#)



## APPENDIX H – CURVE NUMBERS

- Curve Number Table

Curve Numbers by Land Use Data Supplied by Santaquin			Hydrologic Soil Group				Notes
Land Use ID	Land Use Description	Description - From CN resource	A	B	C	D	
A1	Agriculture	Woods (Fair) - Pasture/Grassland (Good) Combination (Table 9-1 of USDA NRCS)	38	65	74	80	
A2	Very Low Residential (>1.0 ac)	Residential Districts: 2 ac (Table 9-5 of USDA NRCS)	46	65	77	82	
A3	Service area portions of farms only	Farmstead - buildings, lanes, driveways, and surrounding lots (Table 9-1 of USDA NRCS)	76	85	89	91	
C	Commercial	Commercial and business	89	92	94	95	
CR	In APP/Out City	Commuter Rail ROW, assumed similar to RR	76	85	89	91	
ID	Paved Industrial, open gravel pits	Industrial	81	88	91	93	
MU-C	Mixed Use Commercial (Open gravel pits)	Commercial and business	89	92	94	95	
MU-R	Residential Single & In City/APP	Assumed to be equivalent to high or multi-family residential, similar to R2	77	85	90	92	
OS-N	Natural Open Space	Herbaceous: Good (Table 9-2 of USDA NRCS); Soil Type A: Pasture: Fair (Table 9-1 of USDA NRCS)	49	62	74	85	For Record: OS-N concentrates on dry or ephemeral washes
OS-P	Parks/Trail Corridor	Open Space: Fair (Table 9-5 of USDA NRCS)	49	69	79	84	
OS-W	Public Open areas (ponds)	Open Space: Fair condition; AMC III (Wet Condition)	69	84	91	93	Rounded A soil type to 69 from 68.6. For Record - Corresponds with drainages, ponds, and low wet areas.
P	Public Facilities	Open Space: Fair condition	49	69	79	84	Mainly sorted into V, V1, OS-W, C, MU-C, AND OS-N. See "Use_CodeR" for in attribute table of GIS data for modified designation.
PO	Professional Office	Commercial and business	89	92	94	95	
R1	Medium Residential (0.25-0.5 ac)	Residential Districts: 1/4 ac	61	75	83	87	
R1A	Low Residential (0.5-1.0 ac)	Residential Districts: 1/2 ac	54	70	80	85	
R2	Multi-family Residential (<0.15 ac)	Residential Districts 1/8 ac or less	77	85	90	92	
RM	Mixed-Use Residential (4-plex, mobile home)	Residential Districts 1/8 ac or less	77	85	90	92	
ROW	Streets	Streets: Paved; curbs and storm sewers	98	98	98	98	
ROW-P	Streets and gravel or vegetated sides	One very small area, gravel road data (Table 9-1 of USDA NRCS)	76	85	89	91	
RR	Railroad <del>Mixed Use Commercial (Railroad)</del>	Roads (including right-of-way): Gravel (Table 9-1 of USDA NRCS)	76	85	89	91	For Record - RR built up on gravel, natural open space and areas that pond and infiltrate during runoff around it

Yellow indicates land use types in buildout model that aren't in the existing conditions model

## APPENDIX I – HILLSIDE WATERSHED FIGURES

- East Bench Hillside Watersheds Flows and Volumes Figure
- Southwest Bench Hillside Watersheds Flows and Volumes Figure



### Legend

- City Boundary
- Debris Flows

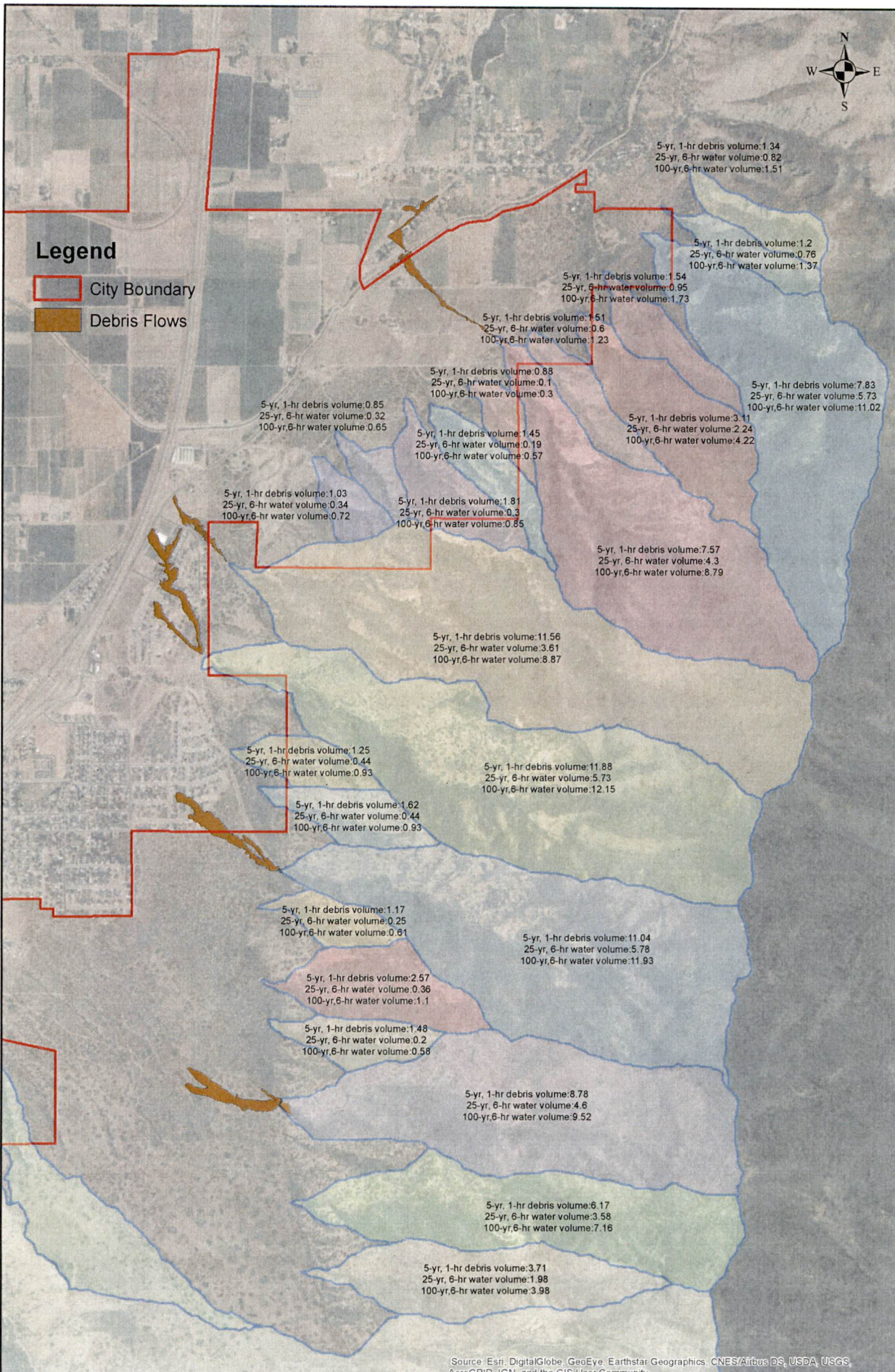

C:\Users\BPC\Documents\Projects\Hillside\HillsideBasinVolumes.mxd 7/28/2017 11:06:02 AM

Source: Esri, DigitalGlobe, GeoEye, Earthstar Geographics, CNES/Airbus DS, USDA, USGS, AeroGRID, IGN, and the GIS User Community



### Hillside Basin Volumes East Bench

DATE	7/28/2017
DRAWN	
Figure 1	

## APPENDIX J – BURNED CONDITIONS RESOURCES

### Post Burn Condition Studies & Documentation

- “Suggested Changes to AGWA to Account for Fire (V 2.1)”, USDA-ARS, 2005.
- “Predicting The Probability and Volume of Post wildfire Debris Flows in the Intermountain Western United States”, Cannon, et al, 2010.
- “Effectiveness of Debris Flow Mitigation Methods in Burned Areas”, Santi, et al, 2007.
- “Debris Basin and Deflection Berm Design for Fire-Related Debris-Flow Mitigation”, Prochaska, et al, 2008.

Suggested Changes to AGWA to Account  
for Fire (V 2.1)

H. Evan Canfield  
David C. Goodrich

USDA-ARS  
Southwest Watershed Research Center  
Tucson, Az. 85719

July, 2005

1.0 Introduction: .....	3
The AGWA (Automated Geospatial Watershed Assessment) Tool.....	3
Hydrologic Models.....	5
KINEROS2 .....	5
SWAT .....	6
2.0 Populating Parameter Values in AGWA.....	7
Table 2.1 Existing MRLC Tables .....	7
Table 2.2 Revised MRLC Table with Revised Roughness Values.....	8
3.0 Burn Severity Assessment by Burned Area Emergency Rehabilitation Teams .....	10
4.0 A Review of the Impact of Fire on Runoff Volume, Peak and Sediment Yield .....	11
5.0 Estimating Post-Fire Runoff Volume Change Using Curve Numbers .....	14
6.0 Estimating Post-Fire Peak Runoff Rates.....	18
7.0 KINEROS2 Modeling at Starmer Canyon .....	21
<i>Simulated Changes in Runoff Peak as a Result of Changes in Roughness</i> .....	23
<i>Simulated Impact of Roughness Change on Sediment Discharge at the Base of a Hillslope</i> .....	24
8.0 AGWA-SWAT Application to the 2003 Aspen Fire near Tucson, Arizona.....	27
Post-fire simulations from design or observed storms can also be spatially compared to pre-fire simulations driven with the same climate for various simulation outputs (e.g. peak runoff rate, total storm volume, total sediment transport, erosion, etc.). These differences can be displayed in percentage difference terms from the pre-fire case, or in terms of absolute differences....	29
Conclusions.....	29
9.0 Suggested Modifications to KINEROS2 to Account for Fire.....	30
Estimated Post-Fire Roughness Values .....	30
Post-Fire Ks Estimates.....	31
10. Suggested Modifications to AGWA-SWAT to Account for Fire .....	32
Modifications to AGWA SWAT .....	32
Impact of SWAT Overland Flow Calculation on Runoff Velocity.....	32
11.0 Acknowledgements.....	34
12.0 References.....	35

## 1.0 Introduction:

Wildfires can, and have had, a profound impact on the nature of watershed response to precipitation (DeBano et al. 1998). Increases in peak runoff rate and volume, as well as sediment discharge, typically increase following fires, (Robichaud, et al. 2000; Anderson et al. 1976). Mitigating these effects is one of the primary objectives of the Burned Area Emergency Response (BAER) teams. Weather and climatic conditions often force these teams to make rapid post-fire assessments for decision-making on how and where to deploy remediation measures. Building and running distributed hydrological models to predict potential impacts of fire on runoff and erosion can be a time-consuming and tedious task. The USDA-ARS Southwest Watershed Research Center, in cooperation with the U.S. EPA Office of Research and Development, and the University of Arizona have developed the AGWA geographic information system (GIS) based tool to facilitate this process. A GIS provides the framework within which spatially-distributed data are collected and used to prepare model input files and evaluate model results in a spatially explicit context.

### *The AGWA (Automated Geospatial Watershed Assessment) Tool*

AGWA provides the functionality to conduct pre- and post-fire watershed assessments for two widely used watershed hydrologic models using readily available standardized spatial datasets. The two models currently incorporated into AGWA are the Soil & Water Assessment Tool (SWAT; Arnold et al. 1994; [www.brc.tamus.edu/swat](http://www.brc.tamus.edu/swat)) and the KINematic Runoff and EROSion Model (KINEROS2; Smith et al., 1995; [www.tucson.ars.ag.gov/kineros](http://www.tucson.ars.ag.gov/kineros)). SWAT is a continuous-simulation model for use in large (river-basin scale) watersheds. KINEROS2 is an event-driven model developed for small (<100 km<sup>2</sup>) arid, semi-arid, and urban watersheds. The AGWA tool combines these models in an intuitive interface for performing multi-scale watershed assessments.

AGWA is an extension for the ArcView versions 3.X (ESRI, 2001). ArcGIS 9.0 and web versions of AGWA are currently under development. AGWA is distributed freely via the Internet as a modular, open-source suite of programs ([www.tucson.ars.ag.gov/agwa](http://www.tucson.ars.ag.gov/agwa)). Data requirements to run AGWA include elevation (USGS DEM data), land cover (EPA MLRC), soils (USDA STATSGO, USDA SURRGO, FAO) and precipitation data (observed or design storms), all of which are typically available at no cost over the Internet for the conterminous United States. A fundamental assumption of AGWA is that the user has previously gathered the necessary GIS data layers for the area of interest. All of these data layers are easily obtained for the conterminous United States. Pre-processing of the DEM to ensure hydrologic connectivity within the study area is required, and tools are provided in AGWA to aid in this task. These tasks can be done relatively rapidly within AGWA but could also be completed for forests and land areas prior to a fire. By doing so the BAER teams would only have to deal with preparing a post-fire burn-severity map for the area of interest when time is of the essence.

Once an AGWA session has been initiated, the program is designed to lead the user in a stepwise fashion through the transformation of GIS data into simulation results. A



conceptualization of the steps necessary to apply AGWA is presented in Figure 1. The AGWA Tools menu is designed to reflect the order of tasks necessary to conduct a watershed assessment. This process consists of five major steps: (1) watershed outlet identification and watershed delineation; (2) watershed subdivision by topographically controlled contributing areas; (3) model parameterization based on topography, land cover, and soils; (4) preparation of parameter and rainfall input files; and, (5) model execution and visualization, and comparison of results.

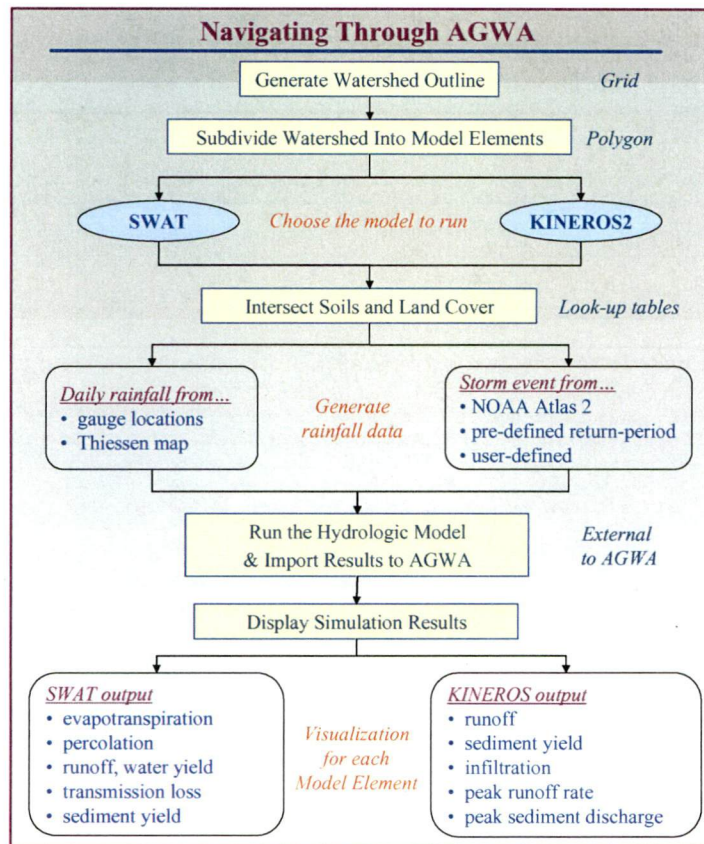

**Figure 1.1 Conceptualized and sequence of steps in the use of AGWA for hydrologic modeling**

In step (2), the geometric complexity of a watershed model representation is controlled by the user-defined contributing source area (CSA). This is the drainage area required to initiate a first-order channel and represents the transition where runoff is better treated as concentrated channel flow versus overland flow. Methods to automatically select the appropriate CSA across a broad range of basin morphologies are not clearly defined in the literature, but based on prior experience a default CSA of 2.5% of the total watershed drainage area is typically sufficient for preliminary watershed analysis. The user can modify this value, with a smaller CSA resulting in a more complex representation of the watershed (e.g. a greater number of model elements).

In regards to step (3), geometric model parameters (slope, flow length, etc.) are derived directly from the topographic data. Infiltration, interception, and erosion parameters are derived from look-up table relationships between these variables and the soil and land-

cover attribute information in the input data sets (e.g. soil texture, soil group, vegetation type). These look-up table relationships are based on the literature and limited model calibration from highly instrumented experimental watershed data. However, the user can modify them if local observations enable model calibration. A critical element in using AGWA for post-fire assessments is establishing relations that can be used to translate burn severity into changes in the infiltration, hydraulic roughness, and erosion model parameters.

After hydrologic model execution (SWAT or KINEROS2), AGWA will automatically import the model results and add them to the polygon and stream map tables for spatial, color-ramped displays (step 5). A separate module controls the visualization of model results. The user can toggle among viewing various model outputs for both upland and channel model elements, enabling the problem areas to be identified visually. If multiple land-cover scenes exist, the user can parameterize either or both of the two models and attach the results to a given watershed. Results can then be compared on either an absolute or percent change basis for each model element. Model results can also be overlaid with other digital data layers to further prioritize management activities. Examples of AGWA applications for assessments of the hydrologic impacts of past land-cover change, as well as of alternative futures land-use change, can be found in Hernandez et al. (2000), Miller et al. (2002), and Kepner et al. (2004).

#### Hydrologic Models

Key components of AGWA are the hydrologic models used to evaluate the effects of land cover and land use on watershed response. Both the KINEROS2 and SWAT models are able to process complex watershed representations to explicitly account for spatial variability of soils, rainfall distribution patterns, and vegetation.

#### KINEROS2

KINEROS2 is an event-oriented, physically based model describing the processes of interception, infiltration, surface runoff, and erosion from small agricultural and urban watersheds, and is based on Hortonian overland flow theory (Smith et al., 1995). In this model, watersheds are represented by discretizing contributing areas into a cascade of one-dimensional overland flow and channel elements using topographic information. Surface flow in both overland and channel elements is modeled using a finite difference approximation of the one-dimensional kinematic wave equations in which upslope supply, rainfall rates, and infiltration rates are considered simultaneously at each finite difference node. The infiltration component is based on the simplification of the Richard's equation posed by Smith and Parlange (1978). It is relatively well suited to describing the hydrodynamics of runoff and erosion processes on burned southwestern watersheds, where infiltration rates are low, and rainfall is infrequent but intense. Sediment transport is treated using unsteady, one-dimensional convective-transport equations similar to those used for runoff. Entrainment of sediment is modeled as resulting from raindrop impact or flow-induced entrainment. Sediment transport for up

to five, non-interacting particle sizes is described using the Engelund and Hansen (1967) total load equation.

### SWAT

SWAT is a river basin scale model developed to predict the impact of land-management practices on water, sediment, and agricultural chemical yields for large, complex watersheds with varying soils, land use, and management conditions over long periods of time (Arnold et al. 1994). The model combines empirical and physically-based equations, uses readily available inputs, and enables users to study long-term impacts. The hydrology model is based on the water balance equation:

$$SW_t = SW + \sum_{i=1}^t (R_i - Q_i - ET_i - P_i - QR_i) \quad (1)$$

where  $SW$  is the soil water content minus the 15-bar water content,  $t$  is the time in days, and  $R$ ,  $Q$ ,  $ET$ ,  $P$ , and  $QR$  are the daily amounts of precipitation, runoff, evapotranspiration, percolation, and return flow, respectively; all the units are in millimeters. Since the model maintains a continuous water balance, complex basins are subdivided to reflect differences in ET for various crops, soils, etc. Thus, runoff is predicted separately for each sub area and routed to obtain the total runoff for the basin.

## 2.0 Populating Parameter Values in AGWA

The basis of the modifications to assume that the majority of the changes in burned situations occur on the hillslopes rather than the channels. The means by which runoff and peak are implemented in SWAT and KINEROS in AGWA are the cover tables associated with the different cover mapping systems. The table for the MRLC classification is as follows:

**Table 2.1 Existing MRLC Tables**

Class Name	A	B	C	D	Cover	Int	n
11 Open Water	100	100	100	100	0	0.00	0.000
12 Perrenial Ice/Snow	98	98	98	98	0	0.00	0.000
21 Low Intensity Residential	77	85	90	92	15	0.10	0.150
High Intensity							
22 Residential	81	88	91	93	10	0.08	0.120
Commercial/Industrial/							
23 Transportation	89	92	94	95	2	0.05	0.010
31 Bare Rock/Sand/Clay	96	96	96	96	2	0.00	0.010
Quarries/Strip							
32 Mines/Gravel Pits	78	85	90	92	2	0.00	0.010
33 Transitional	72	82	87	90	20	0.00	0.010
41 Deciduous Forest	55	55	75	80	50	1.15	0.015
42 Evergreen Forest	55	55	70	77	50	1.15	0.015
43 Mixed Forest	55	55	75	80	50	1.15	0.015
51 Shrubland	63	77	85	88	25	3.00	0.055
61 Orchards/Vinyards/Other	77	77	84	88	70	2.80	0.040
71 Grasslands/Herbaceous	49	69	79	84	25	2.00	0.015
81 Pasture/Hay	68	79	86	89	70	2.80	0.040
82 Row Crops	72	81	88	91	50	0.76	0.040
83 Small Grains	65	76	84	88	90	4.00	0.040
84 Fallow	76	85	90	93	30	0.50	0.040
Urban/Recreational							
85 Grasses	68	79	86	89	90	2.50	0.040
91 Woody Wetlands	85	85	90	92	70	1.15	0.060
Emergent Herbaceous							
92 Wetlands	77	77	84	90	70	1.15	0.060

In reviewing this table, it is clear that the CN estimates are basically from the TR55 manual. However, the manning roughness values are excessively small. In order to prepare a tool that can do change analysis, more reasonable roughness values must be substituted on the table for the unburned condition. A revised estimate of baseline roughness values can be derived from the KINEROS documentation, TR-55 and other studies. While categories in the KINEROS documentation and TR-55 may not fit exactly with the categories on this table, the values are a reasonable approximation for the tables in the category. For the riparian classifications, I found no estimates of roughness, so these have been approximated.

**Table 2.2 Revised MRLC Table with Revised Roughness Values**

Class Name	A	B	C	D	Cover	Int	n
11 Open Water	100	100	100	100	0	0.00	0.000
12 Perrenial Ice/Snow	98	98	98	98	0	0.00	0.000
21 Low Intensity Residential	77	85	90	92	15	0.10	0.150
High Intensity Residential							
22 Residential Commercial/Industrial/	81	88	91	93	10	0.08	0.120
23 Transportation	89	92	94	95	2	0.05	0.011*
31 Bare Rock/Sand/Clay Quarries/Strip	96	96	96	96	2	0.00	0.011*
32 Mines/Gravel Pits	78	85	90	92	2	0.00	0.010
33 Transitional	72	82	87	90	20	0.00	0.010
41 Deciduous Forest	55	55	75	80	50	1.15	0.4#
42 Evergreen Forest	55	55	70	77	50	1.15	0.8#
43 Mixed Forest	55	55	75	80	50	1.15	0.6#
51 Shrubland	63	77	85	88	25	3.00	0.055
61 Orchards/Vinyards/Other	77	77	84	88	70	2.80	0.040
71 Grasslands/Herbaceous	49	69	79	84	25	2.00	0.13*
81 Pasture/Hay	68	79	86	89	70	2.80	0.40*
82 Row Crops	72	81	88	91	50	0.76	0.17#
83 Small Grains	65	76	84	88	90	4.00	0.17#
84 Fallow Urban/Recreational	76	85	90	93	30	0.50	0.05*
85 Grasses	68	79	86	89	90	2.50	0.41*
91 Woody Wetlands Emergent Herbaceous	85	85	90	92	70	1.15	0.60@
92 Wetlands	77	77	84	90	70	1.15	0.60@

@ - estimated based on covers with similar CN and cover values

# - From TR 55

\* - From KINEROS web site

In order to apply KINEROS2, the values for parameters for infiltration and soil erodibility as a function of rainsplash and sediment transport capacity need to be entered into the model. Table 1.3 shows a subset of the parameter values used to populate the parameters in KINEROS2 as a function of texture.

<b>TEXTURE</b>	<b>KS</b>	<b>G</b>	<b>POR</b>	<b>SMAX</b>	<b>CV</b>	<b>SAND</b>	<b>SILT</b>	<b>CLAY</b>	<b>DIST</b>	<b>KFF</b>
<b>CL</b>	2.300	259.000	0.464	0.840	0.940	32.000	34.000	34.000	0.240	0.390
<b>S</b>	210.000	46.000	0.437	0.950	0.690	91.000	1.000	8.000	0.690	0.180
<b>SC</b>	1.200	302.000	0.430	0.750	1.000	50.000	4.000	46.000	0.340	0.360
<b>SCL</b>	4.300	263.000	0.398	0.830	0.600	59.000	11.000	30.000	0.400	0.360
<b>SI</b>	3.000	260.000	0.450	0.920	0.550	8.000	81.000	11.000	0.130	0.430
<b>SIC</b>	0.900	375.000	0.479	0.880	0.920	9.000	45.000	46.000	0.150	0.310
<b>SICL</b>	1.500	345.000	0.471	0.920	0.480	12.000	54.000	34.000	0.180	0.400
<b>SIL</b>	6.800	203.000	0.501	0.970	0.500	23.000	61.000	16.000	0.230	0.490
<b>SL</b>	26.000	127.000	0.453	0.910	1.900	65.000	23.000	12.000	0.380	0.320

### 3.0 Burn Severity Assessment by Burned Area Emergency Rehabilitation Teams

BAER Team Assessments and burn severity classifications. Review of burn severity maps and potential burn severities under different cover types. In general, the following characterization describes burn severity:

High –Ground cover is almost completely consumed; the ash layer may be up to two inches deep; tree crowns are completely consumed; few to no leaves or needles remain on trees; tree mortality may be close to 100 percent.

Moderate –Shrub canopy may be all or partly consumed; shrubs skeletons and root crowns may remain; some identifiable char and litter are beneath a thin ash layer; soil structure is intact; fine and very fine roots remain; scorched brown needles or leaves remain on trees; tree mortality is 40-80 percent.

Low –Vegetation is lightly scorched; large trees are mostly alive; very small fuels have been consumed.

A more quantitative summary is presented in table 3.1.

	----- Burn severity -----		
Soil and litter parameter	Low	Moderate	High
Litter	Scorched, charred, consumed	Consumed	Consumed
Duff	Intact, surface char	Deep char, consumed	Consumed
Woody debris - small	Partly consumed, charred	Consumed	Consumed
Woody debris - logs	Charred	Charred	Consumed, deeply charred
Ash color	Black	Light colored	Reddish, orange
Mineral soil	Not changed	Not changed	Altered structure, porosity, etc
Soil temp. at 0.4 inch (1 cm)	<120 °F (<50 °C)	210-390 °F (100-200 °C)	>480 °F (>250 °C)
Soil organism lethal temp.	To 0.4 inch (1 cm)	To 2 inches (5 cm)	To 6 inches (16 cm)

Burn severity classification based on postfire appearances of litter and soil and soil temperature profiles (Hungerford 1996; DeBano and others 1998).

#### 4.0 A Review of the Impact of Fire on Runoff Volume, Peak and Sediment Yield

Following wildfire, runoff peak and volume have been observed to increase over pre-fire conditions (e.g. Robichaud, et al. 2000). Likewise, sediment discharge and sedimentation rates have been observed to increase. Therefore, runoff in post-fire conditions has the potential for downstream flooding and sedimentation that can degrade reservoirs used for drinking water supplies. For these reasons, the Burned Area Emergency Response (BAER) teams primarily address rehabilitation efforts to reduce runoff and erosion.

Some of the physical changes following fire that have been identified to contribute to changes in hydrologic response include (DeBano et al. 1998):

- removal of canopy cover, which decreases interception of rainfall and increases the portion of the rainfall that hits the ground, and eliminates the buffering effect of canopy on rainfall intensity, which is an important effect in the desert southwest subject to convective rainstorms,
- collapse of soil structure and consequent reduction of soil porosity,
- creation of hydrophobic soils which can reduce infiltration rates,
- creation of ash residues that can clog pores, thus resulting in decreased infiltration rates,
- removal of ground cover, which exposes soil, allowing sediment to be entrained by raindrop impact, reduces roughness and allows runoff to move more rapidly downslope, which reduces the time water is ponded on the hillslope and allowed to infiltrate, and produces higher runoff rates and flows with higher sediment concentration and transport capacity.

Observations show that these physical changes cause a major change in observed runoff volume, peak and sediment yield in the southwestern United States. Robichaud et al. (2000) summarized the available data on changes in runoff and erosion following fire. The increase in annual water yield following fire in southwestern conifer forests has been observed to be a factor of two or less. In contrast, southwestern conifer watersheds have been shown to experience a five to 100 fold increase in post-fire runoff peak flows (Anderson et al. 1976). Pre-fire sediment-yield on burned conifer forest watersheds in the southwest is almost too small to measure (0.0003 t/ha: DeBano et al. 1996). However, post-fire sediment-yield on these watersheds has been measured to be some of the highest ever measured at 370 t/ha (Hendricks and Johnson, 1944), though it has also been observed to be only 1.6 t/ha in one study on a high severity burn (DeBano et al. 1996). These large differences indicate that post-fire erosion rates are highly variable, but can be extremely high.

Using rainfall and runoff depths for summer monsoon events that occurred on Marshall Gulch during the 1950s and after the fire in 2003 and 2004, Curve Number (CN) values were calculated (Hawkins, 1993). Curve numbers are plotted against rainfall in Figure 4.1.



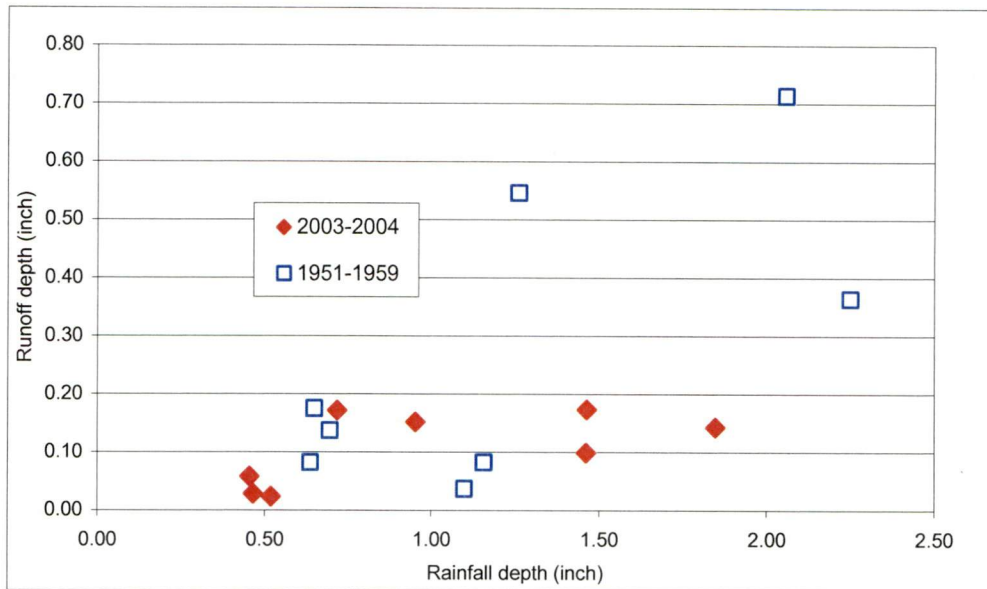

**Figure 4.1 – Rainfall Plotted Against Runoff for Events from Before and After the Aspen Fire**

Using these data, it is possible to calculate Curve Numbers for before and after the fire as shown in Figure 4.2:

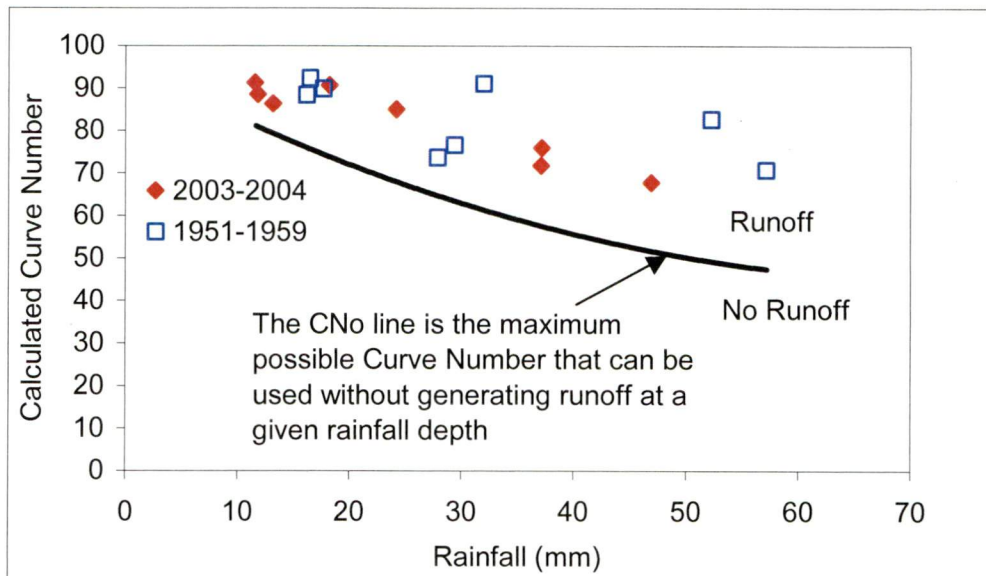

**Figure 4.2 – Curve Number Plotted Against Rainfall Depth**

Evaluation of this figure shows that there is no apparent increase in CN in post-fire conditions, and therefore no obvious change in runoff volume production in post-fire conditions. The lack of clear differences between the CNs in burned and unburned situations can be attributed to errors in rainfall and runoff measurement, as well as the comparison of data sets separated in time by forty years. However, the trends support the findings of Springer and Hawkins (this volume), which show small change in post-fire

Curve Numbers at Starmer Canyon, and increasingly declining CNs with rainfall, indicative of the 'complacent' watershed response (Hawkins, 1993). Such 'complacent' behavior indicates that a single CN may be inappropriate for estimating runoff volume in forested conditions either before or after the fire.

Surface runoff in SWAT is estimated with a modification of the SCS Curve Number method (U. S. Department of Agriculture, 1986). A survey of Burned Area Emergency Response (BAER) plans showed that the Curve Number (CN) approach is often used in post-fire assessment. Currently, many BAER teams select post-fire CNs based on experience, without the value of careful post-fire data analysis. Two papers in this volume calculated post-fire CNs and found a small change in post-fire runoff volume (Canfield et al; Springer and Hawkins). However, Canfield et al. (2005) found that change in post-fire peak was approximately an order of magnitude higher after the Aspen Fire in Pima County, AZ, even though there was no significant change in post-fire CN (i.e. little change in total post-fire runoff volume). McLin et al. (2001) also noted that post-fire runoff peaks can be very high, while runoff volumes are less changed. Therefore users of unit hydrographs have chosen to overestimate volume in order to accurately predict peak runoff rates.

## 5.0 Estimating Post-Fire Runoff Volume Change Using Curve Numbers

Surface runoff in SWAT is estimated with a modification of the SCS Curve Number method (U. S. Department of Agriculture, 1986). A survey of Burned Area Emergency Response (BAER) plans showed that the Curve Number (CN) approach is often used in post-fire assessment. Currently, many BAER teams select post-fire CNs based on experience, without the value of careful post-fire data analysis. Two papers in this volume calculated post-fire CNs and found a small change in post-fire runoff volume (Canfield et al; Springer and Hawkins). However, Canfield et al. (2005) found that change in post-fire peak was approximately an order of magnitude higher after the Aspen Fire in Pima County, AZ, even though there was no significant change in post-fire CN (i.e. little change in total post-fire runoff volume). McLin et al. (2001) also noted that post-fire runoff peaks can be very high, while runoff volumes are less changed. Therefore users of unit hydrographs have chosen to overestimate volume in order to accurately predict peak runoff rates.

Analysis of post-fire CNs from BAER team reports for several burn severities on fires in the Southwest (Hayman, CO; Cerro Grande, NM; and, Oracle Hill, AZ) and modeled runoff from a fifty mm storm indicate up to two orders of magnitude change in runoff volume, which is inconsistent with observations. To select a CN that more accurately reflects the calculated post-fire CNs described in other studies in this volume, (Canfield et al; Springer and Hawkins), we employed a relationship between CN and cover.

The National Land Cover Dataset (NLCD) includes an estimate of percent cover for each land-cover type. CNs for each of these have been estimated based on Hydrologic Soils Group classes A, B, C, and D, and cover conditions (USDA, 1986). For natural land covers (excluding wetlands and most agricultural classes areas), and urbanized areas, relatively strong relationships exist between percent cover and CN (Figure 5.1). If we employ these regression relationships, a revised post-fire CN can be estimated using a post-fire estimate of cover for each hydrologic soil group. By assuming a 15% reduction

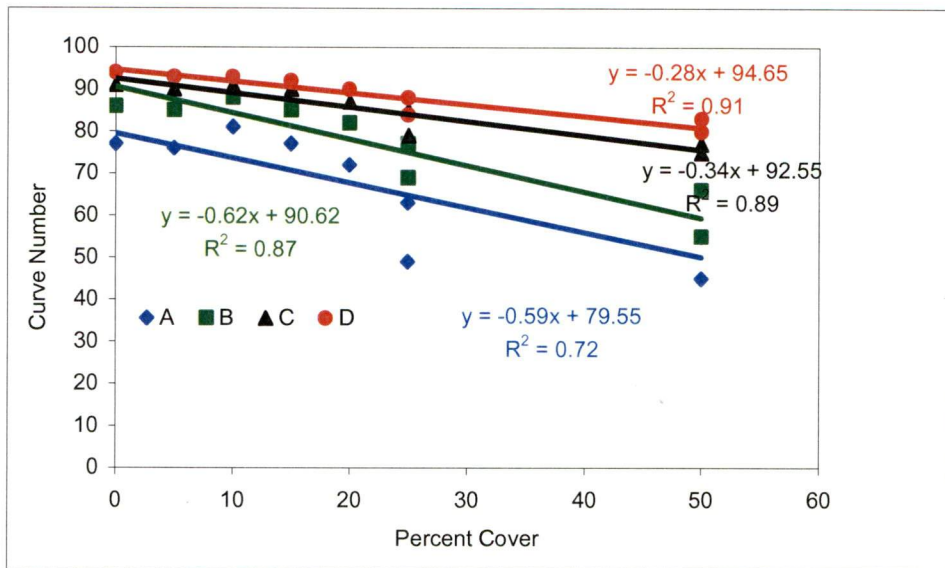

**Figure 5.1 – Relationship Between Cover and Curve Number for Each Hydrologic Soils Group**

in cover for low-severity burns, a 50% reduction for high-severity burns (as is assumed in Disturbed WEPP - <http://forest.moscowfsl.wsu.edu/cgi-bin/fswpep/wd/weppdist.pl>, and a 32% reduction for moderate-severity burns, we can obtain revised estimates of post-fire CNs (Table 5.1).

**Table 5.1: Original and revised AGWA-based Curve Number estimates as a function of hydrologic soil group, land-cover class and burn severity (low, moderate or high)**

Class	Name	Cover	A	B	C	D
84a	Bare	0	77	86	91	94
84	Fallow	5	76	85	90	93
22	High Intensity Residential	10	81	88	91	93
21	Low Intensity Residential	15	77	85	90	92
33	Transitional	20	72	82	87	90
51	Shrubland	25	63	77	85	88
71	Grasslands/Herbaceous	25	49	69	79	84
41	Deciduous Forest	50	55	55	75	80
42	Evergreen Forest	50	45	66	77	83
43	Mixed Forest	50	55	55	75	80
51	Shrubland	25	63	77	85	88
411	Deciduous Forest	43	59	60	78	82
421	Evergreen Forest	43	49	71	80	85
431	Mixed Forest	43	59	60	78	82

51l	Shrubland	21	65	79	86	89
41m	Deciduous Forest	34	65	65	80	85
42m	Evergreen Forest	34	55	76	82	88
43m	Mixed Forest	34	65	65	80	85
51m	Shrubland	17	68	82	88	90
41h	Deciduous Forest	25	70	71	83	87
42h	Evergreen Forest	25	60	82	85	90
43h	Mixed Forest	25	70	71	83	87
51h	Shrubland	12	73	88	91	91

Note: l - low severity burn  
 m - moderate severity burn  
 h - high severity burn

Several trends in the Table 5.1 AGWA-derived CNs can be noted in comparison to BAER team estimates (not shown). The estimated CNs in Table 5.1 are generally higher for unburned conditions and lower for burned conditions than estimates used by BAER teams. This results in higher runoff depths for pre-fire conditions and lower runoff depths for post-fire conditions. To illustrate these differences, runoff depth has been estimated using the CNs in Table 5.1, and using CNs from BAER team reports on the Cerro Grande (Evergreen), and Oracle Hill Fires (Deciduous Forest and Shrubland) using a 40-mm rainfall event.

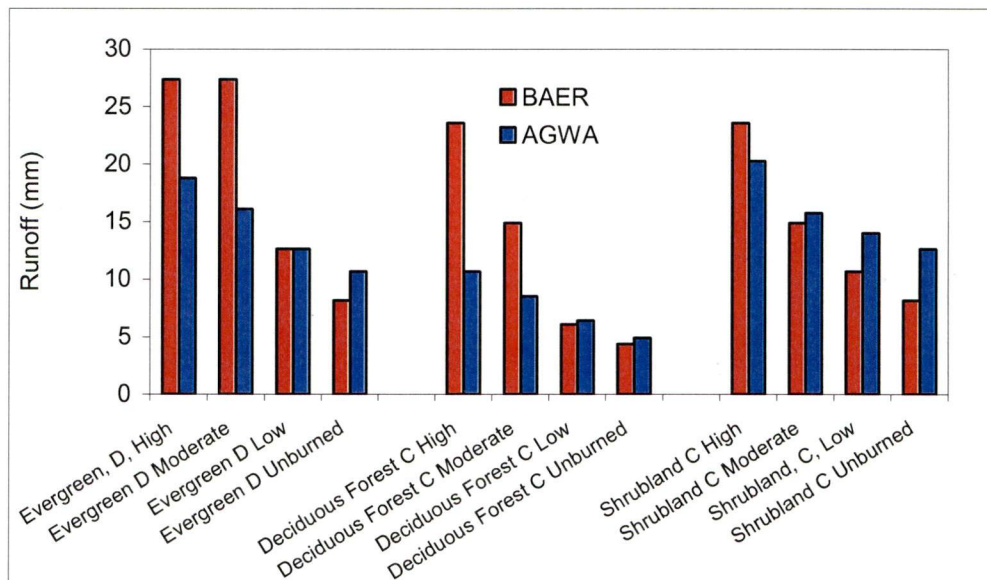

**Figure 5.2 – Calculated Runoff from a 40 mm storm using AGWA and BAER team estimates (cover, hydrologic soil group, burn severity)**

The values in Figure 5.2 show that the AGWA estimates tend to produce a higher runoff volume for unburned conditions and a lower runoff volume for burned conditions. This results in a smaller estimate of runoff-volume change as a result of wildfire. This is

consistent with the results described in the Curve Number estimates for Marshall Gulch described in chapter 8, and Springer and Hawkins (2005), which show that observed post-fire runoff-volume change is small relative to the large change in runoff peak rates. Note that the 40-mm storm event is quite large; and the differences demonstrated in Figure 5.2 would be greater for smaller events because a higher fraction of the rainfall will go to the initial abstraction. .

## 6.0 Estimating Post-Fire Peak Runoff Rates

Data are available from a burned conifer watershed at the Marshall Gulch station which drains 830 ha in Pima County, AZ burned by the Aspen Fire in June 2003. Historical data exist for the Marshall Gulch site from 1951 to 1959. Following the fire, the gauge was reestablished. Because rainfall and runoff data are rarely available from burned watersheds for before and after a fire, the Marshall Gulch data offers an opportunity to examine changes in runoff peak and volume following fire. Currently, rainfall data is recorded at three different gauging stations on or near the watershed.

However, during the 1950s, rainfall was collected at only one location on the watershed. The burn upstream of the Marshall Gulch station was spotty. Most of the watershed was burned, but high, moderate and low severity burns were observed (see chapter 8). Soils on the watershed are sandy loam developed in weathered granite bedrock. In the pre-fire condition, runoff could occur days after an event as illustrated by Figure 6.1.

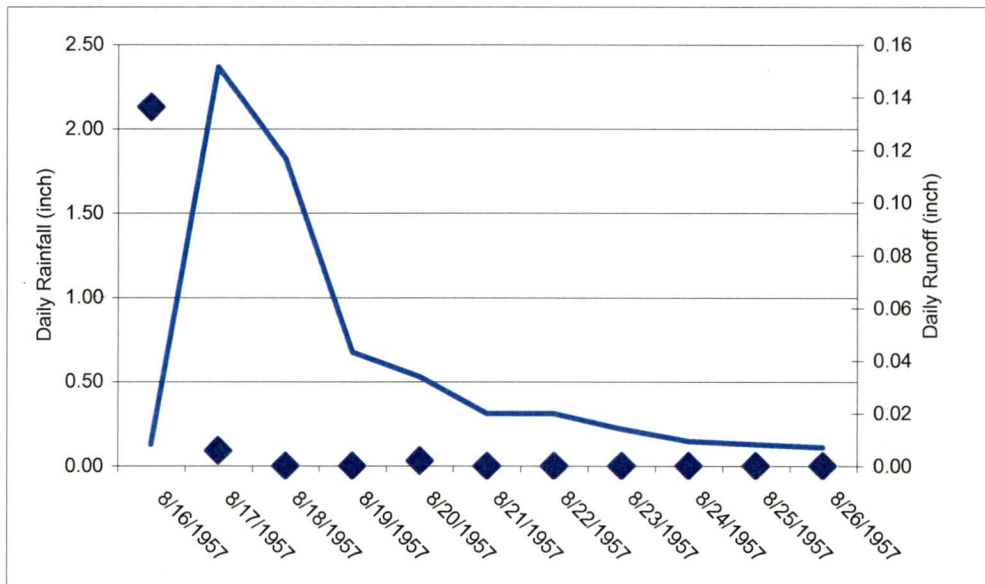

**Figure 6.1- Rainfall (left axis) and Runoff (right axis) vs Time (days)**

In contrast, in post-fire conditions, event duration was much shorter as indicated for the July 23, 2003 event in Figure 6.2.

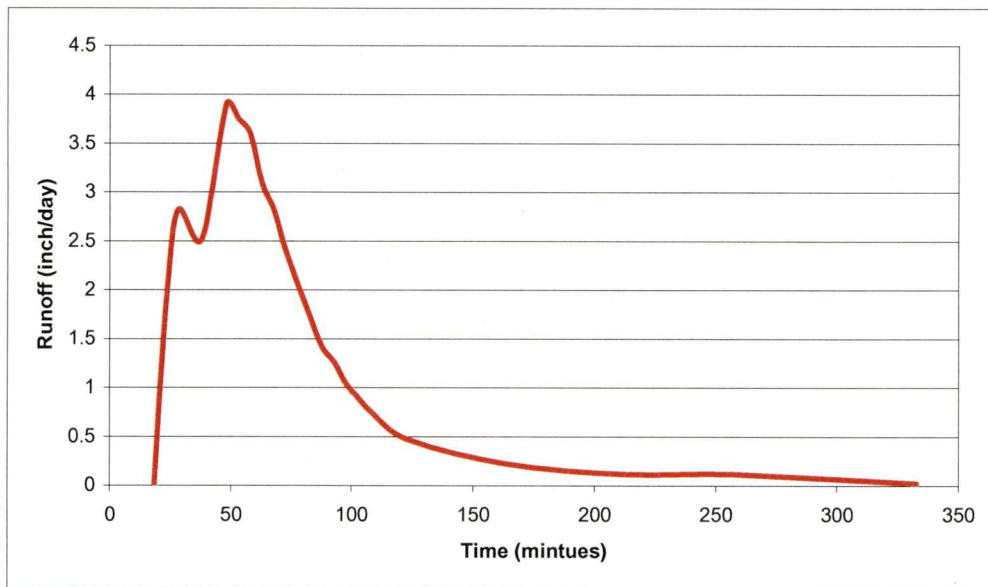

**Figure 6.2 - Runoff (right axis) vs Time (minutes)**

The fact that the event durations were so long under pre-fire conditions and so short under post-fire conditions illustrates that the most profound impact of fire is to reduce runoff travel times and increase peak. While the volume and CN estimates suggest little change in runoff following the fire at Marshall Gulch, a clear change can be observed in the hydrograph peaks and hydrograph base time. Review of the data show that following a rainfall event in the 1950s, a runoff event could continue for several days. However, following the fire, the time of base often was no longer than a few hours. Hawkins (2004 pers. comm.) has suggested plotting  $Q_{peak}$  vs  $Q_{avg}$ . Using this method a clear change can be seen as shown in Figure 6.3.

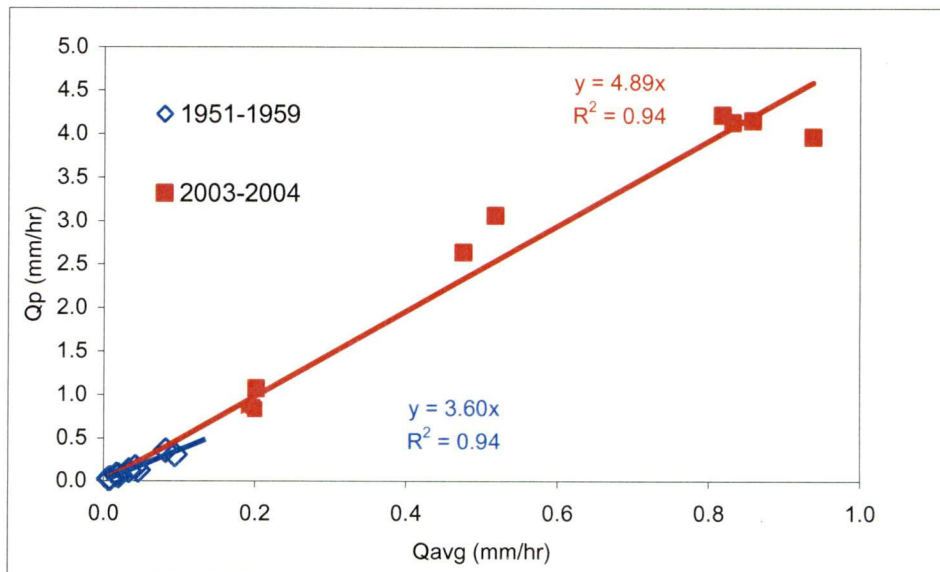

**Figure 6.3 – Peak Discharge plotted against Average Discharge for Before and After the Marshall Gulch Fire**



Post-fire peaks are clearly much greater than pre-fire peaks. Furthermore, while a strong correlation of the form  $Q_p = \text{coefficient} * Q_{avg}$  exists for both datasets, the coefficients are different, which suggests the hydrograph generation mechanisms may have changed producing a hydrograph of a different shape.

Evaluation of the peak and volume data from Marshall Gulch shows a relatively large change in peak runoff and relatively little change in runoff volume. This finding is consistent with the observations of Anderson et al. (1976) and Robichaud et al. (2000). Therefore, analysis of this data set suggests that post-fire prediction tools must be modified to produce much higher post-fire runoff peaks, without a commensurate increase in predicted runoff volume.

What is clear from evaluation of the peak and volume data is that the most profound impact in runoff is in peak runoff rather than runoff volume, which has been seen before. Other studies of changes in post-fire hydrology have shown increases in runoff volume (e.g. see Robichaud et al 2000 table 3). Therefore, it would not be appropriate to conclude that there is never a change in volume, but rather that the most profound impact of fire is to increase runoff peaks, which this data set clearly illustrates.

## 7.0 KINEROS2 Modeling at Starmer Canyon

The available rainfall and runoff data were used to select optimal model parameter estimates for the KINEROS2 model at Starmer Canyon. The optimized model fit is summarized in Table 1. While data are available for more events, only hydrographs that could be modeled well (as determined by a Nash-Sutcliffe statistic greater than 0.7) using KINEROS2 were used in this analysis. The fact that some events could not be modeled well may be attributed to errors in rainfall and runoff measurement.

**Table 7.1 – Optimal Parameter Values for Selected Events at Starmer Canyon**

Event	Rainfall Depth (mm)	Days Since Fire	Ks (mm/hr)	n Channel	n Hillslope	Nash-Sutcliffe
6/28/2000	11.3	37	3.361	0.193	0.014	0.89
7/9/2000	14.3	48	0.390	0.013	0.213	0.74
10/22/2000a	14.1	154	1.183	0.151	0.430	0.85
10/22/2000b	12.3	154	0.866	0.150	0.087	0.85
8/9/2001	9.8	444	2.172	0.008	0.716	0.88
7/14/2002	9.8	783	3.312	0.041	1.175	0.95
8/11/2003	22.6	1176	7.540	0.117	1.053	0.90

The poorest fit hydrograph (7/9/00) used in this simulation is shown in Figure 7.1.

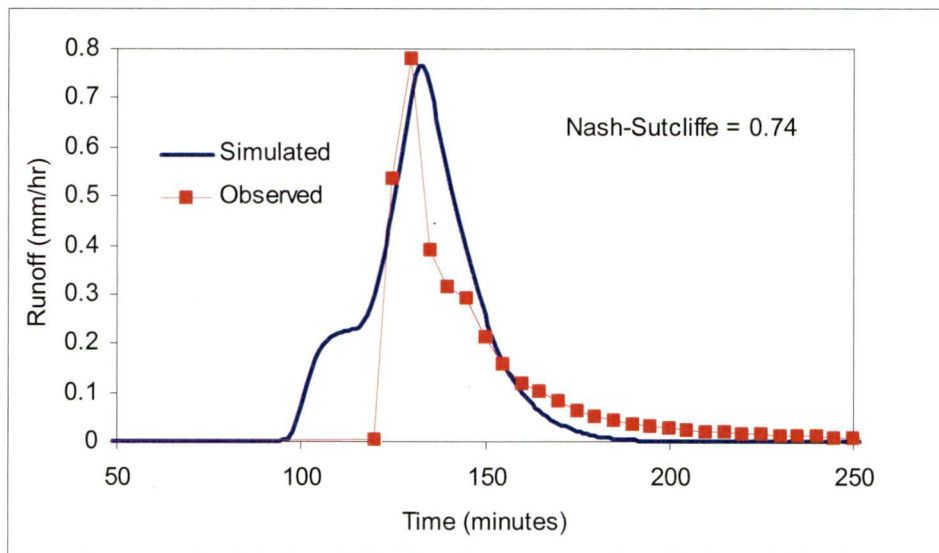

**Figure 7.1 – Comparison of Observed and Simulated Hydrograph for the Poorest fit Hydrograph Used in the Analysis at Starmer Canyon**

Using these data, an interesting trend is observed in optimal hillslope roughness (Figure 7.2). For the first event, the optimal hillslope roughness was 0.014, which is very close to the value of 0.011 recommended for bare soil by Engman (1986). For the last event the optimal hillslope roughness value is 1.05, which does not differ greatly from the value of 0.8 for wooded conditions recommended by Engman.

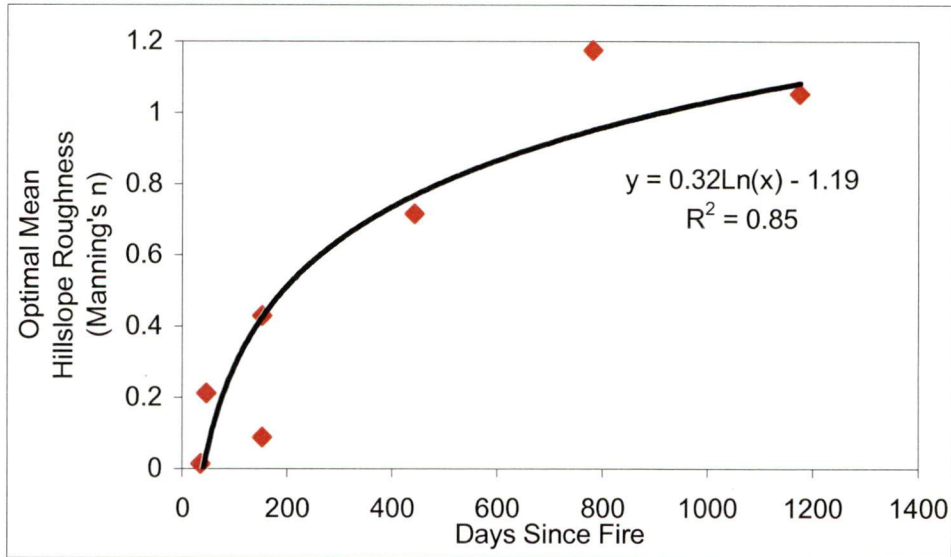

**Figure 7.2 – Optimal Hillslope Roughness for Events that Occurred after the Cerro Grande Fire at Starmer Canyon Plotted vs Time**

The trend of increasing hillslope roughness over time is to be expected because vegetation will begin to grow. In addition, soil compaction will be reduced by the development of a root system and processes such as freeze-thaw, which can further increase the porosity in the soil.

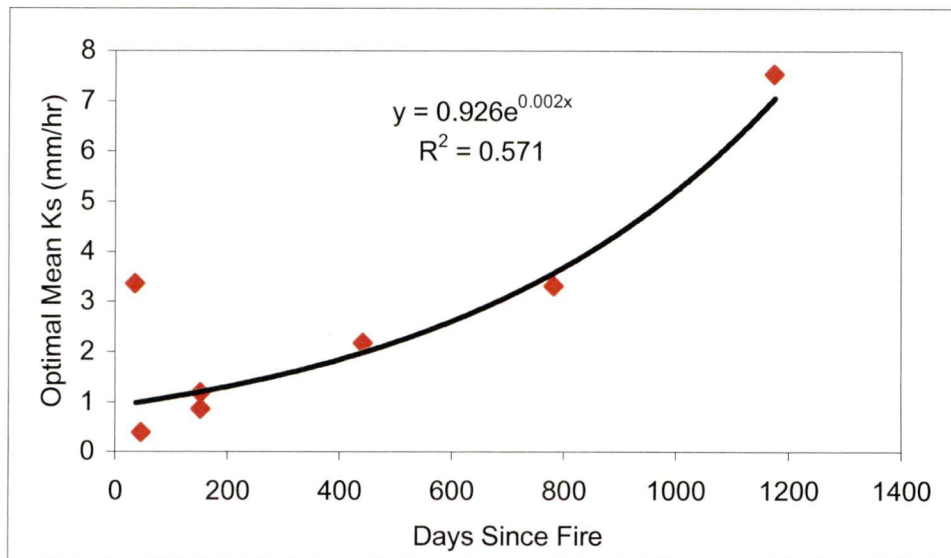
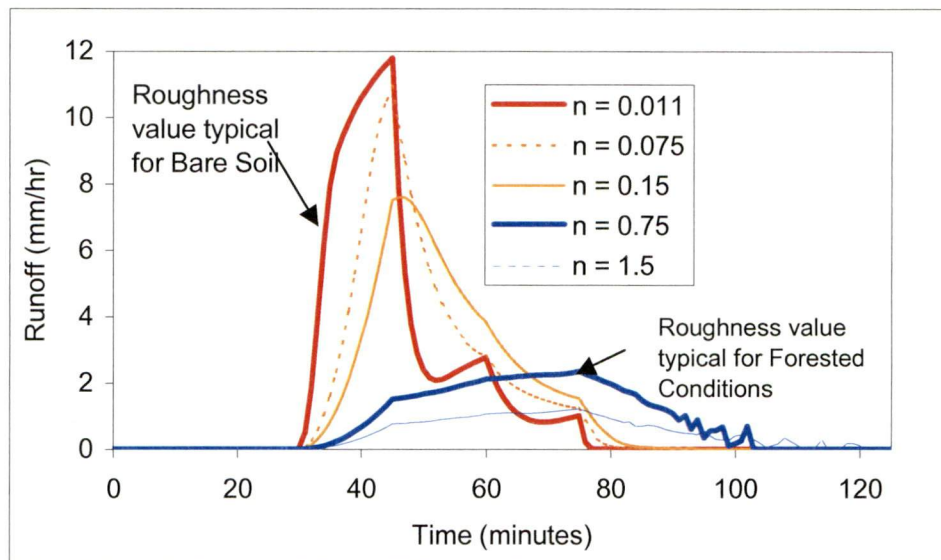

**Figure 7.3 – Optimal Hillslope Hydraulic Conductivity Following the Cerro Grande Fire at Starmer Canyon Plotted vs. Time**

The effects of these changes can also be observed in the changes in the optimal saturated hydraulic conductivity ( $K_s$ ) over time as shown in Figure 7.3.

#### *Simulated Changes in Runoff Peak as a Result of Changes in Roughness*

Of the three parameters optimized, the modeled peak runoff predictions are most sensitive to hillslope roughness. Figure 7.4 shows how changes in hillslope roughness can impact runoff peak for a 95 m long hillslope in Starmer Canyon subject to an 11 mm rainfall event with a peak 15-minute intensity of 19.7 mm/hr. In this case, a change from bare to forested roughness results in a six-fold change in runoff peak and a three-fold change in runoff volume.



**Figure 7.4 – Hillslope Runoff Plotted vs time for Different Hillslope Roughness Values**

Runoff on bare soil is often assumed to produce Hortonian overland flow, which is the runoff mechanism described in KINEROS2. While Engman (1986) has determined a roughness value for forested conditions that can be used to estimate hillslope roughness under Hortonian conditions, runoff in forested watersheds is generally thought to be dominated by subsurface storm flow and return flow (Dunne and Leopold, 1978), conditions not simulated in KINEROS2. Furthermore, with highest roughness rates ( $n=0.75$  and  $1.5$ ) the Hortonian processes simulated in KINEROS2 may produce instability on the recession limb of the hydrograph at low flow rates (Figure 7.5). Therefore, while KINEROS2 may provide a reasonable description of runoff for post-fire conditions, it does not simulate the processes generally assumed to produce runoff in pre-fire conditions or in fully recovered forested watersheds. These model deficiencies will be addressed in future versions of KINEROS2.

By necessity, most simulation models are unable to simulate all processes inherent in watershed rainfall-runoff response. However, they can provide useful approximations. While KINEROS2 does not describe the runoff producing processes in forested

conditions, the erosion from Hortonian overland flow simulated by KINEROS2 should be greater than the erosion generated by subsurface storm flow and return flow. Therefore, it can be considered to be a conservatively high value.

*Simulated Impact of Roughness Change on Sediment Discharge at the Base of a Hillslope*

Using erosion parameters selected by AGWA for KINEROS2 based on USDA soil classification and empirical relationships developed from the USLE soil erodibility factor (Woolhiser et al, 1990), the impact of hillslope roughness on erosion can be illustrated in Figure 7.5.

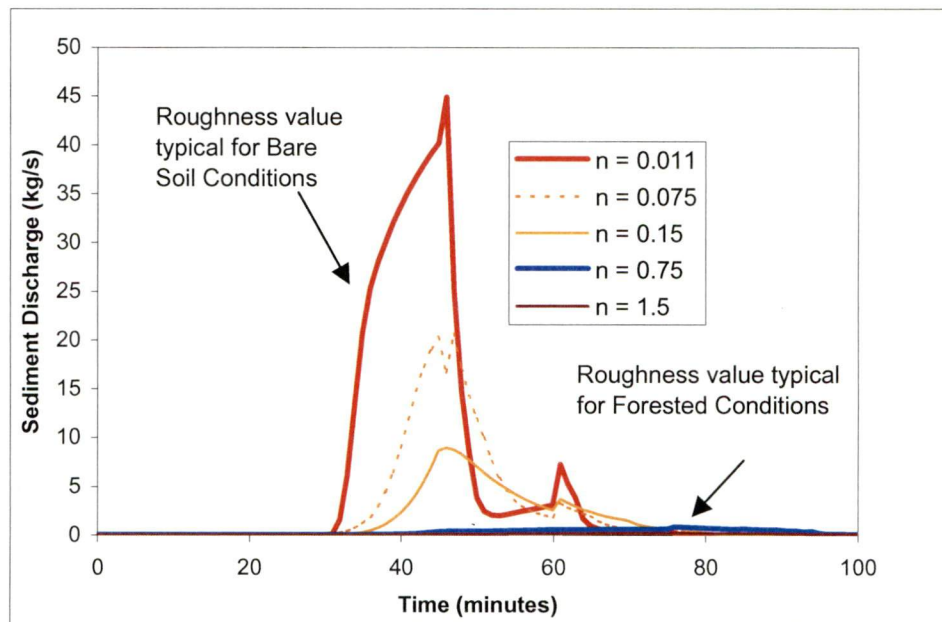

**Figure 7.5 – Hillslope Sediment Discharge Plotted vs Time for Different Hillslope Roughness Values**

Since erosion parameters are unchanged in these simulations, and sediment entrainment by raindrop impact should be relatively unchanged, the simulated change in sediment discharge rates can be attributed to the change in sediment transport associated with the increased flow rates that occur on hillslopes with lower roughness.

Comparison of the hillslope runoff and hillslope sediment delivery show that hillslope roughness has a relatively greater increase in sediment delivery as indicated in Figure 7.6. This example shows a two-fold decrease in runoff volume from bare to wooded conditions. As mentioned previously, there was a six-fold change in peak runoff rate from bare to wooded conditions. However, the factor of twenty decrease in sediment delivered from the hillslope to the channel indicates that for this simulation, sediment is more sensitive to this change in roughness than either runoff peak or runoff volume. Furthermore, the unburned estimates are likely to be high because KINEROS2 describes Hortonian overland flow for unburned conditions when subsurface storm flow and return flow are likely to be more appropriate. Therefore, the relative change estimate may be low.

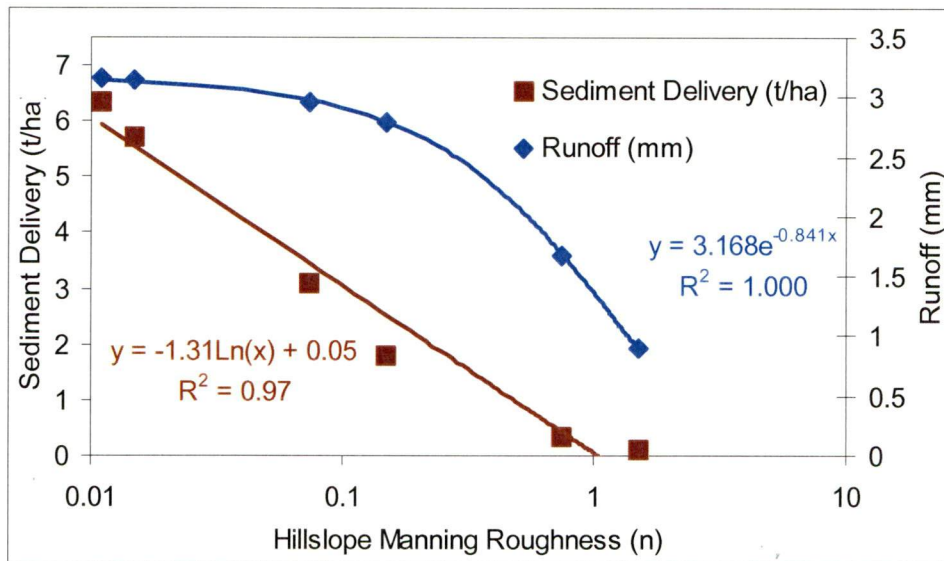

**Figure 7.6 – Hillslope Sediment Delivery and Runoff Volume Plotted vs hillslope roughness values**

## Conclusions

This study shows that peak runoff rates in post-fire conditions can be several hundred percent greater than pre-fire conditions, and that modeled peak discharge and sediment delivery are strongly dependent on hillslope roughness. Optimal parameter sets for a series of events at the Starmer Canyon watershed suggest an increase in hillslope roughness from bare conditions after the fire to hillslope roughness similar to wooded conditions three years later, which is consistent with watershed recovery. The fact that these roughness values are consistent with independent estimates for these values for these conditions suggests that the KINEROS2 model may provide useful estimates of relative change in peak runoff when physically-realistic values of roughness are used. Therefore, initial post-fire roughness will need to be reduced to bare, or near bare conditions to produce realistic estimates of runoff peak.

This and other studies have found that observed changes in runoff volume following fire are less pronounced than the changes in peak runoff rates on forested watersheds. Unfortunately, change analysis is hampered by a lack of pre-fire data on burned watersheds. At Marshall Gulch, data from before and after the Aspen fire supported the findings of Springer and Hawkins (this volume) that showed limited change in runoff volume and a watershed with ‘complacent’ behavior whereby CN values increase with increasing rainfall rates. An accompanying paper, Goodrich et al (this volume), suggests some possible Curve Number values for post-fire conditions based on changes in cover that result in smaller changes in CNs than are currently selected by experience.

Large changes were observed in discharge rates following the Aspen Fire at Marshall Gulch. Furthermore, the fact that the ratio of runoff peak to runoff average was observed to change from 3.6 pre-fire to 4.9 after the fire suggests that the runoff generating mechanisms at Marshall Gulch have been changed by the fire.

While KINEROS2 is not structured to simulate the runoff processes observed in heavily forested conditions, the erosion estimated by simulating Hortonian overland flow should provide an estimate that would be higher than the hillslope erosion that would occur as a result of subsurface storm flow and return flow under forested conditions.

One area requiring further study is the change in peak discharge to average ratio noted at Marshall Gulch. What physical processes control this ratio and why should they change in post-fire conditions? Another area needing further investigation is an analysis of the geometric partitioning effect on runoff peak and sediment discharge. Studies indicate that there can be scale dependence under some conditions (Goodrich, 1990; Canfield and Goodrich (in press)).

## 8.0 AGWA-SWAT Application to the 2003 Aspen Fire near Tucson, Arizona

The overlay of land cover and soils allows AGWA to select a parameter set appropriate for that given land cover on that soil. The addition of a burn-severity map allows further characterization of hydrologic response based on the land cover, soils classification and burn severity. A critical element in using AGWA for post-fire assessments is translating a burn severity map into relationships that can be used to alter infiltration and erosion model parameters. This issue is discussed in more detail in a companion paper by Canfield et al. (this volume). In hydrologic-model terms, different CN values, and different post-fire roughness values can be selected based on the new classification. The burn severity map for the 2003 Aspen fire (Figure 8.1) illustrates a complex mosaic of low, moderate, and high severity burns.

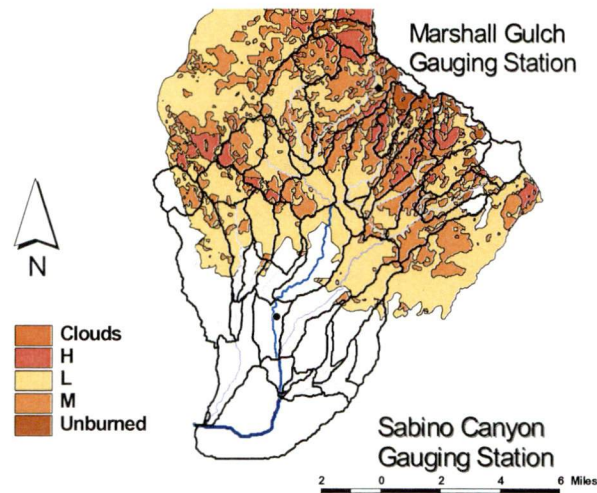
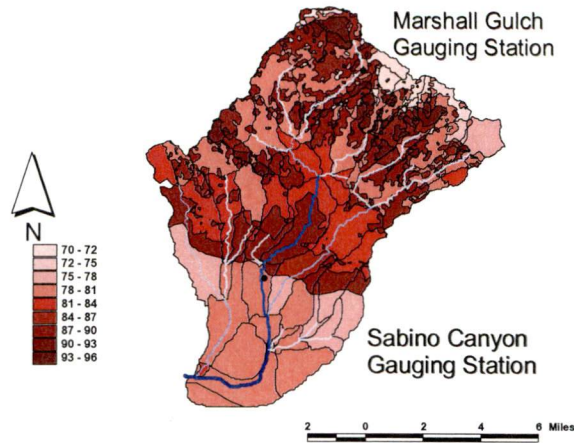

**Figure 8.1– Burn Severity Map of Aspen Fire on the Sabino Canyon Watershed**

By using a GIS, this information can be used to develop a complex mosaic of CNs, which can allow users to more accurately reflect hydrologic conditions within the model representation. The traditional method of implementing the CN technique (USDA, 1986) uses a spatially-weighted average CN, which can be used to describe the hydrologic response of a watershed. Since runoff is highly sensitive to CN, small differences in CN can result in big differences in runoff (Hawkins, 1975). A revised post-fire CN map for the Sabino Canyon watershed is given in Figure 8.2.

To fully utilize the revised CN map, the watershed must be partitioned into model elements small enough to represent a single hydrologic soil group, land-cover and burn-severity classification. Therefore, AGWA should not be used to partition a watershed at a more coarse level than the default 2.5%, and there may be situations, where this level is too coarse.

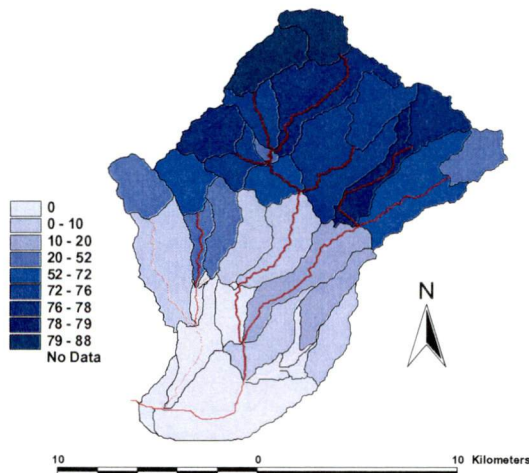



**Figure 8.2 – Revised Curve Number Map of Aspen Fire on the Sabino Canyon Watershed**

A second change that occurs on hillslopes is a change in hillslope roughness. Evaluation of roughness in the companion paper (Canfield et al, this volume) indicates that post-fire roughness on hillslopes can be over an order of magnitude lower in forested areas following fire. Rather than fix roughness separately for all soil/cover/complexes, the post-fire evaluation with AGWA sets roughness at a value reasonable for bare soil ( $n = 0.011$ ; Engman, 1986). Selection of this value allows for more than an order of magnitude change in extremely rough environments, such as conifer forests.

The revised CN map in Figure 8.2 was used to generate SWAT model parameters for a one year simulation driven by a historical observed climatic record. The resulting difference in annual water yield by subwatershed area is illustrated in Figure 8.3. For this simulation, watershed roughness and infiltration parameters were held constant. This is unrealistic as the watershed recovers over time, but the objective is to evaluate how average annual runoff would change in a post-fire regime. Chapter 7 presents time-



**Figure 8.3 – First Year Post-fire Water Yield Difference Modeled by SWAT-AGWA (% change)**

varying relationships (first post-fire day equals day one) for KINEROS2 parameters of hillslope hydraulic roughness and saturated hydraulic conductivity based on optimized post-fire observations at Starmer Canyon near Los Alamos, New Mexico.

Post-fire simulations from design or observed storms can also be spatially compared to pre-fire simulations driven with the same climate for various simulation outputs (e.g. peak runoff rate, total storm volume, total sediment transport, erosion, etc.). These differences can be displayed in percentage difference terms from the pre-fire case, or in terms of absolute differences.

### Conclusions

Estimation of post-fire hydrologic response and change analysis is an important step in developing a plan to remediate potential post-fire flooding and erosion. The GIS-based AGWA tool ([www.tucson.ars.ag.gov/agwa](http://www.tucson.ars.ag.gov/agwa)) allows the use of readily available spatial datasets to perform pre-fire hydrologic analysis using empirical (SWAT) and process-based (KINEROS2) hydrological models. If a burn-severity map is available, estimates of runoff volume can be made by modifying post-fire CNs. An application of AGWA-SWAT is illustrated using available data sets and a burn-severity map on the 2003 ASPEN fire near Tucson, AZ. A relationship between cover and CN provides a basis for estimating post-fire changes in CNs. The estimated changes in CNs are smaller than those derived from experience and used in many post-fire BAER analyses. However, they agree more with the observed changes in post-fire runoff volume, which show that the change in runoff volume is small relative to the large change in post-fire peak runoff. Therefore, a second modification in AGWA is to drastically decrease hillslope roughness, which increases peaks without a large increase in runoff volume. An application of KINEROS to the Starmer Canyon dataset at Los Alamos (Canfield et al, this volume) shows that hillslope roughness approximates bare conditions following the fire, and rapidly recovers. In summary the AGWA tool offers the capability of rapid post-fire watershed assessments to more effectively target remediation efforts. We would welcome, and assist in, the application of AGWA by resource managers and BAER teams.

## 9.0 Suggested Modifications to KINEROS2 to Account for Fire

### Estimated Post-Fire Roughness Values

Using the cover values for natural covers and estimated hillslope roughness for those covers as listed in table 1.2, the relationship illustrated in Figure 9.1 was determined for roughness value as a function of cover values.

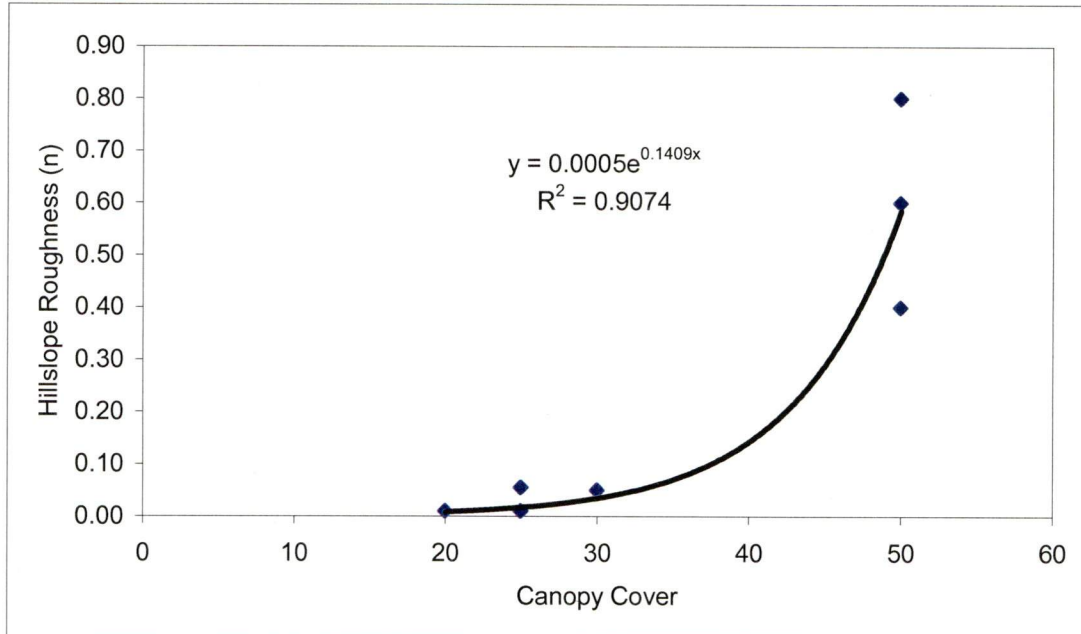

**Figure 9.1 – Hillslope Roughness as a Function of Canopy Cover**

Using these values, table 5.1 could be updated to estimate post-fire hillslope roughness values as a function of canopy cover. It should be noted that hillslope roughness is related to ground cover and litter, but that litter is produced by the canopy, and one would expect environments with more canopy cover to also have more ground cover.

**Table 9.1 Estimated Curve Number, Cover, Roughness and Interception Values for Burned and Unburned Conditions**

Class	Name	A	B	C	D	Cover	Int	n
11	Open Water	100	100	100	100	0	0	0.000
12	Perennial Ice/Snow	98	98	98	98	0	0	0.000
21	Low Intensity Residential	77	85	90	92	15	0.1	0.150
22	High Intensity Residential	81	88	91	93	10	0.08	0.120
23	Commercial/Industrial/ Transportation	89	92	94	95	2	0.05	0.011
31	Bare Rock/Sand/Clay	96	96	96	96	2	0	0.011
32	Quarries/Strip Mines/Gravel Pits	78	85	90	92	2	0	0.010
33	Transitional	72	82	87	90	20	0	0.010

41	Deciduous Forest	55	55	75	80	50	1.15	0.400
42	Evergreen Forest	55	55	70	77	50	1.15	0.800
43	Mixed Forest	55	55	75	80	50	1.15	0.600
51	Shrubland	63	77	85	88	25	3	0.055
61	Orchards/Vinyards/Other	77	77	84	88	70	2.8	0.040
71	Grasslands/Herbaceous	49	69	79	84	25	2	0.130
81	Pasture/Hay	68	79	86	89	70	2.8	0.400
82	Row Crops	72	81	88	91	50	0.76	0.170
83	Small Grains	65	76	84	88	90	4	0.170
84	Fallow	76	85	90	93	30	0.5	0.050
85	Urban/Recreational Grasses	68	79	86	89	90	2.5	0.410
91	Woody Wetlands	85	85	90	92	70	1.15	0.600
92	Emergent Herbaceous Wetlands	77	77	84	90	70	1.15	0.600
41l	Deciduous Forest	59	60	78	82	43	1.15	0.199
42l	Evergreen Forest	49	71	80	85	43	1.15	0.199
43l	Mixed Forest	59	60	78	82	43	1.15	0.199
51l	Shrubland	65	79	86	89	21	1.15	0.010
41m	Deciduous Forest	65	65	80	85	34	1.15	0.060
42m	Evergreen Forest	55	76	82	88	34	1.15	0.058
43m	Mixed Forest	65	65	80	85	34	1.15	0.058
51m	Shrubland	68	82	88	90	17	1.15	0.005
41h	Deciduous Forest	70	71	83	87	25	1.15	0.017
42h	Evergreen Forest	60	82	85	90	25	1.15	0.017
43h	Mixed Forest	70	71	83	87	25	1.15	0.017
51h	Shrubland	73	88	91	91	12	1.15	0.017

Note: l - low severity burn  
m - moderate severity burn  
h - high severity burn

It should be noted that the estimated roughness values for high severity burn approach the value for bare conditions. Therefore, the values of the table seem reasonable for forested conditions, and may be appropriate for estimating moderate and low severity burned forest conditions. However, the calculated values for shrubland are unrealistically low, and so should be set to a value no lower than bare conditions.

#### Post-Fire Ks Estimates

At this point, Ks values have not been estimated based on burn severity and cover estimates.

## 10. Suggested Modifications to AGWA-SWAT to Account for Fire

### Modifications to AGWA SWAT

The estimated changes in CN and roughness for burned conditions described in Table 9.1 should serve as a basis for implementing SWAT in AGWA for burned conditions. However, since runoff velocities in SWAT assume a given rainfall excess, the estimates of peak runoff and erosion may be underestimated.

### Impact of SWAT Overland Flow Calculation on Runoff Velocity

**Estimates of Overland Flow Travel Time in SWAT:** In the SWAT model overland flow can be described by the following equation:

$$v = \frac{q_{ov}^{0.4} * slp^{0.3}}{n^{0.6}}$$

Where  $v$  is the overland flow velocity (m/s),  $q_{ov}$  is the average overland discharge rate ( $m^3/s$ ),  $slp$  is the hillslope slope, and  $n$  is the manning roughness value. This is simply the solution of the kinematic wave for overland flow ( ). In SWAT, 6.35 mm/hr (1/4 inch/hr) is assumed to be rainfall excess rate, the  $q_{ov}$  value can be calculated for the length of the slope, and the following formulation can be used.

$$v = \frac{0.005L^{0.4} * slp^{0.3}}{n^{0.6}}$$

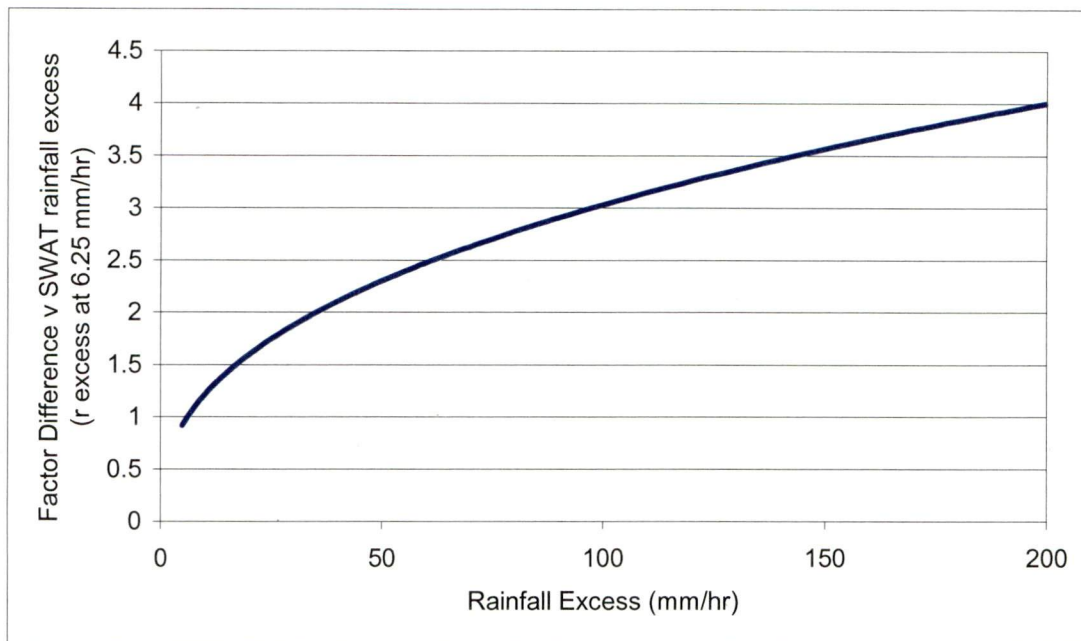

**Figure 10.1 Relative Difference In Rainfall Excess on Overland Flow Velocity**

SWAT uses rainfall excess calculated at 6.25 mm/hr in order to calculate runoff rate. Using the formulation of runoff velocity calculated in SWAT, runoff rate increases as a function of rainfall excess rate to the 0.4 power. In the southwest, rainfall excess can exceed 100 mm/hr in some situations. As noted in figure 10.1, the velocity of overland flow can be three times greater than the rate calculated in SWAT for rainfall excess of 100 mm/hr. Furthermore, at rainfall excess rates of 35 mm/hr, which are commonly exceeded in the desert southwest, the SWAT-calculated runoff rate is off by a factor of two. Therefore, SWAT-calculated peak runoff rate may be below the value calculated using the kinematic wave formulation for dynamic rainfall excess calculation.

## **11.0 Acknowledgements**

Everett Springer provided the data set from Starmer Canyon at Los Alamos. The insights of Everett and Richard Hawkins were invaluable in understanding the hydrologic response of these burned watersheds. Hoshin Gupta provided valuable insight into calibration of hydrologic models and supplied the FORTRAN SCEUA code that was used for optimization of the KINEROS2 runs at Starmer Canyon. Andy Wigg from Pima County, (Arizona) Flood Control District provided rainfall and runoff data for Marshall Gulch. Salek Shafiqullah, USFS-Coronado National Forest, provided a burn severity map for the Aspen and Bullock fires and valuable insight into the USFS BAER approach. Support for this research was provided by the USDA-ARS Headquarters Post Doctoral Program, the US-EPA Landscape Ecology Branch, and in part by SAHRA under the STC Program of the National Science Foundation, Agreement No. EAR-9876800. This support is gratefully acknowledged

### ***Disclaimer***

Any opinions, findings, and conclusions or recommendations expressed in this material are those of the author(s) and do not necessarily reflect the views of SAHRA or of the National Science Foundation.

## 12.0 References

- Anderson, H. W., M. D. Hoover, and K. G. Reinhart. 1976. "Forests and water: effects of forest management on floods, sedimentation, and water supply." *General Technical Report PSW-18*, USDA, Forest Service, Berkeley, CA.
- Arnold, J.G., J. R. Williams, R. Srinivasan, K.W. King, and R. H. Griggs, 1994. "SWAT- Soil Water Assessment Tool." USDA, Agricultural Research Service, Grassland, Soil and Water Research Laboratory, Temple, Texas.
- Canfield, H.E. and Goodrich, D.C. (in press) "The Impact of Parameter Lumping and Geometric Simplification in Modeling Runoff and Erosion in the Shrublands of Southeast Arizona." (accepted for Publication in *Hydrological Processes*).
- Canfield, H.E. and Lopes, V.L. (2004) "Parameter Identification in a Two Multiplier Sediment Yield Model." *Journal of the American Water Resources Association*. 40(2), 321-332
- Canfield, H.E., Goodrich, D.C., and Burns, I.S. (2005). "Application of Models to Predict Post-fire Runoff and Sediment Transport at the Watershed Scale in Southwestern Forests". Amer. Society of Civil Eng. Watershed Management Conference, Williamsburg, VA, July 19-22, 2005 CD Proceedings, p, 1-12.
- DeBano, L. F., Neary, D.G. and Ffolliott, P.F. (1998) *Fire's Effects on Ecosystems*. John Wiley and Sons, New York. 338p.
- DeBano, L. F.; Ffolliott, P. F.; Baker, M. B., Jr. (1996) "Fire Severity Effects on Water Resources. In: Ffolliott, P. F.; DeBano, L. F.; Baker, M. B., Jr.; Gottfried, G. J.; Solis-Garza, G.; Edminster, C. B.; Neary, D. G.; Allen, L. S.; Hamre, R. H., tech. coords. *Effects of fire on Madrean province ecosystems—A symposium proceedings*. Gen. Tech. Rep. RM-289. Fort Collins, CO: U.S. Department of Agriculture, Forest Service, Rocky Mountain Forest and Range Experiment Station: 77-84.
- Duan, Q., Sorooshian, S. and Gupta, V.K. (1992) "Effective and Efficient Global Optimization for Conceptual Rainfall-runoff Models." *Water Resources Research*. 28(4):1015-1031
- Dunne, T. and Leopold, L.B. (1978) *Water in Environmental Planning*. W.H. Freeman and Company. New York. 818 p.
- Engelund, F. and Hansen, E. (1967) *A Monograph on Sediment Transport in Alluvial Streams*, Teknisk Forlag, Copenhagen, 62 pp.
- Engman, E.T. (1986) "Roughness Coefficients for Routing Surface Runoff." *Journal of Irrigation and Drainage Engineering*, 112(1). 39-53
- Goodrich, D.C., Canfield, H.E., Burns, I.S., Semmens, D.J., Miller, S.N., Hernandez, M., Levick, L.R., Guertin, D.P., and Kepner, W.G., (2005.) Rapid post-fire hydrologic watershed assessment using the agwa gis-based hydrologic modeling tool. Proc. Amer. Society of Civil Eng. Watershed Management Conference, Williamsburg, VA, July 19-22, 2005 CD Proceedings, p, 1-12.
- Goodrich, D.C. (1990) *Geometric Simplification of a Distributed Rainfall-runoff Model over a Range of Basin Scales*. Ph.D. Dissertation. Hydrology Department. University of Arizona. Technical Reports NO. HWR 91-010. 361pp.
- Hawkins (2004 pers. comm.)



- Hawkins, R.H. (1993) "Asymptotic Determination of Curve Numbers from Rainfall – Runoff Data." *Journal of Irrigation and Drainage Engineering* - ASCE, 119(2), 334-345.
- Hawkins, R.H. (1975). "The Importance of Accurate Curve Numbers in the Estimation of Storm Runoff." *Water Resources Bulletin*. 11(5).
- Hendricks, B. A.; Johnson, J. M. (1944) "Effects of Fire on Steep Mountain Slopes in Central Arizona." *Journal of Forestry*. 42: 568-571.
- Hernandez, M., Miller, S.N., Goodrich, D.C., Goff, B.F., Kepner, W.G., Edmonds, C.M., and Jones, K.G. (2000). "Modeling Runoff Response to Land Cover and Rainfall Spatial Variability in Semi-arid Watersheds." *J. Environmental Monitoring and Assessment*, 64:285-298.
- Kepner, W.G., Semmens, D.J., Bassett, S.D., Mouat, D.A., Goodrich, D.C. (2004). "Scenario Analysis for the San Pedro River, Analyzing Hydrological Consequences of a Future Environment." *J. Environmental Monitoring and Assessment*, 94:115-127.
- McLin, S. G., Springer, E. P., and Lane, L. J. (2001). "Predicting Floodplain Boundary Changes Following the Cerro Grande Wildfire." *Hydrological Processes*, 15(15): 2967-2980.
- Miller, S.N., Kepner, W.G., Hernandez, M., Miller, R.C., Goodrich, D.C., Heggem, D.L., Mehaffey, M.L., Devonald, F.K., and Miller, W.P. (2002). "Integrating Landscape Assessment and Hydrologic Modeling in Land Cover Change Analysis." *J. American Water Resources Association*, 38(4):915-929.
- Nash, J.E. and Sutcliffe, J.V. (1970) "River Flow Forecasting Through Conceptual Models I. A Discussion of Principles." *Journal of Hydrology*. 10:282-290
- Robichaud, P.R. Beyers, J. L., Neary, D.G., (2000) *Evaluating the Effectiveness of Postfire Rehabilitation Treatments*. United States Forest Service Rocky Mountain Research Station General Technical Report RMRS-GTR-63
- Smith, R.E., Goodrich, D. C., Woolhiser, D.A. and Unkrich, C.L. (1995) "KINEROS - A Kinematic Runoff and Erosion Model", Ch. 20. In: *Computer Models of Watershed Hydrology*, V.J. Singh (Editor), Water Resources Publications, 697-632
- Smith, R. E. and Quinton, J. N. (2000). "Dynamics and Scale in Simulating Erosion by Water". In: Schmidt, J. (Editor). *Soil Erosion: Application of Physically Based Models*. Berlin: Germany, Springer-Verlag, pp.283-294
- Smith, R. E. and Parlange, J. Y. (1978). "A Parameter Efficient Hydrologic Infiltration Model." *Water Resources Research*, 14(3):533-538.
- Springer, E. and Hawkins, R.H. (2005). "Curve Number Peakflow Response Following the Cerro Grande Fire on a Small Watershed". Amer. Society of Civil Eng. Watershed Management Conference, Williamsburg, VA, July 19-22, 2005 CD Proceedings, p, 1-12.
- USDA, (1986) *Urban Hydrology for Small Watersheds*. United States Department of Agriculture Natural Resources Conservation Service Technical Release 55.
- Woolhiser, D.A., Smith, R.E. and Goodrich, D.C. (1990) "*A Kinematic Runoff and Erosion Model*": Documentation and user manual. Report #77. Agricultural Research Service, United States Department of Agriculture 130 pp.

# Predicting the probability and volume of postwildfire debris flows in the intermountain western United States

Susan H. Cannon<sup>1,†</sup>, Joseph E. Gartner<sup>1</sup>, Michael G. Rupert<sup>2</sup>, John A. Michael<sup>1</sup>, Alan H. Rea<sup>3</sup>, and Charles Parrett<sup>4</sup>

<sup>1</sup>U.S. Geological Survey, Box 25046, Denver Federal Center, MS 966, Denver, Colorado 80225, USA

<sup>2</sup>U.S. Geological Survey, 201 East 9th Street, Pueblo, Colorado 81003, USA

<sup>3</sup>U.S. Geological Survey, 230 Collins Road, Boise, Idaho 83702, USA

<sup>4</sup>U.S. Geological Survey, Placer Hall, 600 J Street, Sacramento, California 95819, USA

## ABSTRACT

Empirical models to estimate the probability of occurrence and volume of postwildfire debris flows can be quickly implemented in a geographic information system (GIS) to generate debris-flow hazard maps either before or immediately following wildfires. Models that can be used to calculate the probability of debris-flow production from individual drainage basins in response to a given storm were developed using logistic regression analyses of a database from 388 basins located in 15 burned areas located throughout the U.S. Intermountain West. The models describe debris-flow probability as a function of readily obtained measures of areal burned extent, soil properties, basin morphology, and rainfall from short-duration and low-recurrence-interval convective rainstorms. A model for estimating the volume of material that may issue from a basin mouth in response to a given storm was developed using multiple linear regression analysis of a database from 56 basins burned by eight fires. This model describes debris-flow volume as a function of the basin gradient, aerial burned extent, and storm rainfall. Applications of a probability model and the volume model for hazard assessments are illustrated using information from the 2003 Hot Creek fire in central Idaho. The predictive strength of the approach in this setting is evaluated using information on the response of this fire to a localized thunderstorm in August 2003. The mapping approach presented here identifies those basins that are most prone to the largest debris-flow events and thus provides information necessary to prioritize areas for postfire erosion mitigation, warnings, and prefire management efforts throughout the Intermountain West.

<sup>†</sup>E-mail: cannon@usgs.gov

## INTRODUCTION

Methods for assessing the potential for debris flows from basins burned by wildfires over extensive areas are needed to rapidly assess hazards and to prioritize locations for prefire restoration efforts. Here, we describe a set of models that rely on data readily available immediately after a fire and that can be implemented in a geographical information system (GIS) to assess postfire debris-flow hazards. The assessments identify the probability that given basins will produce debris flows, and they estimate the potential volume of the debris flows at the basin outlet. This approach addresses two of the fundamental questions in debris-flow hazard assessment: where might debris flows occur and how big might they be?

The increased occurrence of catastrophic wildfires in the western United States (Westerling et al., 2006) and the encroachment of development into fire-prone ecosystems have highlighted the need for methods to quantify the potential hazards posed by debris flows produced from burned watersheds. Science-based information on postwildfire debris-flow hazards is necessary for federal, state, and local agencies to mitigate the impacts of fire on people and their property, and on natural resources. Identification of potential debris-flow hazards from burned drainage basins is necessary to make appropriate decisions for the design and location of mitigation measures and to develop effective emergency warnings and evacuation timings and routes. Application of predictive models for debris-flow hazards before the occurrence of wildfires with a projected burn severity distribution can help to identify potentially hazardous drainage basins and thus direct planning strategies that minimize the potential for catastrophic fires in those areas.

Fire-related debris-flow hazard assessments conducted in the past have relied on local knowledge of the response of unburned basins

(e.g., A.J. Gallegos, USDA Forest Service, 1995, written commun.), on site-specific case studies of the known response of nearby burned basins (e.g., R. Gould, USDA Forest Service, 1997, written commun.; J.V. DeGraff, USDA Forest Service, 1997, written commun.), and on assessments of flooding potential with assumed sediment bulking factors (e.g., Biddinger et al., 2003; R. Gould, USDA Forest Service, 1997, written commun.). For example, Elliott et al. (2004) linked modeled flood hydrographs to a two-dimensional flood and debris-flow routing model (FLO-2D; O'Brien, 1993) and, using assumed postfire sediment concentrations, delineated potential areas of unconfined debris-flow inundation on alluvial fans and valley floors. Given the present lack of physical understanding of the factors that control debris-flow generation from burned basins, it is not uncommon for workers to rely on assumed effects. Mitsopoulos and Mironidis (2006) totaled assumed relative rankings of the effects of burn severity, hillslope gradients, and geologic materials to categorize relative hazards posed by debris flows in a Mediterranean setting. Spittler (1995) and Wohl and Pearthree (1991) made observations of the conditions that existed at the time of debris-flow occurrence and suggested that these factors determine a debris-flow response. For example, Spittler (1995) identified friable bedrock units; fractured bedrock; cohesionless soils, colluvium and alluvium; long regular slopes having gradients greater than 65% that are denuded of vegetation; concentrations of dry ravel; development of a continuous water-repellent soil; and removal of woody structural support from stream channels as those factors that control the debris-flow response of burned areas. Cannon and Gartner (2005), Weight and Johansen (2004), Rupert et al. (2003), and Cannon (2001) used uni- and bivariate statistical evaluations of measurements of these potential explanatory variables to identify specific conditions that are related to debris-flow occurrence.

The approach described here advances the previous qualitative and statistical evaluations by first providing a statistical identification of the storm-specific conditions that most strongly influence the generation of postfire debris flows and the magnitude of the flows, and then by presenting integrated, multivariate statistical models that characterize the combined effects of these conditions on postfire debris-flow probability and magnitude.

### Fire-Related Debris-Flow Hazards

Wildfire can have immediate and profound effects on the hydrologic response of a watershed. Consumption of the rainfall-intercepting canopy and of the soil-mantling litter and duff, intensive drying of the soil, generation of vegetative ash, and the enhancement or formation of water-repellent soils and/or surface sealing of soil pores by wood ash can result in decreased rainfall infiltration and significantly increased runoff and movement of soil (e.g., Kinner and Moody, 2007; Shakesby and Doerr, 2006; Neary et al., 2005; Wondzell and King, 2003; Martin and Moody, 2001; Moody and Martin, 2001a; Doerr et al., 2000; Spittler, 1995; Troxell and Peterson, 1937). Smooth and continuous runoff paths resulting from the removal of vegetation can allow for rapid and pervasive overland flow (Meyer, 2002). Combustion of soil-binding organic material promotes dry ravel of noncohesive soils and channel loading (Swanston, 1991; Wells, 1987). Increased runoff can also erode significant volumes of material from hillslopes as rills and gullies, and from channels, either by bank failure or channel bed erosion (Santi et al., 2008; Wondzell and King, 2003; Moody and Martin, 2001b). The result of rainfall on burned basins is often the transport and deposition of large volumes of sediment, both within and down-channel from the burned area.

Debris flows are among the most hazardous consequences of rainfall on burned hillslopes. Debris flows pose a hazard distinct from other sediment-laden flows because of their unique destructive power. They can occur with little warning, exert great impulsive loads on objects in their paths, and strip vegetation, block drainage ways, damage structures, and endanger human life (Iverson, 1997). The deaths of 16 people during the 24–25 December 2003 storm and subsequent runoff from burned hillslopes in Southern California highlight the most drastic consequences of postwildfire debris flows (Chong et al., 2004). In addition to the lives lost, \$23.5 million was spent to repair flood and debris-flow damage and to empty debris basins (Pat Mead, FEMA, 2004, personal commun.).

From field observations of debris flow-producing basins following fires in Yellowstone National Park in 1988, Meyer et al. (1995) described a process of debris-flow generation by progressive bulking of runoff by sediment eroded from hillslopes and channels, rather than discrete slope failures. Cannon and Gartner (2005) conducted a field and aerial photographic study of 210 recently burned debris flow-producing basins throughout the intermountain western United States that demonstrated the majority of postfire debris flows initiated through such a process. The flows occurred within 2 years after wildfires in response to short-duration (<1 h) storms with low-recurrence intervals (<2–10 years) (Cannon et al., 2008). Detailed surveys of 46 postfire debris flow-producing basins in Colorado, Utah, and southern California led Santi et al. (2008) to conclude that channel erosion and scour were the dominant sources of material for these flows.

Although infiltration-triggered landsliding can occur in burned basins, most landslide failures occur in response to prolonged and long-recurrence-interval rainfall events, and they typically contribute just a small proportion of the total volume of material transported from the basin (Cannon and Gartner, 2005; Cannon et al., 2001; Scott, 1971). These findings point to the relative importance of runoff-dominated, rather than infiltration-dominated, processes of debris-flow initiation in recently burned basins, and they indicate that methods to map landslide potential for unburned basins based on traditional slope stability analyses are inappropriate for assessments of recently burned areas. Such analyses may be appropriate when considering the response to storms with long recurrence intervals or to time periods of years to decades that allow for root-strength decay.

### APPROACH AND METHODS

Studies of the erosional response of recently burned basins throughout the Intermountain West of the United States reveal that not all basins produce debris flows; most burned watersheds respond to even heavy rainfall by producing sediment-laden floods (Cannon, 2001). Debris flows, however, represent the more destructive end of the potential response spectrum and thus warrant particular attention. We thus need a way to identify basins that will specifically produce debris flows rather than simply sediment-laden floods. Here, we take the approach of defining a set of conditions that identify those basins that are specifically susceptible to debris-flow activity. When debris flows are generated through the process of progressive sediment bulking, the volume,

velocity, and sedimentologic characteristics of a debris flow at any given point along a drainage network will depend on the formation processes and characteristics in the contributing basin area above the point (Cannon et al., 2001, 2003a). For this reason, we use the basin form as the unit of choice for evaluation, rather than the pixel (as is commonly used in GIS-based hillslope stability analyses).

We used data collected from recently burned basins throughout the U.S. Intermountain West (Gartner et al., 2005) (Fig. 1) to develop multivariate statistical models that can predict both the probability that a selected basin will produce debris flows and the potential volume that may issue from the basin mouth. The probability of debris-flow occurrence and estimates of volumes are considered to be functions of combinations of different measures of soil properties, basin characteristics, burn severity, and rainfall conditions. Application of the statistical models in a GIS to produce maps that show potential debris-flow hazards for a given storm event is illustrated using data from the 2003 Hot Creek fire in central Idaho. We used a procedure described by Chung and Fabbri (2003) to characterize the success and predictive effectiveness of the probability models and to identify the models that best predicted the response of burned basins in this setting. The models presented here can be used to identify those recently burned basins in the Intermountain West that, in response to given rainfall events, are most likely to produce debris flows (have estimated high probabilities of occurrence) and to estimate the likely volumes of material in the debris flows.

### Debris-Flow Probability Models

Logistic regression multivariate statistical analyses (e.g., Hosmer and Lemeshow, 2000; Helsel and Hirsch, 2002) using data measured from 388 basins in 15 recently burned areas throughout the intermountain western United States were used to identify the variables that best indicate a susceptibility to debris flows. The analyses were further used to develop models that characterize the probability of debris-flow occurrence for recently burned basins (Fig. 1). The database to develop the models consists of a set of independent variables that potentially characterize runoff processes in burned basins (e.g., Moody et al., 2008; Beven, 2000). These variables include measures of basin gradient, basin aspect, burn severity distribution within the basin, soil properties, and storm rainfall conditions in basins that were characterized either as having produced debris flows, sediment-laden floods, or no response (Gartner et al., 2005).

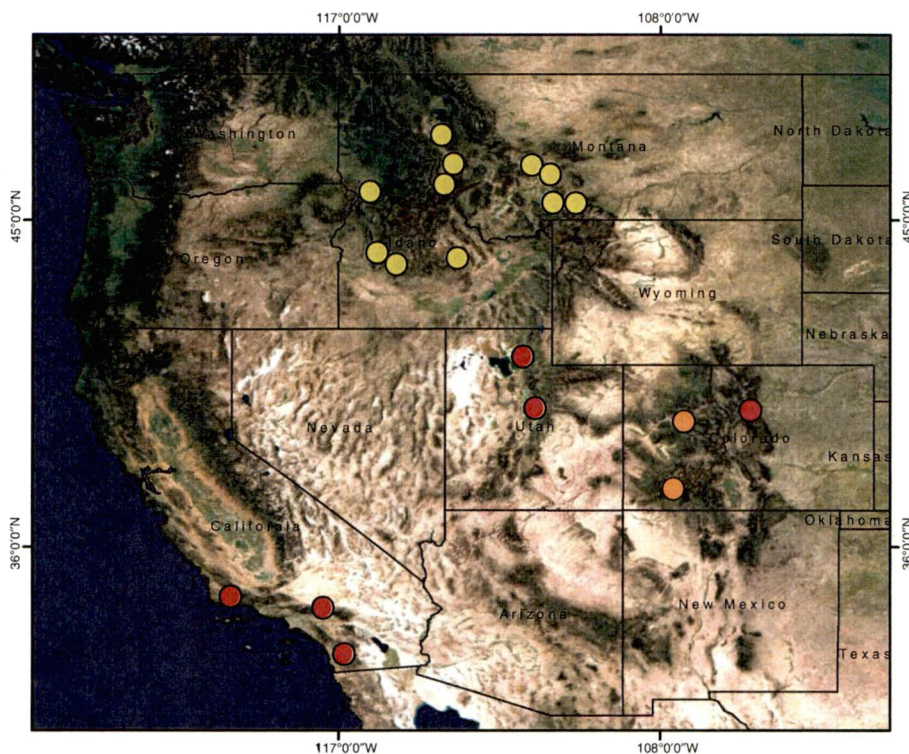

**Figure 1.** Map showing locations of basins used to develop models for the probability of debris-flow generation (yellow dots), for estimates of debris-flow volume (red dots), or both models (orange dots).

Basins were defined by the contributing area above an outlet located at a break in slope between a mountain front and a valley (or at the location of a general transition between erosion and deposition) or within the basin at a road crossing or above an identified value at risk. Defined basins ranged in area between 0.01 and 103 km<sup>2</sup>, and the majority of basins were less than 1.0 km<sup>2</sup> in area (Fig. 2). Sixty-four of the 388 basins, or 16%, showed a debris-flow response. Low-order tributaries produced most debris flows, as indicated by the small mean (1.7 km<sup>2</sup>) and median (0.2 km<sup>2</sup>) areas for debris flow-producing basins. For this sample of basins in the Intermountain West, debris flows were not observed at the outlets of basins greater than ~30 km<sup>2</sup> in area (Fig. 2).

Field observations at basin outlets made within 1 wk of storms were used to determine if a basin produced debris flows. Debris-flow deposits were identified as indurated, poorly sorted, unstratified materials with some fine-grained matrix; levees and boulder berms lining the flow path with indurated, unsorted matrix material within the deposits; and an indurated muddy veneer lining the flow path and coating boulders and vegetation (Pierson, 2005). Deposits other than levees and boulder berms (which

can lack matrix material along margins) that showed stratification or sorting, or that lacked matrix materials in any part of the deposit, were considered to be the result of sediment-laden streamflow, rather than debris flow. In some cases, observations of the surface of deposits indicated that the source might be a sediment-laden flood (e.g., sorted, clean sands or boulder berms), but matrix material that was found well within the deposits indicated a debris-flow origin (Pierson, 2005; Cannon, 2001; Meyer and Wells, 1997).

Five measures of basin gradient were compiled for use as potential explanatory variables using either 30 m or 10 m digital elevation models (DEMs), depending on availability. These measures include: (1) the average basin gradient, (2) percentage of basin area with slopes greater than or equal to 30%, (3) percentage of basin area with slopes greater than or equal to 50%, (4) basin ruggedness (change in basin elevation divided by the square root of the basin area; Melton, 1965), and (5) relief ratio (change in basin elevation divided by the channel thalweg length).

Basin aspect was quantified from either 10 or 30 m DEMs as the average direction, in azimuth degrees from the north, that a basin faces using the ArcGIS spatial analyst tool.

Five measures of burn severity for each basin were characterized using maps of burn severity generated from the normalized burn ratio (NBR), as determined from Landsat Thematic Mapper data (Key and Benson, 2006). These maps reflect the relative changes in pre- and immediately postfire vegetation cover. Measures of burn severity compiled for use as potential explanatory variables include: percentage of the basin area burned at low severity, percentage of the basin area burned at moderate severity, percentage of the basin area burned at high severity, percentage of the basin area burned at high and moderate severities, and percentage of basin area burned.

In addition to the relative changes in vegetation coverage in response to the fire, the burn severity classifications are considered to reflect relative measures of the distribution of water-repellent soils (Parsons et al., 2002). The extent of burn severity and basin area at different gradients were characterized as percentages (0%–100%) because they were used to calculate a relative probability that also varied between 0% and 100%.

Soil properties for each basin were compiled from two sources. First, soil-particle sizes were measured from samples of burned surficial soils collected within the basins. The soil-size properties characterized from the grain-size distribution include: mean particle size, median particle size, sorting of the grain-size distribution, and skewness of grain-size distribution, as described by Inman (1952). Second, various properties of unburned soils were compiled for each basin from the 1:250,000 STATSGO soils database (Schwartz and Alexander, 1995). Although the scale of this database indicates that it provides only a broad characterization of soil properties, it is the only source of consistent soil information available for the entire Intermountain West. This database was used to compile the following soil properties for each basin: percent clay content, available water capacity, permeability, erodibility (k-factor), percent organic matter, soil thickness, liquid limit, hydrologic group, and hydric capacity. Definitions of these properties are shown in Table 1.

Properties of the geologic material underlying the soils were not considered for use as explanatory variables in this study because the runoff and erosion leading to the generation of debris flow involve primarily surficial material, and because rock type did not appear as a significant variable in previous studies of fire-related debris-flow processes (Gartner, 2005; Cannon et al., 2003b; Rupert et al., 2003).

Data from tipping-bucket rain gauges located within 2 km of each basin were compiled and used to develop the following potential

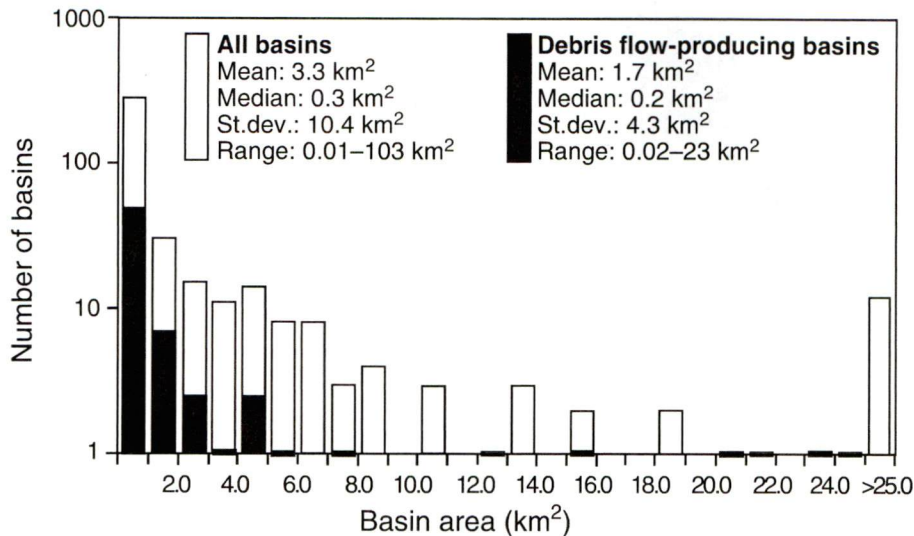

Figure 2. Histogram showing areas of recently burned basins used in development of the debris-flow probability model (open bars), and areas of basins that produced debris flows (filled bars).

TABLE 1. DEFINITIONS OF SOIL PROPERTIES INCLUDED IN THE STATSGO SOIL DATABASE (SCHWARTZ AND ALEXANDER, 1995)

Soil property	Definition
Percent clay content	Clay content of the soil or horizon, expressed as a percentage of material less than 2 $\mu$ m in size.
Available water capacity	The volume of water that should be available to plants if the soil, exclusive of rock fragments, was at field capacity.
Permeability	The amount of water that will move downward through a unit area of saturated soil in unit time under a unit hydraulic gradient.
Erodibility (k-factor)	A relative index of the susceptibility of bare, cultivated soil to particle detachment and transport by rainfall.
Percent organic matter	The amount of organic material in the soil, in percent by weight.
Soil thickness	The weighted average thickness of all soil layers.
Liquid limit	The water content at the change between the liquid and plastic state of the soil.
Hydrologic group	The minimum steady-ponded infiltration rate for bare ground. Ratings are composed of four categories, A through D, with A having the highest saturated hydraulic conductivity.
Hydric capacity	The tendency for the soil to hold water. Soils are rated as hydric or nonhydric.

explanatory variables: total storm rainfall, storm duration, average storm rainfall intensity, peak 10 min rainfall intensity, peak 15 min rainfall intensity, peak 30 min rainfall intensity, and peak 60 min rainfall intensity.

Rainfall conditions were included in the evaluation of debris-flow probability because they are the driver of the system; the response of a given basin with a particular set of characteristics is directly dependent upon the storm rainfall that impacts it. Data recorded only from short-duration convective thunderstorms were used to develop the probability models. The storms had recurrence intervals ranging from less than 2 year up to 10 year.

Because the dependent variable in this analysis, debris-flow occurrence, is binomial (i.e., debris flows were produced or not produced), we used a logistic regression approach for analysis. Such analyses have been used in other settings for debris-flow hazard assessments (e.g.,

Pinter and Vestal, 2005; Griffiths et al., 2004). Logistic regression is conceptually similar to multiple regression because relations between one dependent variable and several independent variables are evaluated. Whereas multiple linear regression returns a continuous value for the dependent variable, logistic regression returns the probability of a positive binomial outcome (in this case, debris-flow occurrence) in the form:

$$P = e^x / 1 + e^x, \quad (1)$$

where  $P$  is the probability of debris-flow occurrence, in percent;  $x = \beta_0 + \beta_1 x_1 + \beta_2 x_2 + \dots + \beta_i x_i$ ;  $\beta_i$  are logistic regression coefficients;  $x_i$  are values for the independent variables; and  $i$  is the number of variables (Hosmer and Lemeshow, 2000; Griffiths et al., 2004). In this model, as  $(\beta_0 + \dots + \beta_i x_i)$  increases,  $P$  approaches 1. As  $(\beta_0 + \dots + \beta_i x_i)$  decreases,  $P$  approaches 0. The coefficients ( $\beta_i$ ) are estimated by the method of

maximum likelihood, where coefficients with the highest probability of returning the observed values are selected (Griffiths et al., 2004). Logistic regression does not require normally distributed data because it is based on the log of the odds ratio (the ratio of the odds of an event occurring in one group to the odds of it occurring in another group), in contrast to linear regression, which is based upon ordinary least squares and which requires data transformation to make data distributions symmetrical (Hosmer and Lemeshow, 2000).

A series of univariate, multivariate regression, and multiple logistic regression analyses were used to identify those parameters that best determine debris-flow probability, and to identify statistically significant models (Hosmer and Lemeshow, 2000). Spearman's  $\rho$  (a measure of correlation in nonparametric statistics used when data are in ordinal form) was used to examine univariate correlations between each of the variables (Helsel and Hirsch, 2002). The univariate correlations were then used as an initial indicator of the variables that may be significant in the multivariate logistic regression models. Logistic regression analyses were used to develop multivariate models; all possible combinations of the independent variables were evaluated to determine the combinations that produced statistically robust models. Models were built by sequentially adding variables to the analysis and evaluating the resulting test statistics by comparing partial-likelihood ratios calculated before and after addition of that variable (Helsel and Hirsch, 2002; Nolan and Clark, 1997; Hosmer and Lemeshow, 2000). The difference in partial-likelihood ratios between two sequential models was calculated, and a  $\chi^2$  approximation was calculated with degrees of freedom equal to the number of variables in the new model. The  $p$  values from the  $\chi^2$  distribution were used to determine if the model had been significantly improved by the addition of the new variable. With the addition of each variable, model validity and accuracy were also determined by evaluating the log-likelihood ratio, McFadden's  $\rho^2$ ,  $p$  values calculated for each independent variable, and the percentage of correct responses, or model sensitivity. The log-likelihood ratio measures the success of the model as a whole by comparing observed with predicted values (Hosmer and Lemeshow, 2000; Klienbaum, 1994); specifically, it tests whether the coefficients of the entire model are significantly different from zero. The most significant model is the one with the highest log-likelihood ratio, taking into account the number of independent variables (degrees of freedom) used in the model. The log-likelihood ratio follows a  $\chi^2$  distribution, and the computed  $p$  values indicate

whether model coefficients are significantly different from zero. McFadden's  $\rho^2$  is a transformation of the log-likelihood statistic and is intended to mimic the  $R^2$  (R-square) of linear regression (SPSS, Inc., 2000). The value of  $\rho^2$  is always between zero and one, and a  $\rho^2$  value approaching 1 corresponds to a more significant result. The value of  $\rho^2$  tends to be smaller than  $R^2$ , so a small number does not necessarily imply a poor fit. Values of  $\rho^2$  between 0.20 and 0.40 indicate good results (SPSS, Inc., 2000). As a standard statistical measure, model sensitivity is calculated as the proportion of basins known to have produced debris flows to those predicted by the model to have a probability of occurrence greater than 50% (Hosmer and Lemeshow, 2000). Since it is harder to predict occurrences than nonoccurrences (because there are fewer of them in the database), we looked for models that returned the largest sensitivity.

#### Model Verification

Once all possible statistically significant models were identified, the effectiveness of each model in predicting postfire debris flows was evaluated using an approach described by Chung and Fabbri (2003). The approach is based on the calculation and evaluation of separate success rate and prediction rate curves. Chung and Fabbri (2003) calculated these curves using an analysis of mapped pixels, while here we consider basins as the unit of choice.

Success rate curves were calculated from the data used to derive the models, and they give a relative measure of each model's strength. Success rate curves compare the distributions of the proportion of basins known to have produced debris flows relative to the distributions of calculated probabilities of occurrence, and are simply an expanded measure of model sensitivity (as described above). A 1:1 slope indicates a random distribution, whereas steeper curves located closer to the y-axis indicate the highest success and represent higher probabilities of occurrence calculated for those basins that actually produced debris flows.

Prediction rate curves were used to evaluate the predictive strength of the debris-flow probability models for the Hot Creek fire, which burned in July 2003 in south-central Idaho. In contrast with success rate curves, data used for generation of prediction rate curves are a separate data set from that used to define the models. The burned area was impacted by a storm on 3 August 2003, and it produced debris flows from four of the 16 basins we evaluated. Prediction rate curves show the distributions of proportions of actual debris flow-producing basins relative to the distribution of predicted probabilities. Like the success rate curves, a 1:1 slope

indicates a random distribution, and steeper curves located closer to the y-axis indicate the strongest predictions, which represent higher probabilities of occurrence calculated for basins that actually produced debris flows.

#### Debris-Flow Volume Model

A multiple-regression model (e.g., Draper and Smith, 1981) for estimating volumes of material that can potentially be generated from recently burned basins was developed on the basis of data from debris flows generated from 55 recently burned basins in eight different fires in Utah, Colorado, and California (Gartner et al., 2008) (Fig. 1). Volumes of material eroded from basins were estimated from surveys of a series of closely spaced cross sections, or they were obtained from reports of material volumes collected in debris basins. Volumes ranged from 174 to 864,300 m<sup>3</sup> and were generated from basins between 0.01 and 27.9 km<sup>2</sup> in area.

Different measures of basin gradient and channel network thought to be potential explanatory variables were calculated from either 10 or 30 m DEMs, depending on availability, and they include: average basin gradient, area of basin with slopes greater or equal to 30%, area of basin with slopes greater or equal to 50%, relief ratio, basin ruggedness, drainage density (the total length of streams in a basin divided by the square root of the basin area; Horton, 1932), and bifurcation ratio (the ratio of streams of any order to the number of streams of the next highest order; Horton, 1932).

The same measures of grain-size distribution and soils properties as described for the debris-flow probability models were also evaluated as potential explanatory variables. However, in contrast with the variables evaluated in the probability models, the measures of basin gradient and burn severity were quantified directly as areas, rather than as percentages of areas.

Rainfall data used in the development of the volume model were recorded from both long-duration frontal storms and short-duration convective thunderstorms. As with the storms used to develop the probability model, these storms had recurrence intervals ranging from less than 2 years up to 10 years.

Multiple linear regression analysis (e.g., Draper and Smith, 1981) was used to determine the factors that most strongly affect the volume of debris-flow material deposited at a basin outlet, and to build a model to predict debris-flow volume in response to a given storm. As a first step, histograms of all variables were examined to determine whether data were normally distributed. Square-root and natural-log transforms were applied to skewed data, and a correlation

analysis was used to determine which of the independent variables were most strongly related to debris-flow volume. The independent variable with the strongest correlation to debris-flow volume was then used to create an initial regression model. ANOVA and Student *t*-tests were used to indicate whether 95% confidence in the coefficient of the variable existed. Independent variables were added sequentially to the regression model and retained if the  $R^2$  value improved by more than 0.05 and the regression coefficient was significant at the 95% level, as determined by *F*- and *t*-statistics. A variable was discarded if its addition caused the model significance to fall below the 95% confidence level. A multiple regression model with all significant explanatory variables included was tested to ensure that assumptions of linearity, constant variance, and normally distributed residuals (Helsel and Hirsch, 2002) were met. Finally, a bias correction that accounted for the transformation from log units of the predicted variable (volume) was calculated using the procedure described in Helsel and Hirsch (2002). Without this, when log *V* is transformed to *V*, the value obtained represents a median value. On a log scale, the median can be much less than the mean, particularly for larger values. The bias correction changes the estimate of the median value to an estimate of the mean value.

#### Model Verification

The model was verified by comparing predicted volumes with actual volumes from a data set of 21 postfire debris-flow events reported in the literature and not used in the development of the model (Gartner et al., 2008). The 95% prediction interval (or two standard errors of the predicted value) of a one-to-one correspondence line of predicted values against actual values was used to evaluate how well the model predicted independent data (data not used to generate the model). The one-to-one correspondence line, rather than a regression line, was evaluated because of the multidimensionality of a multiple regression model with more than one independent variable. If the majority of the actual volumes are within the 95% prediction interval of the volume determined by the model, then the model is considered to be verified.

## RESULTS

### Debris-Flow Probability Models

Examinations of univariate correlations between each of the independent variables and the presence or absence of debris flows, as characterized by the absolute value of Spearman's  $\rho$ , indicate that the following variables are most

strongly correlated with the presence of debris flows (Table 2): relief ratio, basin ruggedness, the percentage of the basin burned, and the percentage of the basin burned at a combination of high and moderate severities, the sorting of the burned soil grain-size distribution, and the available water capacity, percent clay, soil thickness, and soil permeability.

The logistic regression analyses identified five statistically significant multivariate models that incorporate the variables strongly correlated with debris-flow occurrence (Table 2). Measures of model sensitivity for each of these models (Table 2) show that more than 40% of basins known to have produced debris flows have a calculated probability of occurrence of at least 50%. Values for McFadden's  $\rho^2$  are between 0.26 and 0.35 for each of these models

(values of  $\rho^2$  between 0.20 and 0.40 are considered to indicate good results; SPSS, Inc., 2000). These values, coupled with the additional tests of model quality during the model-building process, indicate that each one of the five models is statistically valid.

Of the five statistically significant models, each showed a different combination of variables most strongly correlated with debris-flow occurrence (Table 2). The percentage of the basin burned at a combination of high and moderate severities and the average storm intensity were significant in every model. Of the different measures of basin gradient, the percentage of the area with slopes greater than or equal to 30% and ruggedness were significant variables, appearing either in combination or separately. Soil properties, including the percent clay, the

percent organic matter, the hydrologic group, the liquid limit, and the sorting of the burned soil grain-size distribution, either in combination or separately, were identified as significant by the five models. These variables, acting in combination, best separated basins that produced debris flows from those that did not produce debris flows. The other potential explanatory variables (measures of gradient, aspect, burned extent, soil properties, and rainfall) were not significant variables in the logistic regression models. Note that each of these models produces somewhat different results.

#### Model Verification

Success rate curves were used to evaluate the relative strength of each of the five models (Fig. 3) (Chung and Fabbri, 2003). These curves

TABLE 2. SUMMARY OF UNIVARIATE SPEARMAN'S  $\rho$  CORRELATIONS AND MULTIVARIATE LOGISTIC REGRESSION ANALYSES

	Spearman's $\rho$ from univariate correlations	Model A	Model B	Model C	Model D	Model E
Sensitivity		44%	40%	41%	41%	40%
McFadden's $\rho^2$		0.35	0.31	0.30	0.27	0.26
Logistic regression constant		-0.7 (0.797)	-7.6 (0.000)	4.8 (0.132)	-0.3 (0.865)	-0.6 (0.707)
Topographic variables						
Average gradient	0.22	—	—	—	—	—
Percentage of basin area with gradients $\geq 30\%$	0.37	0.03 (0.035)	—	—	—	—
Percentage of basin area with gradients $\geq 50\%$	0.11	—	—	—	—	—
Ruggedness	0.49	-1.6 (0.000)	-1.10 (0.002)	—	—	—
Relief ratio	0.49	—	—	—	—	—
Aspect	0.19	—	—	—	—	—
Burn severity variables						
Percentage of basin area burned at low severity	-0.32	—	—	—	—	—
Percentage of basin area burned at moderate severity	0.32	—	—	—	—	—
Percentage of basin area burned at high severity	0.09	—	—	—	—	—
Percentage of basin area burned at moderate and high severity (percent)	0.54	0.06 (0.000)	0.06 (0.000)	0.05 (0.000)	0.04 (0.000)	0.04 (0.000)
Percentage of basin area burned at high, moderate and low severities	0.50	—	—	—	—	—
Soil property variables						
Grain-size distribution median	0.32	—	—	—	—	—
Grain-size distribution mean	-0.06	—	—	—	—	—
Grain-size distribution sorting	0.50	—	—	—	1.9 (0.000)	1.9 (0.000)
Grain-size distribution skewness	0.35	—	—	—	—	—
Clay content (percent)	0.53	0.2 (0.001)	0.09 (0.017)	0.2 (0.001)	—	—
Available water capacity	0.53	—	—	—	—	—
Permeability	-0.44	—	—	—	—	—
Erodibility	0.34	—	—	—	—	—
Organic matter (percent)	-0.27	—	-1.4 (0.025)	—	-1.0 (0.087)	—
Soil thickness	0.51	—	—	—	—	—
Liquid limit (percent)	0.38	-0.4 (0.001)	—	-0.4 (0.001)	—	—
Hydrologic group	-0.15	—	—	-1.5 (0.000)	—	—
Hydric capacity	0.14	—	—	—	—	—
Storm rainfall variables						
Total storm rainfall	0.25	—	—	—	—	—
Storm duration	0.06	—	—	—	—	—
Average storm intensity (mm/h)	-0.01	0.07 (0.004)	0.06 (0.002)	0.07 (0.004)	0.06 (0.000)	0.05 (0.000)
Maximum 10 min rainfall intensity	-0.12	—	—	—	—	—
Maximum 15 min rainfall intensity	-0.43	—	—	—	—	—
Maximum 30 min rainfall intensity	-0.13	—	—	—	—	—
Maximum 60 min rainfall intensity	0.28	—	—	—	—	—

Note: Sensitivity is the percentage of basins that produced debris flows with a calculated probability greater than 50%; McFadden's  $\rho^2$  is a relative measure of the strength of each logistic regression model; values not enclosed in parentheses are logistic regression coefficients; values enclosed in parentheses are individual  $p$  values; — indicates no observed relation. Units are given for those independent variables found to affect debris-flow occurrence and are not dimensionless.

indicate that models A, B, and C (defined in Table 2) result in the highest proportion of actual debris flow-producing basins being characterized by the highest calculated probabilities; hence, they are the strongest models. The other models also deviate sufficiently from the 1:1 line to assume that they also adequately characterize the probability of postfire debris-flow occurrence. The fact that all five models are adequate and yet each produces somewhat different results suggests that different models might be more effective in predicting the probability of postfire debris flows in different settings.

**Debris-Flow Volume Model**

A plausible mean volume of material ( $V$ , in  $m^3$ ) deposited by a debris flow at the outlet of a recently burned basin in the Intermountain West can be estimated from the multivariate regression model:

$$\ln V = 7.2 + 0.6(\ln A) + 0.7(B)^{1/2} + 0.2(T)^{1/2} + 0.3, \quad (2)$$

where  $A$  (in  $km^2$ ) is the area of the basin having slopes greater than or equal to 30%,  $B$  (in  $km^2$ ) is the area of the basin burned at high and moderate severity,  $T$  (in mm) is the total storm rainfall, and 0.3 is a bias correction that changes the predicted estimate from a median to a mean value (Helsel and Hirsch, 2002). The  $R^2$  value and standard error of the residuals for this model are 0.83 and 0.90, respectively. Additional explanatory variables of gradient, burned extent, and rainfall produced less satisfactory models.

**Model Verification**

The model for debris-flow volume was verified using data from 21 basins not used in the generation of the model by comparing predicted values with reported values (Gartner et al., 2008). Eighty-seven percent of the actual volumes were within the 95% prediction interval, or within two standard errors of the predicted values on a one-to-one correspondence line. All of the reported volumes were within one order of magnitude of the volumes predicted by the model (Fig. 4).

**HAZARD ASSESSMENT OF BASINS BURNED BY HOT CREEK FIRE, IDAHO**

Using data from the 2003 Hot Creek fire in central Idaho as an example, we illustrate how the debris-flow probability and volume models can be applied in a GIS framework to assess postfire debris-flow hazards for given storm conditions. The Hot Creek fire burned 120  $km^2$  of a subalpine fir ecosystem in steep

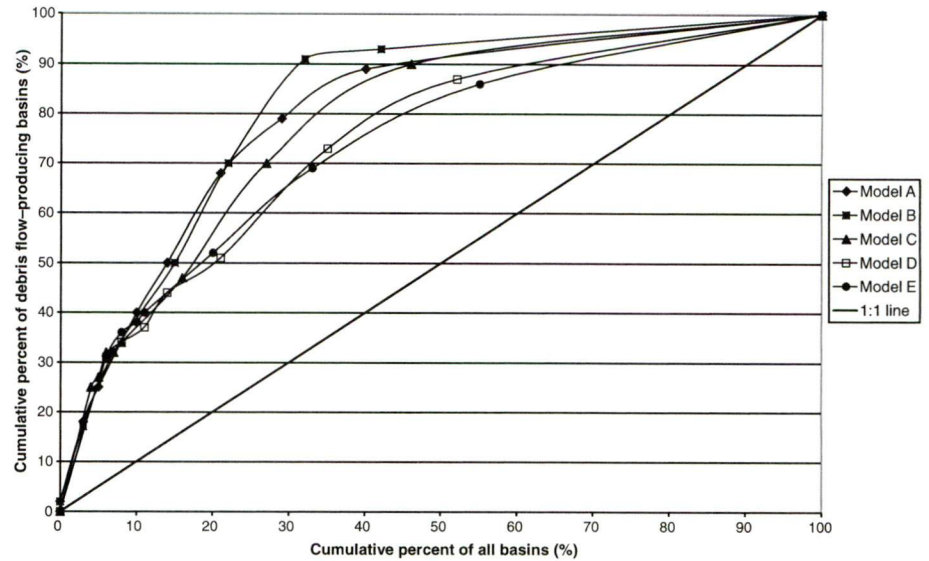

**Figure 3.** Success rate curves calculated using the method of Chung and Fabbri (2003) for each of the five logistic multiple regression models. The 1:1 line indicates a random distribution. The steepest curves located closest to the y-axis indicate the highest success and represent higher probabilities of occurrence calculated for those basins that actually produced debris flows.

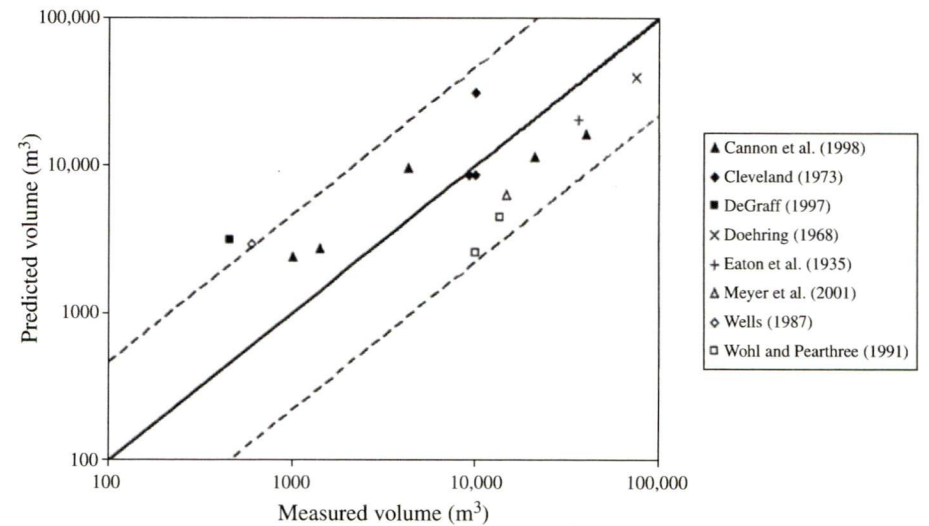

**Figure 4.** Comparison of debris-flow volume estimates reported in the literature to model predictions. The solid line indicates an exact fit, and the dashed lines represent the 95% prediction interval or two standard errors of the predicted values.

(40%–75% gradients) mountainous terrain in the upper Middle Fork Boise River drainage, approximately 3 km west of the historical backcountry mining community of Atlanta, Idaho. The burned basins are strongly dissected by first- and second-order channels (Figs. 5A and 5B), and the elevation ranges from 1500 m along the Middle Fork Boise River corridor to nearly 2800 m in the vicinity of Steel Mountain. Sixty-two percent, or 80  $km^2$ , of the area

was burned at moderate and high severities (Fig. 5A). The area is underlain by the Late Cretaceous granitic Idaho Batholith. Granodiorite, quartz monzonite, and quartz diorite have weathered to form well-drained, non-cohesive soils with little horizon development and moderate to low fertility (Boise National Forest, 2003, written commun.). Cool, moist, moderately deep sandy loam soils occupy north and east aspects and support forest vegetation.



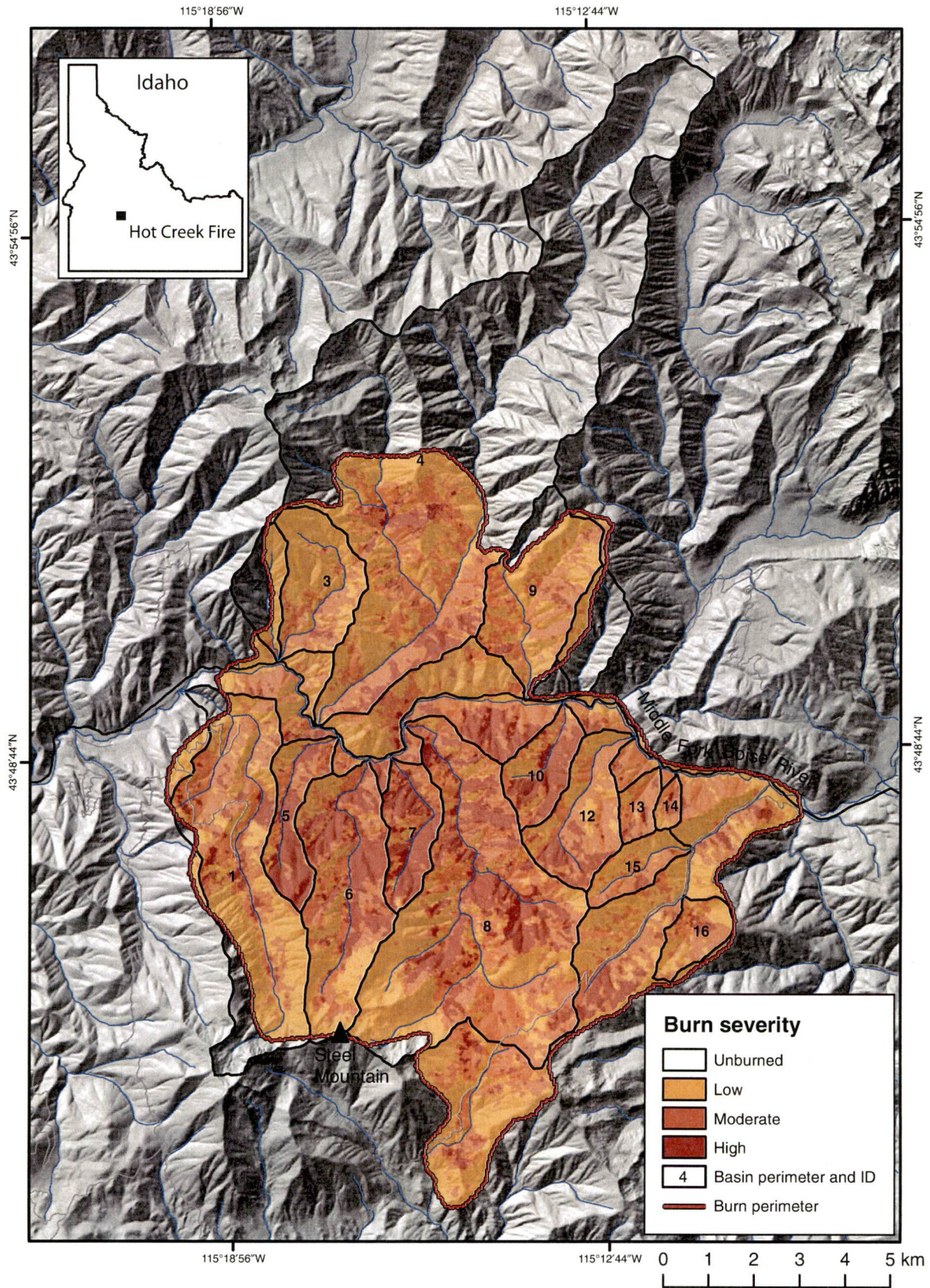

Figure 5 (on this and following page). (A) Shaded relief image of area burned by the Hot Creek fire showing burn severity and basins evaluated. Burn severity map is from Boise National Forest (Boise National Forest, 2003, written commun.).

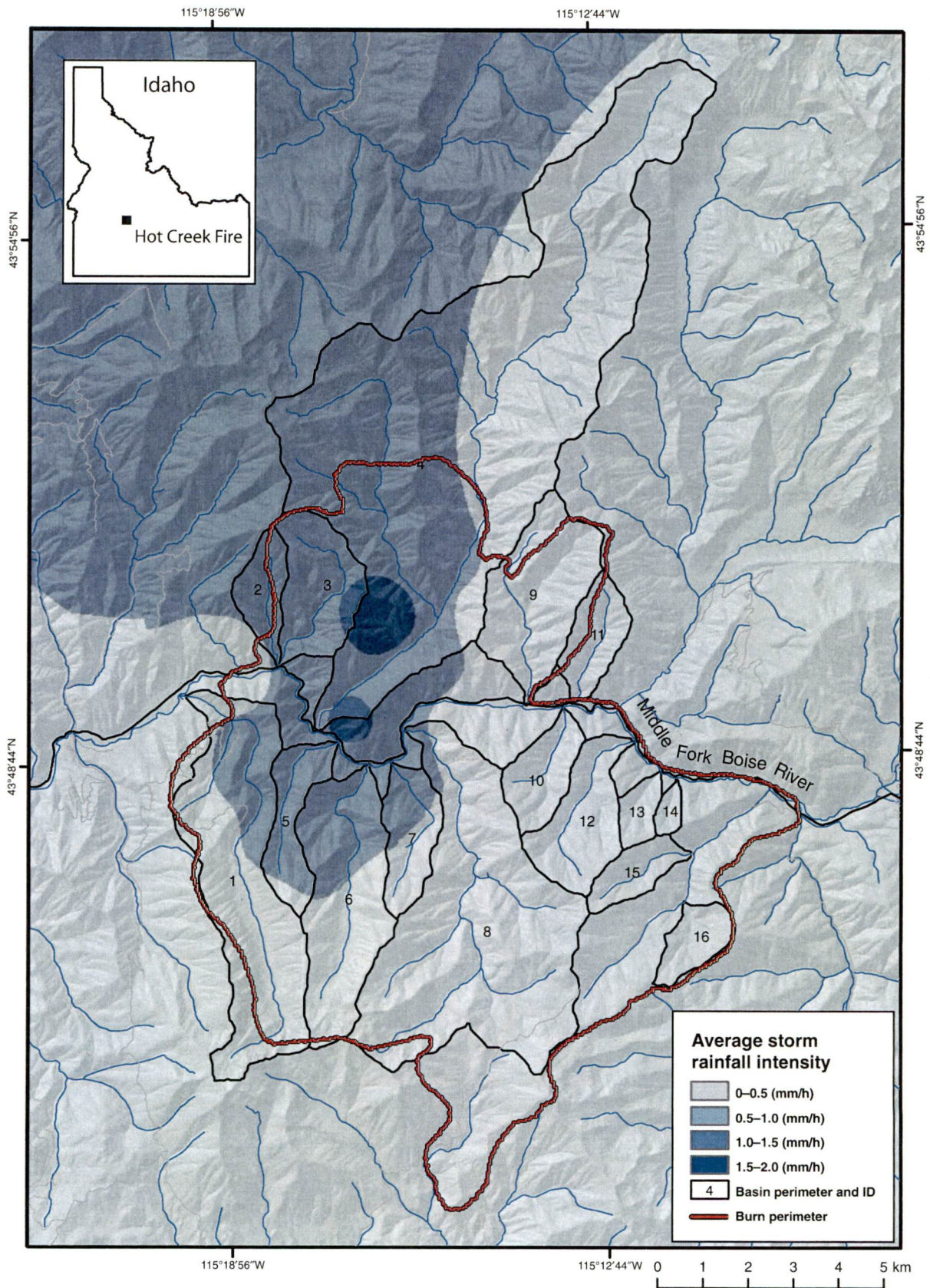

Figure 5 (continued). (B) Average rainfall intensity of 3 August 2003 storm over Hot Creek fire. Storm data from radar imagery were provided by Jay Briedenbach, National Weather Service (2003).

Granular, coarse sandy soils are found on south-facing slopes, which are mostly dry and sparsely vegetated. Deposits of glacially derived materials mantle some hillslopes.

For the Hot Creek assessment, 16 burned basins were delineated using a 10 m DEM and GIS hydrological tools. The outlets of basins to be evaluated were located at breaks in slope between mountain fronts and valleys, or at the location of an expected general transition between erosion and deposition (Figs. 5A and 5B). Basin outlets were positioned such that the sizes of basins evaluated ranged between 0.01 km<sup>2</sup> and 30 km<sup>2</sup>, comparable to the basin sizes used in the development of the volume-estimation regression model. If necessary, basins larger than 30 km<sup>2</sup> can be subdivided into tributaries to the main channel. Basin outlets can also be located at road crossings if culvert capacities are in question, above reservoirs where sediment input is a concern, or above identified cultural features at risk. For example, in this assessment, concern about debris-flow impact to culverts in the dirt road that travels up the unnamed, easternmost burned basin prompted location of basin outlets at road crossings, rather than at the junction with the Middle Fork Boise River. It is also not necessary to evaluate every basin within the burned area. For example, the basin that drains off Steel Mountain to the south, although burned, showed no potential downstream impact, and so is not included in this analysis. Areas that are not well-defined basins, like those between basins 4 and 9, and between basins 8 and 10 along the Middle Fork Boise River, are also not included.

Once basins of interest were identified, basin outlets were positioned on a detailed stream network with the visual aid of a shaded-relief image. The watershed boundaries were automatically generated from the basin outlets using GIS hydrological tools.

### Debris-Flow Probability Calculation and Map

The probability of debris-flow occurrence was calculated for each of the 16 basins using probability model A as an example, where

$$P(\text{the probability of debris-flow occurrence}) = e^{x/(1 + e^x)},$$

and

$$x = -0.7 + 0.03(\%A) - 1.6(R) + 0.06(\%B) + 0.07(I) + 0.2(C) - 0.4(LL),$$

where %A is the percentage of the basin area with gradients greater than or equal to 30%, R is basin ruggedness, %B is the percentage of the basin area burned at high and moderate

severity, I is average storm rainfall intensity (in mm/h), C is clay content (in %), and LL is the liquid limit. Table 2 provides the constants and coefficients for this model, as well as for an additional four models.

For each basin, values for each of the input variables for the model were determined. Table 3 shows measured parameters used in the assessment of debris-flow probability for the Hot Creek fire area. Basin area and measures of gradients were obtained using spatial analyst tools with 10 m DEMs, the basin areas burned at different severities were characterized from the watershed response map developed by the Burned Area Emergency Response (BAER) Team (Boise National Forest, 2003) (Fig. 5A), and soil parameters were obtained from the STATSGO database (Schwartz and Alexander, 1995). If more than one value for any independent variable was present in a basin, a single, spatially weighted mean value for that parameter was calculated by multiplying each value by the percentage of the basin area in which that value occurred and summing each of these products.

For this illustration, rainfall input into the model was a radar-derived rainfall distribution of an actual storm that impacted the area on 3 August 2003 (Fig. 5B). However, rainfall input into the model can be either as a single average intensity of a storm of interest, of a set of storms, or as a distributed storm across the burned area. Cannon and Gartner (2005) found that in the Intermountain West, the great majority of debris-flow events occur in response to low-recurrence (<2–10 years), low-duration (<1 h) convective thunderstorms. We recommend evaluating storms, or sets of storms, of similar recurrence and durations when using this approach (e.g., Cannon et al., 2003b).

A design rainfall must be included in the analysis. Because the models presented here do not have zero intercepts, it would be possible to calculate probability of debris flow and some volume even without rain. However, rainfall is the driver of the response, and so must be included.

After values of debris-flow probability are calculated for each basin, they are proportioned into classes and assigned a relative ranking to be presented in map form (Table 3; Fig. 6A). In this case, we divided the probabilities into four classes: 0%–25%; 26%–50%; 51%–75%; and 76%–100%. For the Hot Creek setting, the probability model identifies nine basins as having a greater than 75% probability of debris-flow occurrence, five as having between 51% and 75% probability, none with a probability between 26% and 50%, and two with less than a 25% chance of producing debris flows. For illustra-

tion purposes, the probability ranking is shown as a function of the entire basin, even if only a portion of the basin is burned. Note that every burned basin has some probability of generating debris flows. It may be low, but there is still a chance. This fact points to the necessity of addressing the additional question of the potential volume of debris flows.

### Debris-Flow Volume Calculation and Map

We used Equation 2 to calculate potential debris-flow volumes. Input variables consist of the area of the basin with gradients greater than or equal to 30%, area burned at high and moderate severity, and the total storm rainfall (Table 4). Measures of basin gradients were again obtained using spatial analyst tools with 10 m DEMs, and the basin areas burned at different severities were characterized from the watershed response map developed by the BAER Team (Fig. 5A). As in the probability assessment, we used a radar-derived rainfall distribution of an actual storm that impacted the area on 3 August 2003 (Fig. 5B).

As in the case of the probability calculation, values of debris-flow volume calculated for each basin were proportioned into classes and assigned a relative ranking to be presented in map form (Table 4; Fig. 6B). In this example, and because in our verification we found that all of the reported volumes were within one order of magnitude of the volumes predicted by the model, we divided the volumes into four order of magnitude classes: 0–1000 m<sup>3</sup>; 1001–10,000 m<sup>3</sup>; 10,001–100,000 m<sup>3</sup>; and greater than 100,000 m<sup>3</sup>.

For the Hot Creek fire, the volume model identified one basin as capable of producing close to 1000 m<sup>3</sup> of material, five basins that could produce between 1001 and 10,000 m<sup>3</sup> of material, eight basins that could generate between 10,001 and 100,000 m<sup>3</sup> of material, and two basins that could potentially generate more than 100,000 m<sup>3</sup> of material in response to the 3 August 2003 storm. For illustration purposes, the calculated volume ranking is shown as a function of an entire basin, even if only a portion of a basin is burned.

### Combined Relative Hazard Map

Debris-flow hazards from a given basin can be considered as the combination of both probability and volume. For example, in a given setting, the most hazardous basins will show both a high probability of occurrence and a large estimated volume of material. Slightly less hazardous would be basins that show a combination of either relatively low probabilities and

TABLE 3. DATA FROM BASINS BURNED BY THE HOT CREEK FIRE USED TO CALCULATE THE PROBABILITY OF POSTFIRE DEBRIS FLOWS, THE CALCULATED PROBABILITY, AND THE PROBABILITY CLASS RANKING USED TO GENERATE MAP OF DEBRIS-FLOW PROBABILITIES (FIG. 6A)

Basin name	Basin ID	Percentage of basin area with		Basin ruggedness (f)	Percentage of basin area		Average storm rainfall intensity (i, mm/h)	Soil clay content (C, %)	Soil liquid limit (LL, %)	Calculated probability (P, %) <sup>1</sup>	Probability class ranking <sup>2</sup>
		gradients greater than or equal to 30% (%A)	burned at high and moderate severity (%B)								
Hot Creek	1	89.4	41.0	0.41	10.7	9.2	13.25	67	3		
Unnamed	2	98.4	2.7	0.76	19.6	9.2	13.25	24	1		
Steppe Creek	3	98.1	31.2	0.52	25.1	9.2	13.25	75	3		
Black Warrior Creek	4	91.8	15.1	0.18	17.2	9.2	13.25	52	3		
Steel Creek*	5	94.6	86.4	0.64	21.3	9.2	13.25	98	4		
Lake Creek*	6	92.0	67.2	0.42	13.0	9.2	13.25	92	4		
Bear Creek*	7	97.1	92.9	0.61	14.6	9.2	13.25	98	4		
Bald Mtn Creek*	8	89.3	63.3	0.27	4.9	9.2	13.25	86	4		
Eagle Creek	9	94.7	38.1	0.35	6.9	9.2	13.25	64	3		
Burnt Log Creek	10	94.7	79.4	0.48	5.7	9.2	13.25	93	4		
Snyder Creek	11	97.1	1.9	0.53	7.9	9.2	13.25	16	1		
Fall Creek	12	92.9	72.2	0.47	2.5	9.2	13.25	88	4		
Unnamed	13	96.7	86.1	0.77	3.7	9.2	13.25	92	4		
Unnamed	14	98.8	78.7	0.95	4.8	9.2	13.25	87	4		
West James Creek	15	90.8	49.7	0.55	3.7	9.2	13.25	65	3		
East James Creek	16	84.7	56.6	0.36	5.2	9.2	13.25	77	4		

\*Debris-flow-producing basin in response to 3 August 2003 storm.

<sup>1</sup>Probability calculated using model A.

<sup>2</sup>Based on four class divisions: 1—0% to 25%, 2—26% to 50%, 3—51% to 75%, and 4—76% to 100%.

larger volume estimates or high probabilities and smaller volume estimates. The lowest relative hazard would be for basins that show both low probabilities and the smallest volumes. We thus suggest the possibility of combining the two maps to produce a single map of relative hazard ranking. By assigning rankings between 1 and 4 (with 4 being the highest) to both the probability and volume classes, adding the class ranks together, and then proportioning this value into classes, a single combined relative hazard ranking can be obtained for each basin (Table 5). A final map showing the combined relative hazard can then be generated (Fig. 6C). This map shows the spectrum of predicted basin response, from those basins with the lowest probability of producing the smallest events (basins 2 and 11) to those basins with the highest probability of producing the largest events (basins 4, 5, 6, 7, 8, 10, and 12). For illustration purposes, the combined relative ranking is shown as a function of an entire basin, even if only a portion of a basin is burned.

Application of the probability and volume models and calculation of the combined relative hazard ranking do not provide information on potential areas that can be impacted by debris flows as they travel downstream from the evaluated basins. However, we have found that it is often necessary to indicate, in a general sense, downstream reaches that can potentially be impacted by debris flows, as shown in Figures 6A, 6B, and 6C, to adequately convey the potential hazards on maps generated using this approach.

### PREDICTIVE STRENGTH OF PROBABILITY, VOLUME, AND COMBINED MODELS IN CENTRAL IDAHO

On 3 August 2003, a thunderstorm impacted basins that had been burned by the Hot Creek fire in July 2003. The resultant basin response provided the opportunity to qualitatively evaluate the predictive strength of the five debris-flow probability models, the debris-flow volume model, and the combined mapping approach in this setting. The hour-long storm focused over the burned area, and radar estimates of precipitation intensity ranged between 2 and 45 mm/h (Fig. 5B; Table 4). Of the 16 basins burned by the Hot Creek fire and evaluated in this study, four produced debris flows in response to this storm: Steel Creek, Lake Creek, Bear Creek, and Bald Mountain Creek; the remaining basins showed evidence of sediment-laden floods (Tables 3, 4, and 5). The lack of discrete landslide scars at the heads of the debris-flow paths suggests that the flows were generated through progressive bulking of runoff with material eroded from hillslopes and from channel incision (Fig. 7).

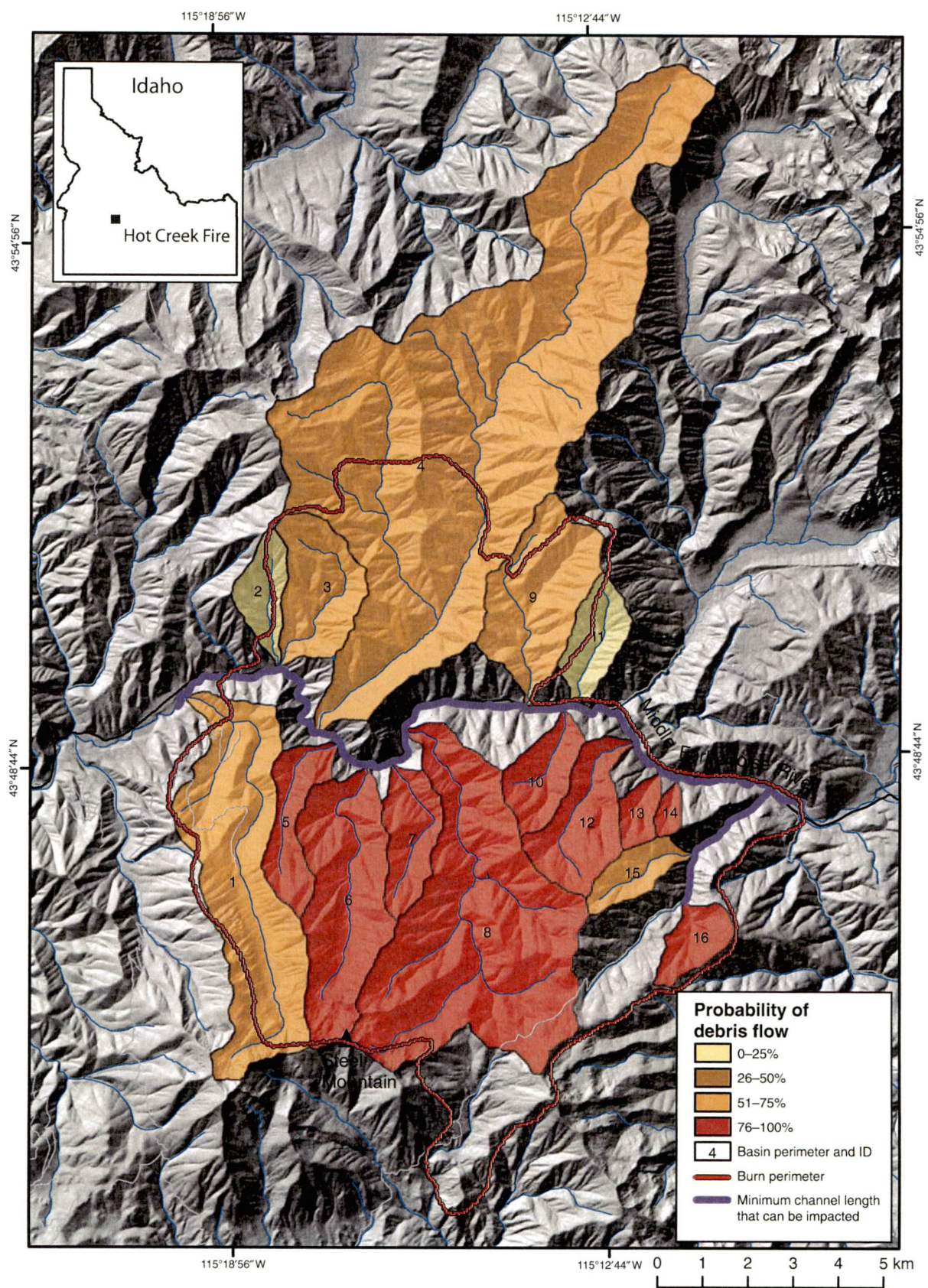

Figure 6 (on this and following two pages). (A) Map of probability of debris-flow occurrence for basins burned by the Hot Creek fire in response to the 3 August 2003 storm (cf. Table 3).

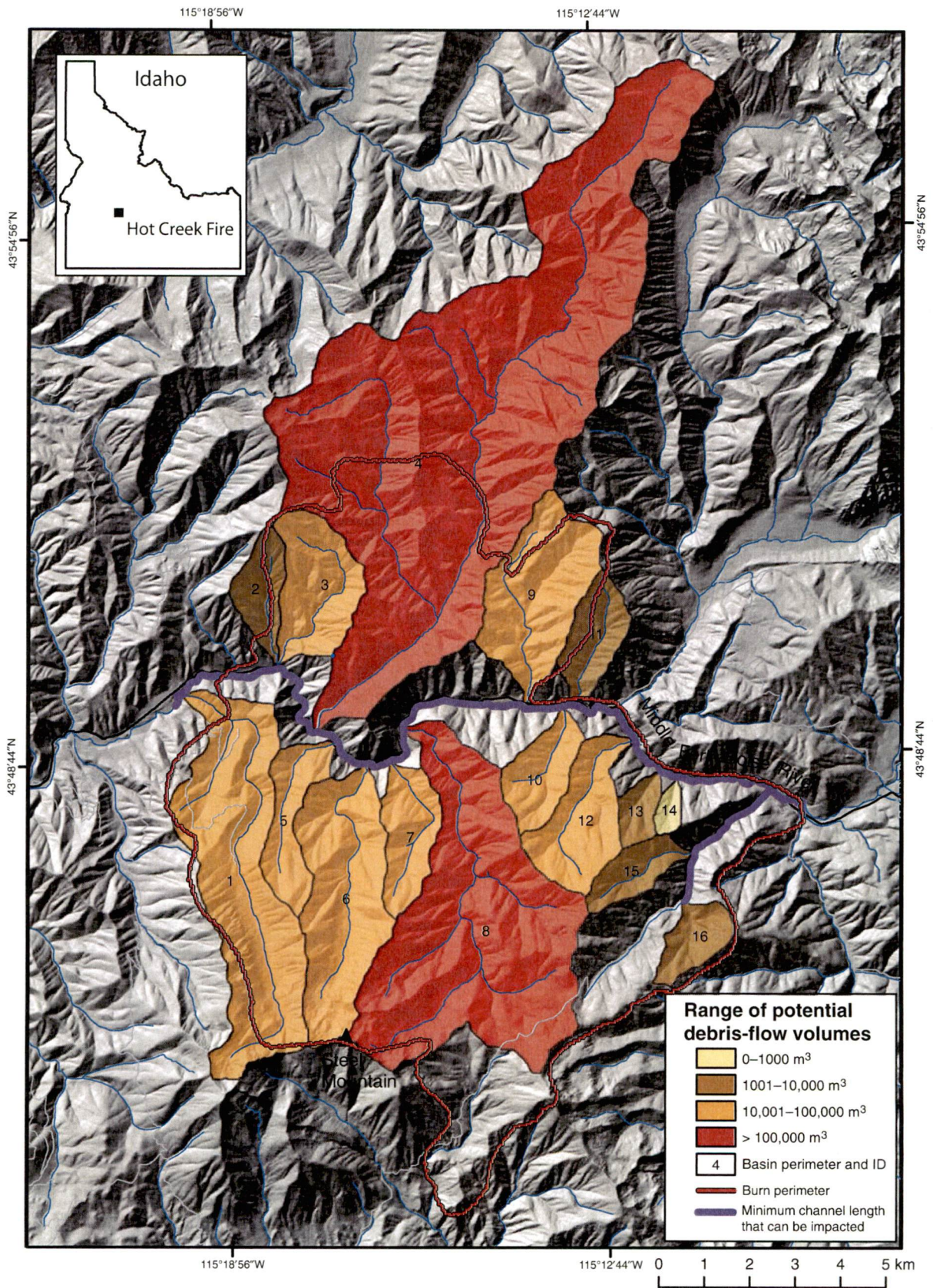

Figure 6 (continued). (B) Map of estimated debris-flow volumes from basins burned by the Hot Creek fire in response to the 3 August 2003 storm (cf. Table 4).

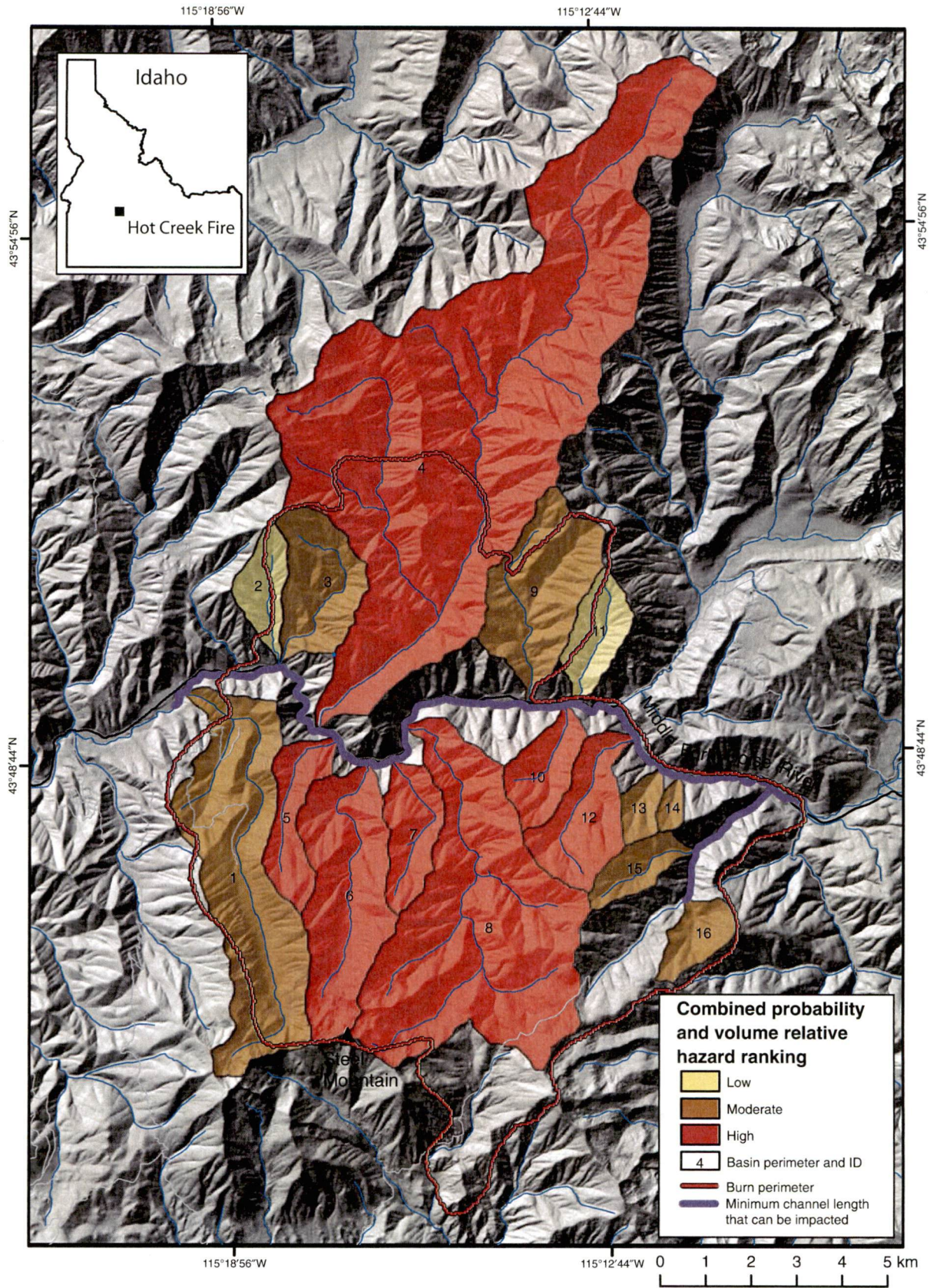

Figure 6 (continued). (C) Relative postfire debris-flow hazard map for Hot Creek fire in response to the 3 August 2003 storm. Map was generated by combining probability and volume class rankings (cf. Table 5).

TABLE 4. DATA FROM BASINS BURNED BY THE HOT CREEK FIRE USED TO CALCULATE THE VOLUME OF POSTFIRE DEBRIS FLOWS, THE CALCULATED VOLUME, AND THE VOLUME CLASS RANKING USED TO GENERATE MAP OF POTENTIAL DEBRIS FLOW VOLUMES (FIG. 6B)

Basin name	Basin ID	Area of basin with gradients greater than or equal to 30% (A, km <sup>2</sup> )	Area of basin burned at high and moderate severity (B, km <sup>2</sup> )	Total storm rainfall (T, mm)	Calculated volume (V, m <sup>3</sup> )	Volume class ranking <sup>†</sup>
Hot Creek	1	12.9	5.9	10.7	88,000	3
Unnamed	2	2.1	0.1	19.6	8500	2
Steppe Creek	3	4.7	1.5	25.1	29,000	3
Black Warrior Creek	4	48.3	7.9	17.2	304,000	4
Steel Creek*	5	2.9	2.7	21.3	27,000	3
Lake Creek*	6	8.5	6.2	13.0	77,000	3
Bear Creek*	7	3.1	3.0	14.6	26,000	3
Bald Mtn Creek*	8	19.6	13.9	4.9	228,000	4
Eagle Creek	9	6.7	2.7	6.9	30,000	3
Burnt Log Creek	10	2.6	2.2	5.7	15,000	3
Snyder Creek	11	2.5	0.0	7.9	5500	2
Fall Creek	12	4.2	3.3	2.5	21,000	3
Unnamed	13	1.1	1.0	3.7	5700	2
Unnamed	14	0.5	0.4	4.8	2900	1
West James Creek	15	1.7	0.9	3.7	7100	2
East James Creek	16	1.6	1.1	5.2	7900	2

\*Debris-flow-producing basin in response to 3 August 2003 storm.

<sup>†</sup>Based on four class divisions: 1—1 to 1000 m<sup>3</sup>; 2—1001 to 10,000 m<sup>3</sup>; 3—10,001 to 100,000 m<sup>3</sup>; 4—>100,000 m<sup>3</sup>.

Debris fans were deposited in the Middle Fork Boise River and, in some cases, either dammed the river completely or pushed it against its north bank (Fig. 8). The road to Atlanta along the Middle Fork Boise River was destroyed by these events.

Prediction rate curves (Fig. 9) indicate that models A, B, and C produced the highest proportion of basins that actually produced debris flows. These models best assessed postfire debris-flow susceptibility in this part of the Intermountain West. Models D and E were less satisfactory in this setting, in that debris flows were produced from basins for which low potential probabilities were calculated.

Unfortunately, comparable information for evaluating the predictive strength of the volume model in this setting is not available. However, field estimates of debris flows depositing 10,000–20,000 m<sup>3</sup> of material in the Middle Fork Boise River at the Lake Creek tributary (Boise National Forest, 2004) compare roughly with a model estimate of 48,000 m<sup>3</sup>, and a field estimate of 80,000–100,000 m<sup>3</sup> of cumulative material deposited by debris flows from Lake, Steele, and Bear Creeks (Boise National Forest, 2004, written commun.) compares well with a model prediction of 77,000 m<sup>3</sup>. Both estimates are within the 95% confidence interval estimate of the model shown in Figure 4.

The map of combined relative hazard (Fig. 6C) shows six basins for which the highest probabilities of producing the largest events were predicted. Four of these basins did indeed produce debris flows of significant size, indicating that the approach may produce a conservative result that would err on the side of caution. The two basins identified as presenting high relative hazards but that did not produce debris

flows are the smallest and the largest of the sample, perhaps illustrating the pitfalls of linear statistical analyses.

**USES AND LIMITATIONS OF APPROACH**

The approach described here for assessing debris-flow hazards provides estimates of the probability of debris-flow occurrence and potential debris-flow volumes that can issue from outlets of burned basins over extensive areas in the Intermountain West in response to short-duration (<1 h), low-recurrence-interval (<2–10 years) convective thunderstorms. Application of the predictive models before the occurrence of wildfires using a projected burn severity distribution and a specified, or design, storm

can help identify sensitive drainage basins that could benefit from management efforts to prevent catastrophic burning. Application of these models using conditions of a specified storm, or set of storms, immediately following a fire will provide information necessary to make effective and appropriate mitigation and planning decisions, and will guide decisions for evacuation, shelter, and escape routes in the event of forecasts of storms of similar magnitude to those evaluated. The models described here can also potentially be linked with real-time precipitation forecasts and measurements to generate dynamic maps of potential postfire debris-flow hazards as storm conditions develop. We suggest the use of these empirical tools until a better understanding of the physical processes that generate debris flows can be developed.

TABLE 5. COMBINED PROBABILITY AND VOLUME CLASS RANKINGS FOR BASINS BURNED BY THE HOT CREEK FIRE USED TO GENERATE RELATIVE HAZARD MAP (FIG. 6C)

Basin name	Basin ID	Probability class ranking	Volume class ranking	Combined hazard ranking (probability class + volume class)	Combined relative hazard ranking <sup>†</sup>
Hot Creek	1	3	3	6	Moderate
Unnamed	2	1	2	3	Low
Steppe Creek	3	3	3	6	Moderate
Black Warrior Creek	4	3	4	7	High
Steel Creek*	5	4	3	7	High
Lake Creek*	6	4	3	7	High
Bear Creek*	7	4	3	7	High
Bald Mtn Creek*	8	4	4	8	High
Eagle Creek	9	3	3	6	Moderate
Burnt Log Creek	10	4	3	7	High
Snyder Creek	11	1	2	3	Low
Fall Creek	12	4	3	7	High
Unnamed	13	4	2	6	Moderate
Unnamed	14	4	1	5	Moderate
West James Creek	15	3	2	5	Moderate
East James Creek	16	4	2	6	Moderate

\*Debris-flow-producing basin in response to 3 August 2003 storm.

<sup>†</sup>Based on three class divisions: 1 to 3—low; 4 to 6—moderate; 7 to 9—high.





**Figure 7. Channel incision from passage of debris flow in Lake Creek tributary to the Middle Fork Boise River. Photograph by Dave Hilgendorf, U.S. Department of Transportation Federal Highway Administration.**

The potential for debris-flow activity decreases with time and the concurrent revegetation and stabilization of hillslopes. A compilation of information on postfire runoff events reported in the literature from throughout the intermountain western United States indicates that most debris-flow activity occurs within about 2 years following a fire (Gartner et al., 2004). We thus conservatively expect that maps generated using this approach may be applicable for approximately 3 years after fires for the storm conditions considered.

Over longer time frames (years to decades after a fire), decay of tree-root systems may reduce the shear strength of hillslope materials and, along with reduced evapotranspiration, can result in the generation of shallow landslides that mobilize into debris flows (Meyer, 2002; Swanson, 1981; Ziemer, 1981). This assessment method does not address these processes.

The assessments presented here are specific to postfire debris flows; significant hazards from flash flooding can remain for many years after a fire and will require separate assessments. Furthermore, this approach does not provide science-based information on potential areas that can be inundated by fire-related debris flows. It may be necessary to indicate the areas that can potentially be impacted by debris flows on maps generated using this approach to adequately convey the potential hazards. Because the data used

to generate the probability model come exclusively from the Intermountain West, application of the probability model (and thus the combined relative hazard assessment technique) is not appropriate in other climatologic and geographic settings. However, similar region-specific models (for example, Southern California) can be developed, given appropriate data.

### SUMMARY AND CONCLUSIONS

In this paper, we identified those factors that most strongly control the debris-flow response of burned basins in the Intermountain West to short-duration, low-recurrence-interval convective thunderstorms, and we developed integrated, multivariate statistical models that can be used to estimate the probability and volume of potential debris flows. The models are functions of combinations of different measures of burn severity, basin morphology, material properties, and storm rainfall. A combination of the probability and volume assessments can be used to identify a relative hazard ranking of recently burned basins.

Logistic multivariate regression analyses indicated that the percentage of basin burned at a combination of high and moderate severities and the average storm rainfall intensity were strongly correlated with the debris-flow response. Of the different measures of basin

gradient evaluated, the percentage of basin area with slopes greater than or equal to 30% and basin ruggedness were significant variables, either in combination or separately. Soil properties, including the percent clay, the percent organic matter, the hydrologic group, the liquid limit, and the sorting of the burned soil grain-size distribution, either in combination or separately, were identified as significant in the modeling effort. These variables, acting in combination, are those that best separated basins that produced debris flows from those that did not produce debris flows. Additional measures of gradient, aspect, burned extent, soil properties, and rainfall intensities were not significant variables in the logistic regression models. The physical significance of these findings requires further evaluation.

Although five models for fire-related probability were found to be statistically valid, comparisons of model predictions with actual debris-flow events indicate that two of the five models do a better job than the other three of predicting debris-flow probability in central Idaho. These findings point to the necessity of model verification for specific settings, and they indicate that some of the models may be better suited to different settings in the Intermountain West.

A multiple regression analysis indicated that the mean volume of debris-flow material that can exit a basin outlet can be represented as a combined effect of the area of the basin burned at a combination of high and moderate severities, the area of the basin having slopes greater than or equal to 30%, and the total storm rainfall. Additional measures of gradient, burned extent, and rainfall considered here produced less satisfactory models. As with the probability model, the physical significance of these findings requires further evaluation.

The parameters included in both the probability and volume models are considered to be possible first-order effects that can be rapidly evaluated immediately after a fire. Other conditions than those used in the models may certainly affect debris-flow occurrence and volumes from recently burned basins. For example, an abundance of material stored in a channel, either dry ravel or alluvium, will affect debris-flow frequency and magnitude (Bovis and Jakob, 1999). A frequently occurring fire-flood sequence, like that which characterizes Southern California basins, may similarly limit material availability (e.g., Spittler, 1995). The erodibility of hillslope and channel materials will also impact debris-flow occurrence and magnitude.

Continuing work is focusing on assessing effectiveness of the probability models in different settings throughout the Intermountain

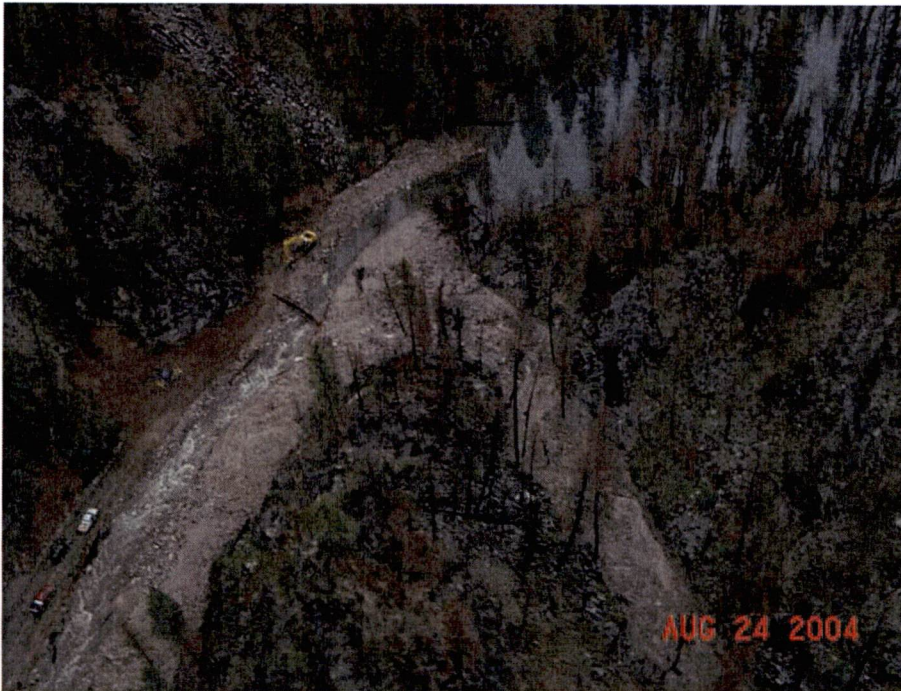

Figure 8. Aerial view of debris-flow deposits in the Middle Fork Boise River. The river was completely dammed at this location, and the road to Atlanta, Idaho, was destroyed. Photograph by Dave Hilgendorf, U.S. Department of Transportation Federal Highway Administration.

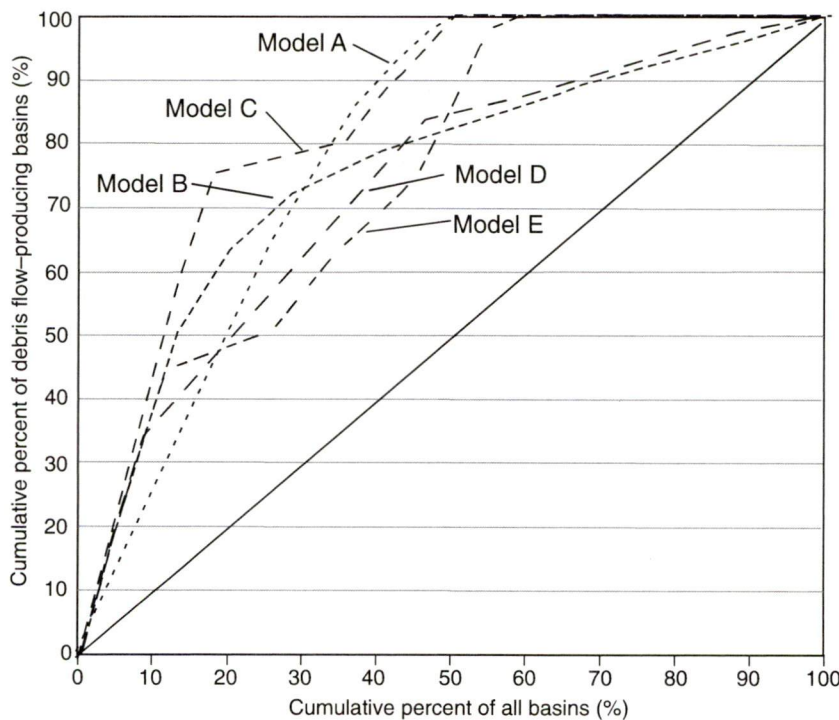

Figure 9. Prediction rate curves for probability models from Hot Creek fire showing the proportions of actual debris flow-producing basins to the predicted probabilities. Models A and C produced the best predictions of the 3 August 2003 event in this setting. The 1:1 line indicates a random distribution, and the steepest curves located closest to the y-axis indicate the strongest predictions.

West and developing probability and volume models that are specific to the Southern California climatologic and geologic setting. This effort will evaluate the time since the last fire and the last erosive event on debris-flow generation and magnitude, and will focus particularly on the development of methods to better characterize the effects of physical properties on the erodibility of surficial materials and debris-flow generation, and on the effect of different degrees of basin confinement on debris-flow occurrence.

ACKNOWLEDGMENTS

This project received funding through a number of different sources including: the U.S. Geological Survey (USGS) Landslide Hazards Program; U.S. Department of Agriculture (USDA) Forest Service Regions 1 and 4 Adaptive Management Program of the National Fire Plan; USDA Region 5, the Joint Fire Science Program, and CINDI, the USGS Center for Integrated Disaster Information. Many thanks are due to William Savage, Tom Spittler, Jon Major, Jennifer Pierce, Jerry DeGraff, and Chris Magirl for insightful and constructive reviews, to Dennis Helsel for statistical advice, to Angie Bell for model testing, and to Steven P. Garcia, Brandon Thurston, Kenneth L. Pierce, Nicole Davis, and Catherine McDonald for data collection and compilation efforts. Particular thanks are owed to T.J. Clifford, Greg Kuyumjian, Charlie Luce, Deborah Martin, John Moody, and Paul Santi for their always enjoyable and enlightening discussions in the field.

REFERENCES CITED

Beven, K.J., 2000, *Rainfall-Runoff Modeling: The Primer*: Chichester, UK, John Wiley & Sons Ltd., 360 p.

Biddinger, T., Gallegos, A.J., Janicki, A., TenPas, J., and Weaver, R., 2003, Grand Prix/Old Fire Burned-Area Report-FS-2500-8, USDA Forest Service FSH-2509-13, 56 p.

Bovis, M.J., and Jakob, M., 1999, The role of debris supply conditions in predicting debris flow activity: *Earth Surface Processes and Landforms*, v. 24, p. 1039-1054, doi: 10.1002/(SICI)1096-9837(199910)24:11<1039::AID-ESP29>3.0.CO;2-U.

Cannon, S.H., 2001, Debris-flow generation from recently burned watersheds: *Environmental & Engineering Geoscience*, v. 7, p. 321-341.

Cannon, S.H., and Gartner, J.E., 2005, Wildfire-related debris flow from a hazards perspective: Chapter 15, in Hungr, O., and Jacob, M., eds., *Debris Flow Hazards and Related Phenomena*: Berlin, Praxis, Springer-Verlag, p. 363-385.

Cannon, S.H., Powers, P.S., and Savage, W.Z., 1998, Fire-related hyperconcentrated and debris flows on Storm King Mountain, Glenwood Springs, Colorado, USA: *Environmental Geology*, v. 35, no. 2-3, p. 210-218.

Cannon, S.H., Kirkham, R.M., and Parise, M., 2001, Wildfire-related debris-flow initiation processes, Storm King Mountain, Colorado: *Geomorphology*, v. 39, p. 171-188, doi: 10.1016/S0169-555X(00)00108-2.

Cannon, S.H., Gartner, J.E., Parrett, C., and Parise, M., 2003a, Wildfire-related debris flow generation through episodic progressive sediment banking processes, western U.S.A., in Rickenmann, D., and Chen, C.L., eds., *Debris-Flow Hazards Mitigation—Mechanics, Prediction, and Assessment: Proceedings of the Third International Conference on Debris-Flow Hazards Mitigation*, Davos, Switzerland, 10-12 September 2003: Rotterdam, A.A. Balkema, p. 71-82.

Cannon, S.H., Gartner, J.E., Rupert, M.G., Michael, J.A., Djokic, D., and Sreedhar, S., 2003b, Emergency Assessment of Debris-Flow Hazards from Basins Burned by the Grand Prix and Old Fires of 2003, Southern

- California: U.S. Geological Survey Open-File Report 03-475, <http://pubs.usgs.gov/of/2003/ofr-03-475> (December 2003).
- Cannon, S.H., Gartner, J.E., Wilson, R.C., Bowers, J.C., and Laber, J.L., 2008, Storm rainfall conditions for floods and debris flows for recently burned areas in southwestern Colorado and Southern California: *Geomorphology*, v. 96, p. 250–269, doi: 10.1016/j.geomorph.2007.03.019.
- Chong, J., Renaud, J., and Ailsworth, E., 2004, Flash floods wash away lives, dreams: Families and friends gathered at campsites Christmas Day in the mountains had little or no warning. This is their story: *Los Angeles Times*, 3 January 2004, p. B.1.
- Chung, C.F., and Fabbri, A.G., 2003, Validation of spatial prediction models for landslide hazard mapping: *Natural Hazards*, v. 30, no. 3, p. 451–472, doi: 10.1023/B:NHAZ.0000007172.62651.2b.
- Cleveland, G.B., 1973, Fire and Rain = Mudflows, *Big Sur*, 1972: California Geology, v. 26, p. 127–135.
- Doehring, D.O., 1968, The effect of fire on geomorphic processes in the San Gabriel Mountains, California, in Parker, R.B., ed., *Contributions to Geology*, University of Wyoming, Laramie, v. 7, no. 1, p. 43–65.
- Doerr, S.H., Shakesby, R.A., and Walsh, R.P.D., 2000, Soil water repellency—Its causes, characteristics and hydrogeomorphological significance: *Earth-Science Reviews*, v. 51, p. 33–65, doi: 10.1016/S0012-8252(00)00011-8.
- Draper, N.R., and Smith, H., Jr., 1981, *Applied Regression Analysis* (2nd edition): New York, John Wiley and Sons, 709 p.
- Eaton, E.C., 1935, Flood and erosion control problems and their solution: *American Society of Civil Engineers Transactions*, v. 101, p. 1302–1362.
- Elliott, J.J., Smith, M.E., Friedel, M.J., Stevens, M.R., Bossong, C.R., Litke, D.W., Parker, R.S., Costello, C., Wagner, J., Char, S.J., Bauer, M.A., and Wilds, S.R., 2004, Analysis and Mapping of Post-Fire Hydrologic Hazards for the 2002 Hayman, Coal Seam, and Missionary Ridge Wildfires, Colorado: U.S. Geological Survey Scientific Investigations Report 2004–5300, 104 p.
- Gartner, J.E., 2005, Relations between Wildfire-Related Debris-Flow Volumes and Basin Morphology, Burn Severity, Material Properties and Triggering Storm Rainfall [M.S. thesis]: Boulder, Colorado, University of Colorado, 76 p.
- Gartner, J.E., Bigio, E.R., and Cannon, S.H., 2004, Compilation of Post Wildfire Runoff-Event Data from the Western United States: U.S. Geological Survey Open-File Report 2004–1085, <http://pubs.usgs.gov/of/2004/1085> (December 2004).
- Gartner, J.E., Cannon, S.H., Bigio, E.R., Davis, N.K., Parrett, C., Pierce, K.L., Rupert, M.G., Thurston, B.L., Trebish, M.J., Garcia, S.P., and Rea, A.H., 2005, Compilation of Data Relating to the Eroded Response of 606 Recently Burned Basins in the Western U.S.: U.S. Geological Survey Open File Report 2005–1218, <http://pubs.usgs.gov/of/2005/1218> (July 2005).
- Gartner, J.E., Cannon, S.H., Santi, P.M., and Dewolfe, V.G., 2008, Empirical models to predict the volumes of debris flows generated by recently burned basins in the western U.S.: *Geomorphology*, v. 96, p. 339–354, doi: 10.1016/j.geomorph.2007.02.033.
- Griffiths, P.G., Webb, R.H., and Melis, T.S., 2004, Frequency and initiation of debris flows in Grand Canyon, Arizona: *Journal of Geophysical Research*, v. 109, p. F04002, doi: 10.1029/2003JF000077.
- Helsel, D.R., and Hirsch, R.M., 2002, *Statistical Methods in Water Resources*: U.S. Geological Survey Techniques of Water Resources Investigations, Book 4, Chapter A3, 510 p., [http://pubs.usgs.gov/twri/twri4a3/html/pdf\\_new.html](http://pubs.usgs.gov/twri/twri4a3/html/pdf_new.html) (August 2005).
- Horton, R.E., 1932, Drainage basin characteristics: *Eos* (Transactions, American Geophysical Union), v. 13, p. 350–361.
- Hosmer, D.W., and Lemeshow, S., 2000, *Applied Logistic Regression* (2nd edition): New York, John Wiley & Sons, Inc., 375 p.
- Inman, D.L., 1952, Measures for describing the size distribution of sediments: *Journal of Sedimentary Petrology*, v. 22, p. 125–145.
- Iverson, R.M., 1997, The physics of debris flow: *Reviews of Geophysics*, v. 35, p. 245–296, doi: 10.1029/97RG00426.
- Key, C.H., and Benson, N.C., 2006, Landscape Assessment—Ground measure of severity, the Composite Burn Index and Remote sensing of severity, the Normalized Burn Ratio, in Lutes, D.C., Keane, R.E., Caratti, J.F., Key, C.H., Benson, N.C., Sutherland, S., and Gangi, L.G., FIREMON: Fire effects monitoring and inventory system: USDA Forest Service, Rocky Mountain Research Station, Ogden, Utah: General Technical Report, RMRS-GTR-164-CD, p. LA 1–51, [http://frames.nbii.gov/projects/firemon/FIREMON\\_LandscapeAssessment.pdf](http://frames.nbii.gov/projects/firemon/FIREMON_LandscapeAssessment.pdf).
- Kinner, D.A., and Moody, J.A., 2007, Infiltration and Run-off Measurements on Steep Burned Hillslopes using a Rainfall Simulator with Variable Rain Intensities: U.S. Geological Survey Scientific Investigations Report 2007–5211, 64 p.
- Klienbaum, D.G., 1994, *Logistic Regression, a Self-Learning Text*: New York, Springer-Verlag, 282 p.
- Martin, D.A., and Moody, J.A., 2001, Comparison of soil infiltration rates in burned and unburned mountainous watersheds: *Hydrological Processes*, v. 15, p. 2893–2903, doi: 10.1002/hyp.380.
- Melton, M.A., 1965, The geomorphic and paleoclimatic significance of alluvial deposits in southern Arizona: *The Journal of Geology*, v. 73, p. 1–38.
- Meyer, G.A., 2002, Fire in western conifer forests—Geomorphologic and ecologic processes and climatic drivers: *Geological Society of America Abstracts with Programs*, v. 34, no. 6, p. 46.
- Meyer, G.A., and Wells, S.G., 1997, Fire-related sedimentation events on alluvial fans, Yellowstone National Park, U.S.A.: *Journal of Sedimentary Research*, v. 67, no. 5, p. 776–791.
- Meyer, G.A., Wells, S.G., and Jull, A.J.T., 1995, Fire and alluvial chronology in Yellowstone National Park—Climatic and intrinsic controls on Holocene geomorphic processes: *Geological Society of America Bulletin*, v. 107, p. 1211–1230, doi: 10.1130/0016-7606(1995)107<1211:FAACY>2.3.CO;2.
- Meyer, G.A., Pierce, J.L., Wood, S.H., and Jull, A.J.T., 2001, Fire, storms, and erosional events in the Idaho Batholith: *Hydrological Processes*, v. 15, p. 3025–3038, doi: 10.1002/hyp.389.
- Mitsopoulos, I.D., and Mironidis, D., 2006, Assessment of post fire debris flow potential in a Mediterranean type ecosystem: *WIT Transactions on Ecology and the Environment*, v. 90, p. 221–228.
- Moody, J.A., and Martin, D.A., 2001a, Post-fire, rainfall intensity–peak discharge relations for three mountainous watersheds in the western USA: *Hydrological Processes*, v. 15, p. 2981–2993, doi: 10.1002/hyp.386.
- Moody, J.A., and Martin, D.A., 2001b, Initial hydrologic and geomorphic response following a wildfire in the Colorado Front Range: *Earth Surface Processes and Landforms*, v. 26, p. 1049–1070, doi: 10.1002/esp.253.
- Moody, J.A., Martin, D.A., and Cannon, S.H., 2008, Post-wildfire erosion response in two geologic terrains in the western USA: *Geomorphology*, v. 95, p. 103–118, doi: 10.1016/j.geomorph.2007.05.011.
- Near, D.G., Ryan, K.C., and DeBano, L.F., 2005, Wildland Fire in Ecosystems—Effects of Fire on Soil and Water: U.S. Department of Agriculture Forest Service General Technical Report RMRS-GTR-42, Volume 4, 250 p.
- Nolan, B.T., and Clark, M.L., 1997, Selenium in irrigated agricultural areas of the western United States: *Journal of Environmental Quality*, v. 26, no. 3, p. 849–857.
- O'Brien, J.S., 1993, FLO-2D Two-Dimensional Flood Routing System, Version 2001.06: Nutrioso, Arizona, FLO-2D Software, Inc., CD-ROM.
- Parsons, A., Jarvis, B., and Orleman, A., 2002, Mapping of post-wildfire burned severity using remote sensing and GIS, in *Proceedings of 22nd Annual ESRI Conference*, September 2002: Redlands, California, Environmental Systems Research Institute, Inc, <http://proceedings.ersri.com/library/userconf/proc02/pap0431/p0431.htm> (August 2005).
- Pierson, T.C., 2005, Distinguishing between Debris Flows and Floods from Field Evidence in Small Watersheds: U.S. Geological Survey Fact Sheet 2004–3142, 4 p.
- Pinter, N., and Vestal, W.D., 2005, El Niño–driven landsliding and postgrazing recovery, Santa Cruz Islands, California: *Journal of Geophysical Research*, v. 110, p. F2, doi: 10.1029/2004JF00203.
- Rupert, M.G., Cannon, S.H., and Gartner, J.E., 2003, Using Logistic Regression to Predict the Probability of Debris Flows Occurring in Areas Recently Burned by Wildland Fires: U.S. Geological Survey Open-File Report 03–500, <http://water.usgs.gov/pubs/of/2003/ofr03500> (November 2003).
- Santi, P.M., deWolfe, V.G., Higgins, J.D., Cannon, S.H., and Gartner, J.E., 2008, Source of debris flow material in burned areas: *Geomorphology*, v. 96, p. 310–321, doi: 10.1016/j.geomorph.2007.02.022.
- Schwartz, G.E., and Alexander, R.B., 1995, Soils data for the Conterminous United States Derived from the NRCS State Soil Geographic (STATSGO) Data Base: U.S. Geological Survey Open-File Report 95–449, <http://water.usgs.gov/lookup/getspatial?ussoils> (September 2003).
- Scott, K.M., 1971, Origin and Sedimentology of 1969 Debris Flows near Glendora, California: U.S. Geological Survey Professional Paper 750-C, p. C242–C247.
- Shakesby, R.A., and Doerr, S.H., 2006, Wildfire as a hydrological and geomorphological agent: *Earth-Science Reviews*, v. 74, p. 269–307, doi: 10.1016/j.earscirev.2005.10.006.
- Spittler, T.E., 1995, Fire and debris flow potential of winter storms, in Keely, J.E., and Scott, T., eds., *Brushfires in California Wildlands—Ecology and Resource Management*: Fairfield, Washington, International Association of Wildland Fire, p. 113–120.
- SPSS, Inc., 2000, SYSTAT 10, *Statistics I—Software Documentation*: Chicago, Illinois, SPSS, Inc., 663 p.
- Swanson, F.J., 1981, Fire and geomorphic processes, in Mooney, H.A., Bonnicksen, T.H., Christensen, N.L., Lotan, J.E., and Reiners, W.A., eds., *Fire Regimes and Ecosystem Properties*: U.S. Department of Agriculture Forest Service General Technical Report WO-26, p. 401–420.
- Swanston, D.N., 1991, Natural processes, in Meehan, W.L., ed., *Influences of Forest and Rangeland Management on Salmonoid Fishes and their Habitat*: American Fisheries Society Special Publication 19, p. 139–179.
- Troxell, H.C., and Peterson, J.Q., 1937, Flood in La Canada Valley, California: U.S. Geological Survey Water-Supply Paper 796-C, p. 53–98.
- Weight, W.D., and Johansen, E.A., 2004, Quantifying the variables causing debris flows in drainages ravaged by wildfire, in MacLaughlin, M.M., and McNearney, R.L., eds., *Proceedings of the 39th Symposium on Engineering Geology and Geotechnical Engineering*, 18–19 May 2004: Butte, Montana, Montana Tech of the University of Montana, p. 131–147.
- Wells, H.G., 1987, The effects of fire on the generation of debris flows in Southern California, in Costa, J.E., and Wiecek, G.F., eds., *Debris Flows/Avalanches—Process, Recognition, and Mitigation*: Geological Society of America, *Reviews in Engineering Geology*, v. VII, p. 105–114.
- Westerling, A.L., Hidalgo, H.G., Cayan, D.R., and Swetnam, T.W., 2006, Warming and earlier spring increase in western U.S. forest wildfire activity: *Science*, v. 313, p. 940–943, doi: 10.1126/science.1128834.
- Wohl, E.E., and Peatree, P.P., 1991, Debris flows geomorphic agents in the Huachuca Mountains of southeastern Arizona: *Geomorphology*, v. 4, p. 273–292, doi: 10.1016/0169-555X(91)90010-8.
- Wondzell, S.M., and King, J.G., 2003, Post-fire erosional processes in the Pacific Northwest and Rocky Mountain regions: *Forest Ecology and Management*, v. 178, p. 75–87, doi: 10.1016/S0378-1127(03)00054-9.
- Ziemer, R.R., 1981, Roots and the stability of forested slopes: *International Association of Hydrologic Science*, v. 132, p. 343–357.

MANUSCRIPT RECEIVED 7 MAY 2008  
 REVISED MANUSCRIPT RECEIVED 9 OCTOBER 2008  
 MANUSCRIPT ACCEPTED 11 OCTOBER 2008

Printed in the USA

## EFFECTIVENESS OF DEBRIS FLOW MITIGATION METHODS IN BURNED AREAS

Paul M. Santi<sup>1</sup>, Victor G. deWolfe<sup>2</sup>, Jerry D. Higgins<sup>3</sup>, Susan H. Cannon<sup>4</sup> & Joseph E. Gartner<sup>5</sup>

<sup>1</sup> Colorado School of Mines (e-mail: psanti@mines.edu)

<sup>2</sup> Deere & Ault Consultants, Inc. (e-mail: victor.dewolfe@deereault.com)

<sup>3</sup> Colorado School of Mines (e-mail: jhiggins@mines.edu)

<sup>4</sup> U.S. Geological Survey (e-mail: cannon@usgs.gov)

<sup>5</sup> U.S. Geological Survey (e-mail: jegartner@usgs.gov)

**Abstract:** The fire-flood sequence, in which recently burned areas generate debris flows and floods in response to relatively small rainstorms, is common in the Western United States. To reduce the likelihood and magnitude of these debris flows, hillslopes and channels are often treated by mulching, seeding, and construction of erosion barriers and fences. The effectiveness of these treatment methods in reducing debris-flow volume has not been thoroughly evaluated; therefore, the goal of this study was to quantify the effectiveness of post-fire debris flow mitigation techniques. Debris volumes were measured and sediment sources were identified for 46 recent debris-flow events. Graphs of debris flow volume accumulation along the length of the flowpath were generated to identify sources of debris and to develop a predictive model to estimate expected debris-flow volumes. Extensive field observations and interpretations of surveys of wildfire emergency response personnel provided additional information on effectiveness and applicability of various treatment methods. Based on this information we conclude that hillslope treatments are most effective in reducing water runoff and enhancing infiltration, and channel treatments are effective at capturing debris and reducing potential for debris flow growth. Engineering design, installation methods, density of treatment, and maintenance of mitigation elements are critical to their success.

### INTRODUCTION

The vulnerability of recently burned areas to debris flows has been shown by a number of research efforts, including Wells (1987), Spittler (1995), Cannon (2001), Moody and Martin (2001), Wondzell and King (2003), and Meyer et al. (2005), for example. Wildfire enhances runoff by consuming rainfall-intercepting canopy and litter, and it reduces infiltration by formation of water repellent soils and through introduction of fine ash (Cannon and Gartner, 2005). Consequently, debris flows can be generated in burned areas from smaller rainfall events than would be needed to generate flows in unburned areas.

To reduce the potential for debris flow occurrence and also the size of flows that do occur, typical mitigation methods include both widespread hillslope treatments as well as more focused channel treatments. Santi et al., (2006) concluded that hillside treatments reduce debris flow potential by increasing infiltration of rainfall, reducing runoff, and thereby reducing the water available within the stream channel that could mobilize sediment into a debris flow. They also noted that channel treatment methods both reduced the volume of debris flows and reduced the capacity for debris flows to grow in transit by incorporating channel sediment into the moving flow.

The most commonly applied hillside treatments are seeding, construction of log erosion barriers, and mulching (Robichaud et al., 2000). Seeding incorporates both aerial and hand-spread distribution of fast growing plant seed intended to re-establish a vegetative cover as quickly as possible. The roots of the plants stabilize soil material, reduce the effects of raindrop impact, and increase infiltration (Miles, 2005). Seeding is generally considered a short-term erosion control method, most effective within one to three years following a fire, as plants will not establish themselves immediately, and natural vegetation will take over after a few years (Santi et al., in review).

Log erosion barriers (LEBs) are felled and limbed trees, aligned along contour, and held in place with stumps or wooden stakes (deWolfe et al., in review). Their intent is to disrupt overland flow, reduce runoff velocity and erosion potential, and to enhance infiltration. Other barrier materials, such as straw wattles, function similarly. LEBs can serve for both immediate and short-term mitigation.

Mulching includes the spreading of organic material, often with a binder or "tackifier", to reduce the effects of raindrop impact, disperse overland flow, and enhance reestablishment of vegetation (deWolfe et al., in review). It may be spread aerially or by hand, and is considered both immediate and short-term mitigation.

Channel treatments often include debris racks and fences, check dams, debris basins, silt fences, and deflection berms. Debris racks are engineered cage-walls designed to trap coarse debris and pass finer sediment and water. They are often located in front of culverts or bridges to protect those structures from clogging and damage. Debris fences are flexible versions of debris racks, constructed from ring-nets and fencing material rather than solely from concrete and thick-walled pipes.

Check dams are small dams, often built in series within channels, aimed at inducing deposition of debris in increments along the length of the channel. Debris basins are usually not constructed in series, but consist of individual, large dams, usually built near the base of the canyon. Silt fences are thin geotextile fabric barriers supported by wooden stakes or rebar. They are installed in series across the channel with the intent of intercepting debris in increments much like check dams. Deflection berms are earthen, timber, concrete, or rock walls strategically placed and aligned to direct debris flows away from valuable structures and into areas where the impacts of the debris will be minimal.

While widespread in use, the effectiveness of these treatment methods in reducing debris-flow volume has not been thoroughly or quantitatively evaluated. The goals of this study are to: assemble previously published evaluations of effectiveness, quantitatively assess the impacts of some of these methods on debris flow volume, and conduct extensive field observations in numerous burned areas to directly evaluate various mitigation methods.

## **PREVIOUS WORK**

Detailed discussions of previous research evaluating the effectiveness of erosion control and debris flow control methods are presented in deWolfe et al. (in review) and deWolfe (2006). An abbreviated summary of those discussions is included below. Most previous research in burned areas evaluated erosion control rather than debris flow control (Miles, 2005; Robichaud et al., 2000; Beyers et al., 1998; Wohlgemuth et al., 1998, 1999, 2001, for example), and much of this previous work was at the plot scale or monitored individual hillslopes, rather than entire burned watersheds. However, it may be assumed that the performance of mitigation measures at the plot

or hillslope scale will also reflect their performance at the watershed scale, at least with regards to reducing overland flow and enhancing infiltration. Therefore, our discussion will not be limited to debris-flow-specific treatments.

The broadest evaluation of erosion control effectiveness was a compilation of surveys of emergency response personnel, published by Robichaud et al. (2000). Four categories of effectiveness were used: excellent, good, fair, and poor. The rating for mulching was considered dominantly "excellent," and hand seeding was dominantly "good." LEB performance was variable, with many responses in the "good" and "excellent" categories. Aerial seeding was evenly split amongst the four categories, and check dams also received mixed reviews, with many "fair" and "poor" ratings.

Other studies assessed only one erosion control method at a time. Most seeding studies produced negative results, where treated slopes did not show significantly less erosion than untreated slopes (Wagenbrenner et al., 2006; Taskey et al., 1989; Beyers et al., 1998; Wohlgemuth et al., 1998; Roby, 1989; Geier-Hayes, 1997; and Beyers, 2004).

Conversely, the majority of the mulching studies reviewed concluded that proper application of mulch reduced erosion effectively (Wagenbrenner et al., 2006; Bautista et al., 1996; Kay, 1983; Buxton and Caruccio, 1979; Miles et al., 1989; Robichaud, 2006; and Dean, 2001).

The performance of LEBs was mixed. Gartner (2003) and Wohlgemuth et al. (2001) concluded that LEBs were easily bypassed by flowing water and were mostly ineffective. Dean (2001) considered them to be effective, but at a site that had also been mulched and seeded. Robichaud (2006) and Wagenbrenner et al. (2006) found LEBs to be effective only during low to moderate intensity rainfall events and not during high intensity events.

No studies evaluating the effectiveness of channel treatment measures were found, although there are published reports of the use of ring-net debris fences (Thommen and Duffy, 1997; Duffy and DeNatale, 1996) and check dams (Okubo et al., 1997), the function of check dams in unburned watersheds (Leys and Hagen, 1971; Eisbacher and Clague, 1984; Government of Japan, 1984; Thurber Consultants, 1984; Heierli and Merk, 1985; Whittaker et al., 1985; and Chatwin et al., 1994), and reports of check dam failure (Robichaud, 2006; White et al., 1998; and Hubbert and Associates, 2005).

Debris basins and deflection berms may be constructed at the mouth of a debris-producing watershed. They require larger amounts of space, but are considered very effective if designed and constructed properly (Santi et al., 2006).

## **DEBRIS VOLUME MEASUREMENTS**

Debris volumes were measured for 46 debris-flow events in California, Utah, and Colorado (Santi et al., in review). For each canyon, a series of channel cross sections were surveyed up the length of the canyon. By interpreting the erosion and deposition evidence at each cross section, the area of scour or debris deposition was calculated. The incremental volume of debris incorporated into the passing flow or deposited as levees was then calculated as the average for two successive cross sections, multiplied by the distance between them. These incremental volumes were plotted as both the cumulative volume along the length of the channel and the total volume eroded and deposited, as shown on Figure 1. These graphs show sources of debris, whether from side channels, erosion of the main channel, or hillslope rilling. The slope of the graph indicates the yield rate, or intensity of scour and erosion.

Based on an analysis of these graphs, Santi et al. (in review) concluded that the highest contribution of sediment to a debris flow (at least 90%) was from channel erosion, with an average of one-fourth of that sediment coming from side channels and three-fourths from the main channel. Hillslope rilling accounted for an average of 3% of the total debris, with a maximum measured amount of 10%. Because of these results, they concluded that mitigation methods within the channel would be beneficial in reducing scour and growth of debris flows, and mitigation methods applied on the hillsides should be aimed at reducing water runoff rather than focusing solely on erosion control.

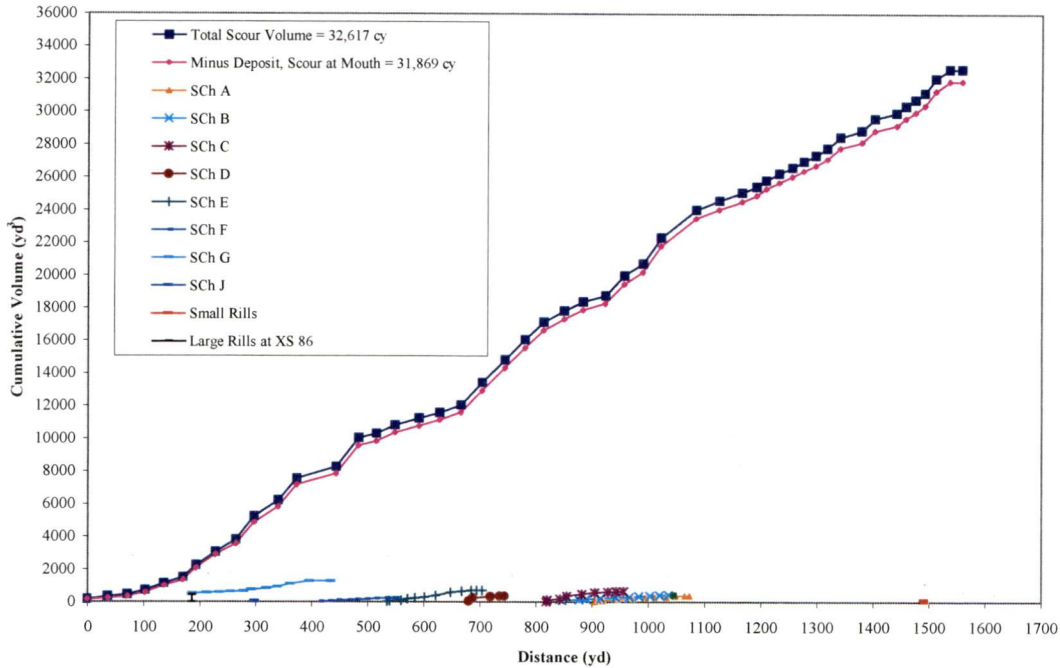

**Figure 1.** Example of a cumulative debris flow volume graph produced for this study, from Devore, CA. Note the contribution of side channels (“Sch”) and rills, as well as the effect of levee deposition (pink “Minus Deposit” line).

## VARIABILITY IN DEBRIS PREDICTION

Using data from Santi et al. (in review), Santi et al. (2006), and U.S. Army Corps of Engineers (in press), Gartner (2005) used multiple regression analysis to develop an equation to predict debris-flow volume in burned areas in the Western U.S.:

$$V = EXP(0.65(\ln S) + 0.86(B^{1/2}) + 0.22(R^{1/2}) + 6.46) \quad (\text{Equation 1})$$

Where:  $V$  = Volume ( $m^3$ )  
 $S$  = area with slopes  $\geq 30\%$  ( $km^2$ )  
 $B$  = area burned at moderate and high severity ( $km^2$ )  
 $R$  = storm rainfall total (mm)

This model was considered the best of several generated, based on the  $R^2$  of 0.83, the residual standard error of 0.90, the ease in measuring the input parameters, and support from independent validation with data points outside the set used in the regression (Gartner, 2005).

Santi et al. (2006) used Equation 1 to calculate the volume of material that could issue from a basin outlet for each of the basins in their study that had been treated with some kind of erosion control mitigation. Of the 46 basins studied, 12 included some erosion control mitigation, the largest of which was 2 km<sup>2</sup> in area. Treatments included various concentrations and coverages of seeding, mulching, and LEBs. Figure 2 shows the relationship between measured and predicted volumes. Values for six of the 12 basins (50%) are within one standard error of the predicted value, while five others are very close to the error envelope. Eight of the 12 data points (66%) show lower measured volume than was predicted, and four of the points (33%) are completely above the error envelope. Only four points (33%) show more measured volume than predicted, with two of those below (17%) the error envelope.

The fact that the majority of the predicted volumes are less than the measured volumes indicates that erosion and sediment control treatments can be effective in reducing debris-flow volume. The point to the far left is the most extreme case, and is discussed in more detail in the section below for Lemon Dam.

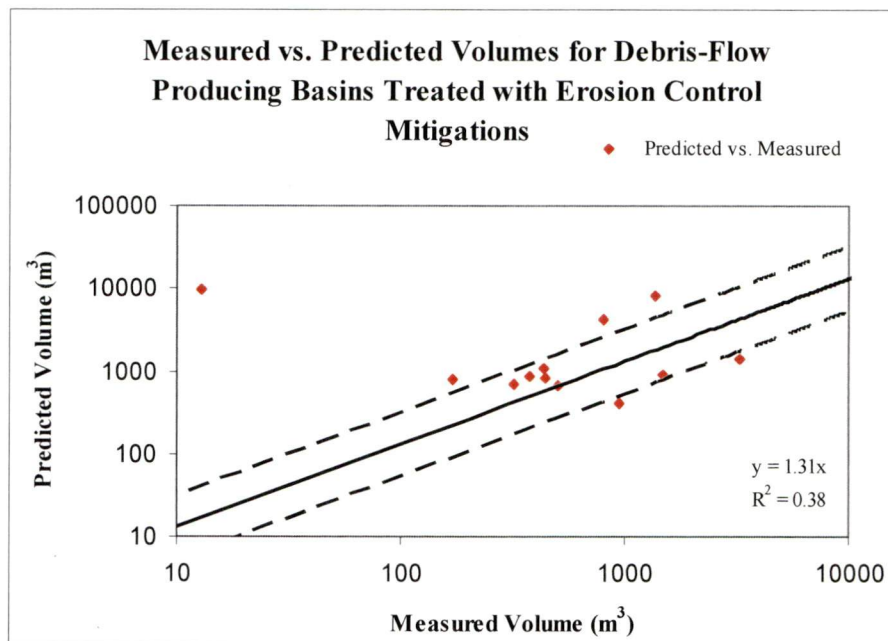

**Figure 2.** Relationship between measured and predicted volumes for treated basins. Dashed lines represent one standard deviation off the mean (68% confidence interval).

## FIELD OBSERVATIONS

The field observations conducted for this study are reported in detail in deWolfe (2006) and Santi et al. (2006) and are summarized below. The field work included analysis of 46 burned watersheds producing debris flows and less detailed observation of several other burned watersheds.



Seeding did not appear to substantially reduce debris flow potential. Since seeding is a hillslope treatment method, its usefulness rests in its ability to reduce runoff and enhance infiltration. Because of the time required for germination, it was not effective for immediate treatment, and natural vegetation seemed to re-establish itself within the same time frame as seeded growth. Its effectiveness seemed to be improved when combined with mulch.

Mulch was effective at reducing surface runoff and enhancing infiltration, but only when placed properly. If evenly spread, as is usually done by hand, the mulch protects most of the soil. If spread by helicopter, the mulch was often clumped, providing poor coverage and preventing plant growth (Figure 3). Mulch was frequently redistributed by wind, which also resulted in clumping around trees and bushes and creating large areas with no coverage. Crimping of mulch into the soil, discussed in the next section, greatly improved its effectiveness.

LEBs can be effective at reducing hillslope runoff, as indicated in the next section, but are frequently undercut by runoff, rendering them ineffective. For example, deWolfe (2006) reports undercutting for a range of 17-83% of the LEBs in four different watersheds in the Missionary Ridge burn area in Colorado.



**Figure 3.** Poorly dispersed mulch applied by helicopter on burned slopes near Silverwood, CA. Note how clumping has prevented vegetation growth.

Check dams show promise as effective debris flow reducing structures, but only if designed and installed properly. They were successful at Lemon Dam in Colorado (see below), yet the dams failed and exacerbated the debris flow problem at the Piru Fire in California (Hubbert and Associates, 2005). Furthermore, they are expensive, labor intensive, and difficult to build in the steep upper reaches of channels where access is limited.

Silt fences were ineffective for erosion control as the fine mesh of the geotextile trapped fine sediment and water as well as coarse debris, causing them to be quickly filled and overwhelmed (Figure 4).



**Figure 4.** Failed silt fences near Farmington, UT.

Debris racks are less likely to be filled and overrun because their large size allows finer material and water to pass (Figure 5). Although limited observations were made, they performed well, as described in the next section.

While ring nets and deflection berms were observed at various sites within this study, their effectiveness could not be adequately gauged.

#### **CASE STUDY AT LEMON DAM**

Detailed case studies of the debris flow mitigation treatment and performance near Lemon Dam, Colorado are published in Coe (2006) and deWolfe et al. (in review) and summarized below. Because Lemon Dam is a critical part of the water supply system for the city of Durango, transport of sediment or debris flow into the reservoir following the 2002 Missionary Ridge Fire could have deteriorated water quality or interfered with the water intake system. The Florida Water Conservancy District (FWCD) was directed to prevent significant sediment movement into critical portions of the reservoir. Their mitigation efforts consisted of construction of LEBs, mulching, seeding, and construction of check dams and debris racks.



**Figure 5.** Debris rack installed near Lemon Dam, CO.

The LEBs at Lemon Dam appeared to have successfully reduced hillslope erosion and enhanced infiltration because they were constructed in dense concentrations and in conjunction with other erosion control measures. Ninety-three hectares of a severely burned watershed above the dam's spillway and intake structures were treated with concentrations between 220 and 620 LEBs/hectare. LEBs are usually applied to large areas in National Forests in concentrations of 100 LEBs/hectare (BAER, 2002). The LEBs were rehabilitated multiple times after being filled by hillside erosion during rainfall, by hand digging sediment from the uphill side and packing it under the downhill side of the barrier (Ey, 2004).

At Lemon Dam over 172 metric tons of mulch were spread by hand and crimped into over 100 hectares of burned slopes (WWE, 2005). Our field observations over the next three years indicated that the mulch remained in place, facilitated regrowth of vegetation, and protected the soil from erosion.

Critical areas near Lemon Dam were seeded at a rate of 67-84 kg/hectare (typical application concentrations are around 45 kg/hectare). Observations of those slopes show that spreading this concentration among crimped mulch helped re-establish a vegetative cover during the first growing season (Figure 6). We postulate that the mulch and LEBs reduced hillslope erosion and held the seeds in place until germination.

Thirteen earthen check dams were constructed in the main channel of Knight Canyon above Lemon Dam. Figure 7, taken on September 9<sup>th</sup>, 2003 (14 months after the fire, approximately 2-year recurrence interval storm), shows a check dam filled with an ash/mud deposit during a heavy rain in the watershed. In the background, another check dam can be seen in the series. The dams were monitored by the FWCD and cleaned out after such erosional events. The dams were properly constructed and sized, and effectively reduced both the volume of debris that reached the canyon mouth and the potential growth of the debris flow within the canyon (deWolfe et al., in review).

Five debris racks were constructed between October and December 2002. Only one rack was located in a channel that produced a debris-flow, intercepting ~130 m<sup>3</sup> of a debris-flow measured to be about 445 m<sup>3</sup> in total volume (Figure 7). The design of this debris rack prevented failure and allowed the fine material to continue down channel, where it was partially trapped by a second debris rack. Only muddy water reached the Florida River.

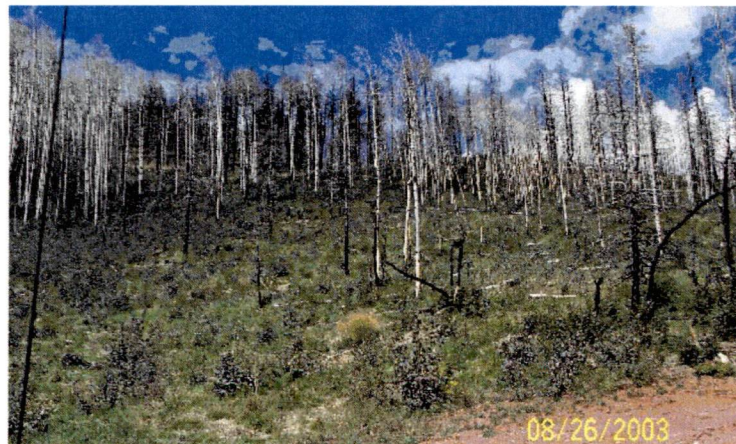

**Figure 6.** Natural and seeded revegetation near Lemon Dam, CO.



**Figure 7.** Check dam that captured ash/mud runoff following a rainstorm near Lemon Dam, CO.

The debris flow control methods at Lemon Dam were effective in virtually eliminating sedimentation into the reservoir, which can be attributed to a number of factors: the density of application of each mitigation method, the enhancement of methods working in concert, quality of installation, and rehabilitation of mitigation features to extend their useful life.

## CONCLUSIONS

As a result of this study, we conclude that 1) the vast majority of material in post-fire debris flows comes from erosion of the canyon channel and not from hillslope erosion, 2) based on predictive modelling, there is a slight, but measurable reduction in debris volume from hillside treatment by mulch, seeding, and log erosion barriers (although seeding alone does not appear to reduce erosion), 3) installation methods, density of treatment, and maintenance of mulch, seeding, and log erosion barriers are critical to their success, 4) check dams and debris racks, if constructed properly and in  $< 2\text{km}^2$  drainage watersheds with channel gradients less than 25 degrees (criteria suggested by Santi et al., 2006) have some potential for reducing debris-flow volume, 5) silt fences installed in channels were ineffective, as they quickly filled and were torn out.

**Acknowledgements:** This work was conducted under a grant from the Joint Fire Science Program, contract 03-1-4-14, as part of a larger study entitled “Evaluation of Post-Wildfire Debris Flow Mitigation Methods and Development of Decision-Support Tools.” The authors are grateful for field data collection by Morgan McArthur, Adam Prochaska, and Nate Soule.

**Corresponding author:** Dr. Paul M. Santi, Colorado School of Mines, Department of Geology and Geological Engineering, Golden, Colorado, 80401, United States of America. Tel: +1 303 273 3108. Email: psanti@mines.edu.

## REFERENCES

- BAER (Burned Area Emergency Response) Team. 2002. *Missionary ridge complex, Durango, Colorado June – July 2002: Burned area emergency stabilization and rehabilitation plan*. USDA Forest Service, Bureau of Land Management, U.S. Geological Survey, 251 p.
- BAUTISTA, S., BELLOT, J., & VALLEJO, V. 1996. Mulching treatment for postfire soil conservation in a semiarid ecosystem. *Arid Soil Research and Rehabilitation*, **10**, 235-242.
- BEYERS, J. 2004. *Postfire seeding for erosion control: Effectiveness and impacts on native plant communities*. USDA Forest Service. *Conservation Biology* **18** (4) 947-956. <http://fire.r9.fws.gov/ifcc/Esr/Library/Library.htm>. Accessed on 10/24/2005.
- BEYERS, J., WAKEMAN, C., WOHLGEMUTH, P., & CONARD, S. 1998. Effects of postfire grass seeding on native vegetation in southern California chaparral. *Proceedings, 19<sup>th</sup> annual forest vegetation management conference: wildfire rehabilitation*. Forest Vegetation Management Conference, Redding, California.
- BUXTON, H., & CARUCCIO, F. 1979. *Evaluation of selective erosion control techniques, piedmont region of S.E. United States*. Municipal Environmental Research Laboratory Office of Research and Development U.S. Environmental Protection Agency, Cincinnati, OH, EPA-600/2-79-124, 107 p.
- CANNON, S. 2001. Debris-flow generation from recently burned watersheds. *Environmental & Engineering Geoscience*. **7**(4), 321-341.
- CANNON, S. & GARTNER, J. 2005. *Runoff and erosion generated debris flows from recently burned basins*. Geological Society of America Annual Meeting, Salt Lake City, UT.
- CHATWIN, S., HOWES, D., SCHWAB, J., & SWANSTON, D. 1994. *A guide for management of landslide-prone terrain in the Pacific Northwest*. 2<sup>nd</sup> ed. B.C. Ministry of Forestry., Victoria, B.C. Land Management, Handbook 18. 220 p. <http://www.for.gov.bc.ca/hfd/pubs/Docs/Lmh/LMH-09.pdf>. Accessed on 2/12/2005.
- COE, J. 2006. *Mass wasting following the 2002 Missionary Ridge Fire near Durango Colorado, a field trip guidebook*. Shlemon Conference on Mass Wasting in Disturbed Watersheds, Association of Engineering and Environmental Geologists, 54 p.
- DEAN, A. 2001. *Evaluating effectiveness of watershed conservation treatments applied after the Cerro Grande Fire, Los Alamos, New Mexico*. MS thesis, University of Arizona, Tucson.
- DEWOLFE, V. 2006. *An evaluation of erosion control methods after wildfire in debris-flow prone areas*. M.S. thesis, Colorado School of Mines, Golden, CO. 185 P.
- DEWOLFE, V., SANTI, P., EY J., & GARTNER, J. In review. Effective debris flow mitigation at Lemon Dam, LaPlata County, Colorado. *Geomorphology*.
- DUFFY, J. & DENATALE, J. 1996. Debris flow mitigation using flexible barriers. *Proceedings of the 47<sup>th</sup> Annual Highway Geology Symposium*, 243-252 pp.
- EISBACHER, G. & CLAGUE, J. 1984. *Destructive mass movements in high mountains: hazard and management*. Geological Survey of Canada. Paper 84-16. 230 p.
- EY, J. 2004. Personal communication. Florida Water Conservancy District, Lemon Dam, Durango, Colorado.
- GARTNER, J. 2003. *Erosion after wildfire: the effectiveness of log erosion barriers*. M.S. Thesis. University of Colorado, Boulder, Colorado.
- GARTNER, J. 2005. *Relations between debris-flow volumes generated from recently burned basins and basin morphology, triggering storm rainfall and material properties*. M.S. thesis, University of Colorado, Boulder, CO. 73 P.
- GEIER-HAYES, K. 1997. The impact of post-fire seeded grasses on native vegetative communities in central Idaho. In Greenlee (ed) *Proceedings: first conference on fire effects on rare and endangered species and habitats*. International Association of Wildland Fire, Fairfield, Washington.
- GOVERNMENT OF JAPAN. 1984. *Basics of planning the measures against debris flows and planning countermeasure facilities against debris flow*. Ministry of Construction. 39p.
- HEIERLI, W. & MERK, A. 1985. Barriers for erosion control of mountain torrents. *Proceedings of the International Symposium on Erosion, debris flow and disaster prevention*. Tsukuba, Japan, pp. 375-380.
- HUBBERT AND ASSOCIATES. 2005. *Treatment effectiveness monitoring for Southern California wildfires: 2003 to 2004, the Cedar, Grand Prix/Old, Piru, and Padua Fires*. unpublished.
- KAY, B. 1983. *Straw as an erosion control mulch*. Agronomy Progress Report No. 140, Davis, CA: University of California Agricultural Experiment Station, 11 p.
- LEYS, E. & HAGEN, G. 1971. *Design of gravity dams against water pressure and earth pressure*. Imst Regional Construction Office, Torrent and Avalanche Control, Austria. 39 p. (in German).

- MEYER, G., PIERCE, J., & WELLS, S. 2005. *Runoff-generated debris flows in burned and unburned basins, Yellowstone National Park and Central Idaho*. Geological Society of America Annual Meeting, Salt Lake City, UT.
- MILES, S. *Listing of BAER Treatments: cost, risk, effectiveness, production rates and applications, Burned Area Emergency Response Lesson*. <http://www.fs.fed.us/r5/baer/4g.html>, Accessed on 2/10/2005.
- MILES, S., HASKINS, D., & RANKEN, D. 1989. Emergency burn rehabilitation; cost, risk, and effectiveness. In Berg, N. (technical coordinator) *Proceedings of the symposium on fire and watershed management*. General technical report PSW-GTR-109, U.S. Department of Agriculture Forest Service, Pacific Southwest Forest and Range Experiment Station, Berkeley, California.
- MOODY, J. & MARTIN, D. 2001. Initial hydrologic and geomorphic response following a wildfire in the Colorado Front Range. *Earth Surface Processes and Landforms*. **26**, 1049-1070.
- OKUBO, S., IKEYA, H., ISHIKAWA, Y., & YAMADA, T. 1997. Development of new methods for countermeasures against debris flows. In Armani, A. and Michiue, M. (eds) *Recent developments on debris flows, lecture notes in earth sciences Volume 64*. Springer-Verlag, New York, NY, pp. 166-185.
- ROBICHAUD, P. 2006. Personal communication. USDA Forest Service, Moscow, ID.
- ROBICHAUD, P., BEYERS, J., & NEARY, D. 2000. *Evaluating the effectiveness of postfire rehabilitation treatments general technical report RMRS-GTR-63*. Fort Collins. U.S. Department of Agriculture, Forest Service, Rocky Mountain Research Station. 85 p. [http://www.fs.fed.us/rm/pubs/rmrs\\_gtr63.pdf](http://www.fs.fed.us/rm/pubs/rmrs_gtr63.pdf). Accessed on 10/14/2005.
- ROBY, K. 1989. Watershed response and recovery from the Will Fire: ten years of observation. In Berg, N. (technical coordinator) *Proceedings of the symposium on fire and watershed management*. General technical report PSW-GTR-109, U.S. Department of Agriculture Forest Service, Pacific Southwest Forest and Range Experiment Station, Berkeley, California.
- SANTI, P., DEWOLFE, V., HIGGINS, J., CANNON, S., & GARTNER, J. In review. Sources of debris flow material in burned areas. *Geomorphology*.
- SANTI, P., HIGGINS, J., CANNON, S., & DEGRAFF, J. 2006. *Evaluation of post-wildfire debris flow mitigation methods and development of decision-support tools*. Final report to the Joint Fire Science Program, available at [http://jfsp.nifc.gov/JFSP\\_Products\\_5.htm](http://jfsp.nifc.gov/JFSP_Products_5.htm). 50 p.
- SPITTLER, T. 1995. Fire and the debris flow potential of winter storms. In: KEELEY, J. and SCOTT, T. (eds), *Brushfires in California wildlands: Ecology and resource management*. International Association of Wildland Fire, Fairfield WA. pp. 113- 120.
- TASKEY, R., CURTIS, C., & STONE, J. 1989. Wildfire, ryegrass seeding, and watershed rehabilitation. In Berg, N. (technical coordinator) *Proceedings of the symposium on fire and watershed management*. General technical report PSW-GTR-109, U.S. Department of Agriculture Forest Service, Pacific Southwest Forest and Range Experiment Station, Berkeley, California.
- THOMMEN, R., & DUFFY, J. 1997. *Testing and application of flexible wire rope netting barriers to retain mud and debris flow*. Geobrugg Technical Bulletin #10.
- THURBER CONSULTANTS LTD. 1984. *Debris torrents, a review of mitigative measures*. Report to B.C. Ministry of Transportation and Highways, Victoria, B.C.
- U.S. ARMY CORPS OF ENGINEERS. In press. *Analyses of the debris and sedimentation impacts at selected debris basins associated with the wildfires of 2003 and the December 25, 2003 storm*. Hydrology and Hydraulics Section, U.S. Army Corps of Engineers, Los Angeles District. 45 p.
- WAGENBRENNER, J., MACDONALD, L., & ROUGH, D. 2006. Effectiveness of three post-fire rehabilitation treatments in the Colorado Front Range. *Hydrological Processes*, **20** pp. 2989-3006.
- WELLS, W. 1987. The effects of fire on the generation of debris flows in southern California. In: COSTA, J. and WIECZOREK, G. (eds) *Debris flow/avalanches: Process, recognition, and mitigation, Reviews in Engineering Geology Volume VII*. Geological Society of America, Boulder, CO. pp. 105-114.
- WHITE, S., GARCIA-RUIZ, J., MARTI, C., VALERO, B., ERREA, M., & GOMEZ-VILLAR, A. 1998. The 1996 Biescas campsite disaster in the Central Spanish Pyrenees, and its temporal and spatial context. *Hydrological Processes*, **11**(14) pp. 1797-1812.
- WHITTAKER, J., SCHAECHLI, U., & JAEGGI, M. 1985. Design problems with torrent check dams in Switzerland. *Proceedings of the International Symposium: Erosion, debris flow and disaster prevention, Tsukuba, Japan*, pp. 387-394.
- WOHLGEMUTH, P., BEYERS, J., WAKEMAN, C., & CONARD, S. 1998. Effects of fire and grass seeding on soil erosion in southern California chaparral. *Proceedings, 19<sup>th</sup> annual forest vegetation management conference: wildfire rehabilitation*. Forest Vegetation Management Conference. Redding, California.

- WOHLGEMUTH, P., BEYERS, J., & CONARD, S. 1999. Postfire hillslope erosion in southern California chaparral: a case study of prescribed fire as a sediment management tool. In A. Gonzalez-Caban, A. and Omi, P. (technical coordinators) *Proceedings of a symposium on fire economics, planning, and policy: bottom lines*. General technical report PSW-GTR-173, U.S. Department of Agriculture Forest Service, Pacific Southwest Research Station, Albany, California.
- WOHLGEMUTH, P., HUBBERT, K., & ROBICHAUD, P. 2001. The effects of log erosion barriers on post-fire hydrologic response and sediment yield in small forested watersheds, southern California. *Hydrological Processes*, **15**, 3053-3066.
- WONDZELL, S. & KING, J. 2003. Post-fire erosional processes in the Pacific Northwest and Rocky Mountain Regions. *Forest Ecology and Management*. **178**, 75-87.
- WWE, (Wright Water Engineers) Inc. 2005. *Florida watershed post-fire rehabilitation project, section 319 grant report*. Wright Water Engineers, Inc., Durango, CO, unpublished.

# Debris Basin and Deflection Berm Design for Fire-Related Debris-Flow Mitigation

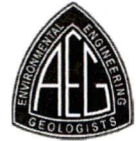

ADAM B. PROCHASKA<sup>1</sup>

PAUL M. SANTI

JERRY D. HIGGINS

*Colorado School of Mines, Department of Geology and Geological Engineering,  
1516 Illinois Street, Golden, CO 80401*

**Key Terms:** *Debris Flow, Fire-Related, Mitigation, Design, Basin, Deflection Berm*

## ABSTRACT

Debris flows are hazardous because of their poor predictability, high impact forces, and ability to deposit large quantities of sediment in inundated areas. To minimize the risk to developments on alluvial fans, debris-flow mitigation structures may be required. This study reviewed the state of practice for the design of two types of debris-flow mitigation structures: basins and deflection berms. Published guidelines for these structures are rare, and there appears to be little standardization. Recommended design improvements, particularly for fire-related debris flows, include incorporating several recent developments in debris-flow mitigation design, reducing subjectivity, and enhancing the technical basis for the designs. Specific shortcomings of existing design methodologies include techniques for predicting debris-flow volume, specifications for berm geometry, impact loading considerations, and lack of flexibility in outlet works design, among others. Proposed solutions and guidelines for these issues are presented.

## INTRODUCTION

With an ever increasing population, urban development will need to further encroach into geologically hazardous areas. One such example of a hazardous area is an alluvial fan, which may be susceptible to debris flows. VanDine (1985) defines a debris flow as being “a mass movement that involves water-charged, predominantly coarse-grained inor-

ganic and organic material flowing rapidly down a steep, confined, preexisting channel.” Debris flows are hazardous because of their poor predictability, high impact forces, and ability to deposit large quantities of sediment in inundated areas (Jakob and Hungr, 2005).

Debris-flow hazards increase following a forest fire because of the increased rainfall runoff and soil erodibility that result from the removal of vegetation (Cannon and Gartner, 2005). McDonald and Giraud (2002) and Giraud and McDonald (2007) describe the impacts of recent fire-related debris flows in Utah. Fire-related debris flows initiated from several recently burned drainages on Dry Mountain in 2002 and 2004. These flows inundated a subdivision near Santaquin (Figure 1) and caused \$500,000 in damage to 32 homes.

To minimize the risk to developments on alluvial fans, debris-flow mitigation structures may be required. Two types of mitigation structures are debris-flow basins and deflection berms. Debris-flow basins are closed structures that are designed to contain all or much of the volume of a debris flow. Deflection berms are open structures that are designed to direct debris flows toward low-risk areas on alluvial fans. Current technical literature describes different debris-flow mitigation structures and also presents equations for the estimation of design parameters, but do not specifically outline how the design equations should be incorporated into the design of the structures. One of the few published systems, by Los Angeles (L.A.) County (Easton et al., 1979; Nasser et al., 2006), includes standard procedures for the design of debris-flow basins and could benefit from several recent developments in debris-flow mitigation design. No guidelines exist for the design of debris-flow deflection berms; government agencies have been using design procedures that contain a degree of subjectivity and could benefit from a more robust technical basis.

This article first briefly summarizes debris-flow mitigation design aspects reported in the technical

<sup>1</sup>Present Address: RJH Consultants, Inc., 9800 Mt. Pyramid Court, Suite 330, Englewood, CO 80112. Phone: 303-225-4611, Fax: 303-225-4615.





Figure 1. Inundation of a subdivision near Santaquin, Utah, by fire-related debris flows (from Elliot, 2007).

literature. Next, a detailed review is presented of the design methodology for L.A. County debris basins (Easton et al., 1979; Nasseri et al., 2006) and the deflection berm design policies of the Oregon Department of Forestry (Hinkle, 2007) and the Natural Resources Conservation Service (NRCS) (Rogers, 2007). These procedures are some of the only published systems available and are fairly specific to the geology and conditions for which they were prepared. Finally, potential improvements for these design methodologies with respect to recent developments in debris-flow mitigation design are presented, specifically for fire-related debris flows. A quantitative methodology for the design of deflection berms is also presented.

## BACKGROUND

Discussion of various debris-flow mitigation structures can be found in several sources within the technical literature (Hungur et al., 1987; VanDine, 1996; Fiebiger, 1997; VanDine et al., 1997; Heumader, 2000; and Huebl and Fiebiger, 2005). Equations to aid in the design of these mitigation structures have been outlined by various authors (Hungur et al., 1984; VanDine, 1996; and Lo, 2000). However, none of these sources gives detailed guidelines as to how the debris-flow characteristics that are estimated from the design equations should be incorporated into the design of the mitigation structures.

Giraud (2005) provides guidelines for evaluating the debris-flow hazard of areas, but focuses primarily on the geological aspects of debris-flow occurrence and

not on the actual design of mitigation. VanDine (1996) includes conceptual sketches of different mitigation structures, but does not provide a direct way of estimating the required size and strength of the conceptual structures based on properties of the debris flow. Sun and Lam (2004) provide a simplified methodology for the design of various debris flow barriers (concrete walls, gabions, and fences). Various possible locations for barrier placement are determined from the channel profile and the anticipated event volume. The required barrier size and strength at each location are also dependent on the design volume. However, this design method is limited to debris flows with volumes less than  $600 \text{ m}^3$  (Sun and Lam, 2004). Bradley et al. (2005) discuss the design of debris-controlling structures, but these designs are only applicable to debris carried by normal streamflow.

Specific design methods for debris-flow basins and deflection berms will be looked at in detail and are assumed to represent the state of practice in general. L.A. County has developed detailed manuals for the design of debris basins (Easton et al., 1979; Nasseri et al., 2006), but these manuals do not include several aspects of debris-flow mitigation design that are found in recent technical literature. In Oregon, deflection berms used in forested regions are subjectively designed, using conservative qualitative judgment. The NRCS applies a bulking factor to clear-water flow to design the flow capacity of deflection berms. Several designers of other debris-flow mitigation structures recently constructed in Colorado were also contacted, but they declined to respond with their design methodologies.

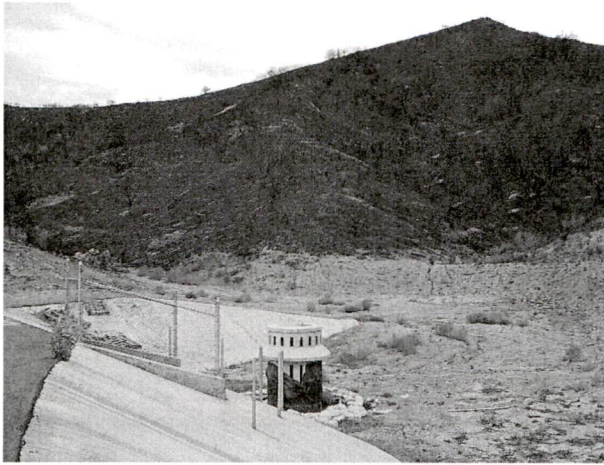

Figure 2. Photo of the Dewitt Canyon Debris Basin in L.A. County (courtesy of Ben Willardson).

### STATE OF PRACTICE FOR DEBRIS-FLOW BASIN DESIGN

L.A. County has developed detailed manuals for the design of debris-flow basins (Easton et al., 1979; Nasser et al., 2006), which are the only readily available designs the authors could find. A photograph of the Dewitt Canyon Debris Basin in L.A. County, which was designed using the procedures outlined by Easton et al. (1979) and Nasser et al. (2006), is shown in Figure 2. The main components of these basins are an earthen berm, a debris barrier, a spillway, and an outlet works, the general layout of which is shown in Figure 3. The published design procedures for each of these components are presented in upcoming sections. A predicted debris-flow volume is the primary event characteristic used for sizing and siting the basin. L.A. County's current method of estimating debris-flow volume is presented in the next section.

#### Predicted Debris-Flow Volume

L.A. County design manuals specify that a debris-flow basin is to have a capacity equal to the Design Debris Event (DDE), which is the "quantity of sediment produced by a saturated watershed significantly recovered from a burn (after four years) as a result of a 50-year, 24-hour rainfall amount" (Nasser et al., 2006). The DDE is estimated from the area of a drainage basin area and its Debris Production curve. L.A. County is divided into 11 different Debris Production Areas (DPAs) based on local geologic, topographic, vegetative, and rainfall characteristics; these different DPAs are mapped in Appendix A of Nasser et al. (2006). Each DPA has an associated

Debris Production curve; an example of the Debris Production curves for the Los Angeles Basin is shown on Figure 4.

In the simplest case of an undeveloped basin, the predicted debris-flow volume is equal to the drainage area multiplied by the Debris Production rate for the appropriate DPA. Nasser et al. (2006) provide additional equations to obtain weighted-average predicted volumes for drainage basins that are partially developed, fall within multiple DPAs, or contain existing sediment control structures.

#### Basin Siting and Sizing

Nasser et al. (2006) provide an iterative technique through which the required height and location of the berm of a debris basin can be identified, based on the predicted debris-flow volume. This procedure is in agreement with other design recommendations (Hung et al., 1987; VanDine, 1996; and Deganutti et al., 2003), and thus will not be discussed further.

#### Debris Berm Specifications

Easton et al. (1979) provide detailed specifications for the earthen berm of the debris basin. The berm is to have a crest width of 20 ft (6.1 m) and side slopes of 3:1 (horizontal:vertical). Steeper slopes are allowable if adequate stability is demonstrated when the berm is analyzed according to small-dam design criteria. The crest is specified to rise from the spillway walls to each abutment with a slope equal to 60 percent of the natural channel slope within the basin. The upstream face of the berm is to be protected by a 6-in. (15-cm) thick concrete slab with No. 5 rebar placed on 18-in. (46-cm) centers in both directions. The downstream face of the berm is specified to be seeded to protect against erosion. The horizontal length of the berm foundation should be sufficiently long to preclude piping.

#### Debris Barrier Specifications

Easton et al. (1979) specify that a debris barrier consisting of vertical members should be provided upstream of the spillway to prevent it from clogging with debris. The barrier is specified to be at least 6 ft (1.8 m) upstream of the spillway. The top of the barrier should be 1 ft (0.3 m) below the water surface elevation that would be required to pass the design water discharge through the spillway. At least 2 ft (0.6 m) of freeboard is required between this water surface elevation and the crest of the

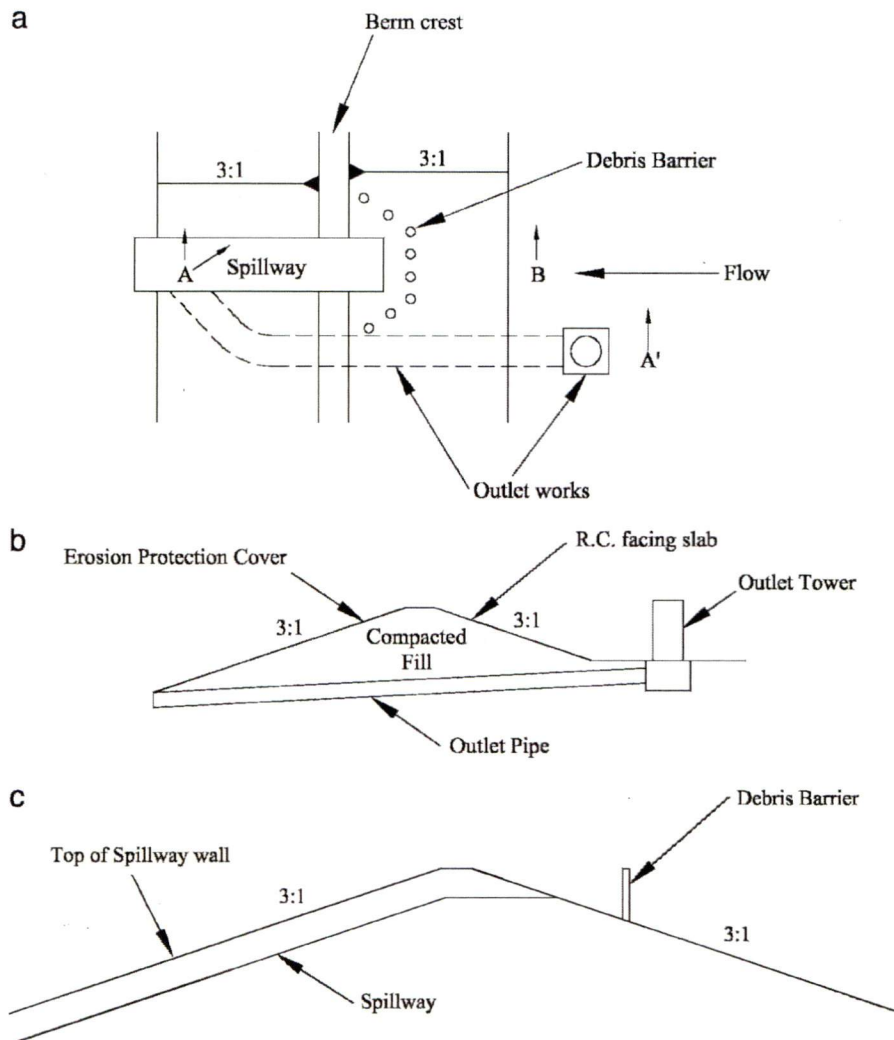

Figure 3. Layout of L.A. County's debris basin components (not to scale) (after Easton et al., 1979): (a) Plan view, (b) Section A-A', and (c) Section A-B.

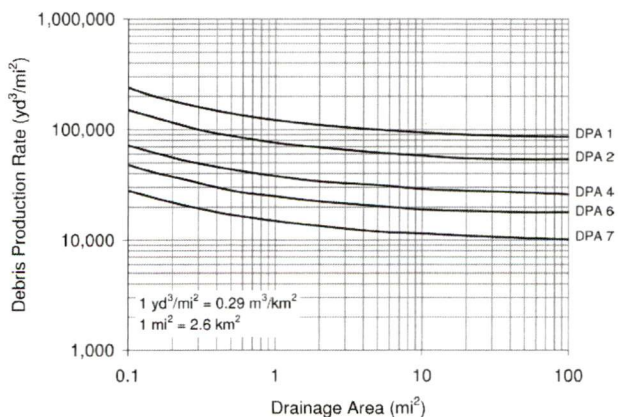

Figure 4. Debris Production curves for the DPAs within the Los Angeles Basin (after Nasser et al., 2006).

debris berm. Horizontal spacings between barrier members are specified to be less than the lesser of 4 ft (1.2 m) or two-thirds of the conduit width at the downstream end of the spillway. The barrier is specified to be designed for an equivalent fluid pressure of 62.5 lb/ft² (3.0 kPa) along its entire length (i.e., it is completely plugged). This load is assumed to be temporary, and thus the allowable stresses within the barrier members are increased by one-third. The depth of embedment of the barrier members is calculated as a function of the applied moment and the barrier diameter (Easton et al., 1979).

#### Spillway Specifications

Easton et al. (1979) provide specifications for the spillway capacity and also for the design of the

## Debris-Flow Mitigation Design

Table 1. *Freeboard and Factor of Safety recommendations (after FEMA, 1995).*

Type of Flooding	Freeboard (ft)	Impact Factor of Safety
Shallow water flooding, <1 ft	1	1.1
Moderate water flooding, <3 ft	1	1.2
Moderate water flooding, <3 ft with potential for debris, rocks <1 ft diameter and sediment	1	1.2
Mud floods, debris flooding <3 ft, minor surging and deposition, <1 ft boulders	2	1.25
Mud flows, debris flows <3 ft, surging, mud levees, >1 ft boulders, minor waves, deposition	2	1.4
Mud and debris flows >3 ft, surging, waves, boulders >3 ft, major deposition	3	1.5

Note: 1 ft = 0.3 m.

spillway walls and invert slab. This existing procedure designs the spillway for extreme flow events and is appropriate with respect to the Federal Emergency Management Agency's (FEMA's) (1995) freeboard recommendations (Table 1), and thus will not be discussed further.

### Outlet Works Specifications

Easton et al. (1979) specify that the outlet works should consist of an outlet tower and an outlet pipe capable of passing 150 ft<sup>3</sup>/s (4.2 m<sup>3</sup>/s) via non-pressurized flow. The outlet tower should be located at the lowest point of the basin (but not within the direct path of flow between the basin inlet and the spillway) and should extend at least 1 ft (0.3 m) above the predicted surface of deposited debris within the basin. The outlet pipe is to be at least 36 in. (91 cm) in diameter and should have a slope greater than five percent to prevent siltation. Easton et al. (1979) and L.A. County (2005) provide structural details for the standard outlet works design.

### Miscellaneous Specifications

Easton et al. (1979) provide requirements for engineering geology and subsurface investigations, and construction specifications and documentation. Detailed specifications are also given for access road grades and paving.

Structures designed using the methodology presented by Easton et al. (1979) and Nasseri et al. (2006) have been meeting the expectations of L.A. County. However, issues are arising related to hydromodification, stream degradation, and regulatory concerns related to preserving natural systems (Willardson, 2008).

### PROPOSED CHANGES TO THE STATE OF PRACTICE FOR DEBRIS-FLOW BASIN DESIGN

The intent of this paper is not to critique the design procedures published by L.A. County

(Easton et al., 1979; Nasseri et al., 2006), as these publications represent a great step forward in debris-flow mitigation engineering. However, as some of the only publications containing detailed design information, they serve as a representation of the state of practice in general and can be used as a springboard for discussion. The observations that follow should be taken as comments on the state of practice in a newly developing field and not as critiques of the pioneering work done by L.A. County. The following sections comment on potential changes to debris-basin design procedures when viewed in the context of debris-flow design recommendations presented within the technical literature. These suggestions particularly address the mitigation of fire-related debris flows and the adaptation of the design methodologies to regions beyond those used in their development. The following suggested changes to the prediction of debris-flow volume and prioritization of mitigation efforts are specific to fire-related debris flows, whereas the remaining suggestions are also applicable to non-fire-related debris flows.

### Predicted Debris-Flow Volume

A predicted debris-flow volume is a rational basis for basin design, since volume will dictate the capacity of the structure and is also a good indicator of the event hazard (Jakob, 2005; Cannon, 2007). Although Nasseri et al. (2006) acknowledge that recently burned drainage basins have higher sediment production (i.e., debris-flow volumes) than unburned basins, the Debris Production curves from which a DDE is estimated are based only on sediment production from unburned drainage basins (Nasseri et al., 2006).

In areas susceptible to wildfires, the expected debris-flow volume from a recently burned watershed should also be considered. Even if a debris basin is being designed below an unburned drainage basin, it would be prudent to consider the debris-flow volume that could result if the drainage burned. Two empirical methods for the estimation of post-wildfire debris-flow volumes are discussed below.

The Los Angeles District of the U.S. Army Corps of Engineers has developed empirical relationships for the estimation of debris production from recently burned, coastal-draining, mountainous, Southern California drainage basins (Gatwood et al., 2000). For drainage basins between 0.1 mi<sup>2</sup> and 3.0 mi<sup>2</sup> (0.3 to 7.8 km<sup>2</sup>) in area, the debris production may be estimated by:

$$\log Dy = 0.65(\log P) + 0.62(\log RR) + 0.18(\log A) + 0.12(FF) \quad (1)$$

where  $Dy$  = debris yield (yd<sup>3</sup>/mi<sup>2</sup>),  $P$  = maximum 1-hour precipitation (hundredths of an in.),  $RR$  = drainage basin relief ratio (ft/mi),  $A$  = drainage basin area (acres), and  $FF$  = non-dimensional Fire Factor (discussed below). Note that 1 yd<sup>3</sup>/mi<sup>2</sup> = 0.29 m<sup>3</sup>/km<sup>2</sup>; 0.01 in. = 0.25 mm; 1 ft/mi = 0.19 m/km; and 1 acre = 0.004 km<sup>2</sup>.

Eq. 1 was developed from nearly 350 observations and has a coefficient of determination of 0.99. For drainage basins less than 10 mi<sup>2</sup> (26 km<sup>2</sup>) in area for which peak flow data are available, the debris production may be estimated by (Gatwood et al., 2000):

$$\log Dy = 0.85(\log Q) + 0.53(\log RR) + 0.04(\log A) + 0.22(FF) \quad (2)$$

where  $Q$  = unit peak flow (ft<sup>3</sup>/s/mi<sup>2</sup>) (1 ft<sup>3</sup>/s/mi<sup>2</sup> = 0.01 m<sup>3</sup>/s/km<sup>2</sup>) and all other variables are as defined in Eq. 1.

The Fire Factor used in Eq. 1 and 2 is different from the Fire Factor used in other L.A. County analyses (e.g., Willardson and Walden, 2003). Fire Factors used by the U.S. Army Corps of Engineers for debris production estimates range from 3.0 for unburned or fully recovered watersheds to 6.5 for watersheds that recently have been completely burned (100-percent wildfire). These Fire Factors can be estimated as a function of watershed size and time since a 100-percent burn by using Figures 5 or 6. For drainage basins that are only partially burned, a weighted average of the Fire Factor is obtained based on the percentage of the basin that has been burned and the time since the burn(s), as presented in Appendix A of Gatwood et al. (2000).

Gartner et al. (2007) developed empirical models to predict debris-flow volumes from recently burned drainage basins in the western United States. The best model obtained from 50 debris-flow events in Colorado, Utah, and California was



Figure 5. Fire Factor curve for watersheds between 0.1 and 3.0 mi<sup>2</sup> (0.26 and 7.8 km<sup>2</sup>) (after Gatwood et al., 2000).

$$\ln V = 0.59(\ln S_{30}) + 0.65(B)^{1/2} + 0.18(R)^{1/2} + 7.21 \quad (3)$$

where  $V$  = debris-flow volume (m<sup>3</sup>),  $S_{30}$  = basin area with slopes greater than or equal to 30 percent (km<sup>2</sup>),  $B$  = basin area burned at moderate and high severity (km<sup>2</sup>), and  $R$  = total storm rainfall (mm).

Eq. 3 has a coefficient of determination of 0.83 and a residual standard error of 0.79 ln m<sup>3</sup> (Gartner et al., 2007).

For coastal Southern California drainages, the larger of the volumes obtained from the Corps of Engineers method (Gatwood et al., 2000) (Eq. 1 or 2) and the method of Gartner et al. (2007) (Eq. 3) could be used for design. The Corps of Engineers method will likely produce more accurate results within this region because these equations have higher coefficients of determination and are based on more observations than the method of Gartner et al. (2007). When applying the Corps of Engineers methods, it would be prudent to use a conservative Fire Factor to estimate volume, because a drainage basin may potentially become more extensively burned than its current condition. The development of Eq. 3 included debris-flow events from the Rocky Mountains, and thus this model would be more broadly applicable to regions outside of Southern California. Gartner et al. (2007) also consider burn severity in their volume prediction model and provide an estimate of modeling error.

#### Debris Berm Specifications

A berm crest that slopes toward the spillway is in agreement with other debris-flow basin design recommendations (Hungry et al., 1987). This will encourage any overflow to pass through the spillway

## Debris-Flow Mitigation Design

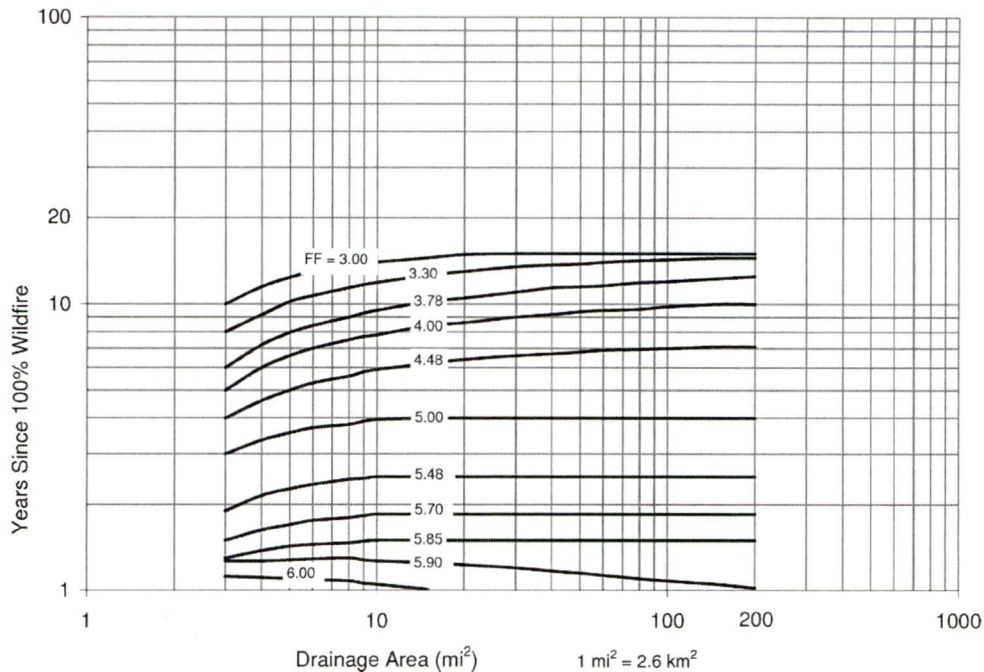

Figure 6. Fire Factor curves for watersheds between 3.0 and 200 mi<sup>2</sup> (7.8 and 520 km<sup>2</sup>) (after Gatwood et al., 2000).

rather than to overtop the dam, which will help to protect the berm from scour.

The recommended upstream slope of 3:1 (horizontal:vertical) may be overly conservative, given the low heights to which many debris basins will be constructed. Upstream slope stability is also aided by the specified reinforced concrete slab. A steeper upstream slope would require less fill placement during construction and would also result in greater basin capacity. Nasseri et al. (2006) report that several debris basins have experienced momentum overflow (i.e., overtopping) of the structure before the basins were filled. A steeper upstream slope may help to alleviate this problem as well.

Because laboratory soil strength testing is already required by Section B of Easton et al. (1979), it would not be overly difficult to conduct slope stability analyses. Instead of relying on a blanket specification for a 3:1 slope, the steepest upstream slope that satisfies all of the design criteria could be used.

The phenomenon that Nasseri et al. (2006) refer to as “momentum overflow” is better known in the debris-flow literature as runup. Runup is the ability of a debris flow to climb an adverse slope due to its momentum. If the runup height of a debris flow exceeds the berm height, overtopping is predicted to occur. Once a debris basin has been sized following the procedures outlined above, it should be checked that the berm is sufficiently high to resist debris-flow runup.

A commonly advocated runup prediction method (Hung et al., 1984; Hung and McClung, 1987; VanDine, 1996; and Lo, 2000) that has accurately matched laboratory experiments (Chu et al., 1995) is the leading-edge model:

$$\Delta h = \frac{v^2 \cos^2(\theta_0 + \theta) \tan \theta}{g(S_f + \tan \theta)} \left( 1 + \frac{gh \cos \theta_0}{2v^2} \right)^2 \quad (4)$$

where:  $\Delta h$  = runup height,  $v$  = debris-flow velocity,  $\theta_0$  = approach slope angle,  $\theta$  = runup slope angle (berm slope),  $g$  = acceleration of gravity,  $S_f$  = friction slope, and  $h$  = debris-flow depth, all in consistent units.

For runup estimations, the friction slope ( $S_f$ ) may be adequately estimated as 1.1 times the tangent of the alluvial fan slope (Rickenmann, 2005). Prochaska et al. (2008b) discuss a new method for the estimation of debris-flow velocity and the maximum probable debris-flow depth, which can be used in Eq. 4. A maximum possible flow depth,  $h$ , may be estimated as the height from bedrock to the top of the channel banks. This estimate conservatively assumes that, during a debris flow, the channel has been scoured down to bedrock and the channel is flowing full. An increase in flow depth above the height of the channel banks will cause material to spill over and deposit due to lack of confinement, effectively limiting the maximum potential flow depth. A debris flow velocity can be predicted preliminarily from the flow depth ( $h$ )

Table 2. Summary of velocity versus  $h^2S$  data (from Prochaska et al., 2008b).

	$h^2S < 3 \text{ m}^2$	$3 \text{ m}^2 < h^2S < 6 \text{ m}^2$	$6 \text{ m}^2 < h^2S$
Mean - 1 standard deviation	3.7 m/s	4.5 m/s	7.0 m/s
Mean	6.0 m/s	6.8 m/s	10.4 m/s
Mean + 1 standard deviation	8.3 m/s	9.1 m/s	13.8 m/s
Mean + 2 standard deviations	10.6 m/s	11.4 m/s	17.2 m/s

and the sine of the channel angle ( $S$ ) using Table 2. This table was developed from a statistical analysis of 30 debris-flow events from the technical literature (Prochaska et al., 2008b).

No debris-berm freeboard heights are recommended by Easton et al. (1979) or Nasser et al. (2006). Given the inherent uncertainties with debris-flow volume estimations and flow mechanics, it would seem prudent to provide an additional factor of safety to the basin capacity through a minimum freeboard requirement.

FEMA provides recommended freeboard heights for various categories of floods (Table 1) (FEMA, 1995). From Table 1, a required freeboard of at least 3 ft (0.9 m) should be provided above either the spillway elevation of the debris berm or the predicted height of runoff (Eq. 4), whichever is higher. This freeboard height is comparable to those used in previous designs (Nasmith and Mercer, 1979; VanDine, 1996).

#### Debris Barrier Specifications

The design of the debris barrier appears to only consider the loading from water and not the impact from any debris, which is unconservative. Also, the recommended barrier spacing does not account for the site-specific debris gradation.

The debris barrier should be designed to withstand loading from the retained debris. Debris impact loads can either be estimated analytically through the loss of momentum or empirically related to hydrostatic forces. A commonly advocated analytical equation for the estimation of impact force is (Hung et al., 1984; VanDine, 1996; and Lo, 2000):

$$F_d = h * \rho * v^2 * \sin \delta \tag{5}$$

where  $F$  = debris impact force per unit width of analysis,  $h$  = debris-flow depth,  $\rho$  = debris density,  $v$  = debris-flow velocity, and  $\delta$  = acute angle between flow velocity vector and impacted surface, all in consistent units.

Eq. 5 assumes that the debris has zero strength. Field instrumentation and laboratory simulation of debris-flow impacts have shown that actual forces

can be much larger than those predicted by Eq. 5 because of the shear strength of debris and reflection waves occurring upon impact (Lin et al., 1997; Lo, 2000). Figure 7 shows a histogram of field-measured impact forces normalized by the impact forces calculated by Eq. 5 for 24 debris-flow measurements from China (Lo, 2000). The data summarized on Figure 7 have a mean of 3.0 and a standard deviation of 1.3. Lo (2000) recommends multiplying Eq. 5 by a factor of three to obtain a design impact force.

The debris impact force can also be empirically estimated by factoring a hydrostatic load (Lo, 2000):

$$F_d = \frac{\chi * \gamma_w * h^2}{2} \tag{6}$$

where  $F_d$  = debris impact force per unit width of analysis,  $\chi$  = load factor,  $\gamma_w$  = unit weight of water, and  $h$  = debris-flow depth, all in consistent units.

The load factor ( $\chi$ ) in Eq. 6 has been recommended as being between approximately three and five (Scotton and Deganutti, 1997; Lo, 2000). Hollingsworth and Kovacs (1981) advise using an equivalent unit weight of 125 lb/ft<sup>3</sup> (19.7 kN/m<sup>3</sup>) for debris loads, which would make  $\chi$  equal to two. Because of this range of suggested load factor values, a conservative load factor toward the high end of the presented ranges should be used. The flow velocity

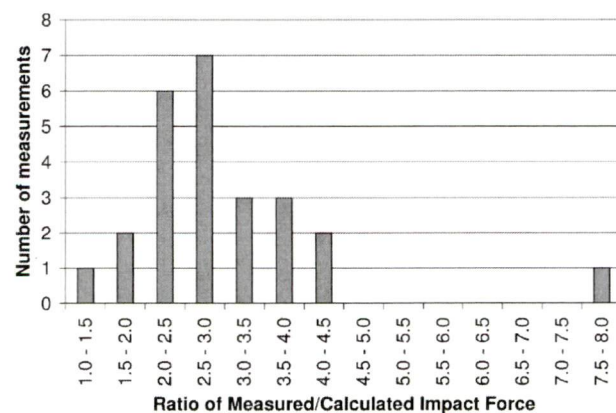

Figure 7. Histogram of the ratios of field-measured impact forces to impact forces calculated by Eq. 5 (data are from Lo, 2000).

and depth required for debris impact force equations (Eq. 5 and 6) can be estimated as presented in Table 2 and discussed by Prochaska et al. (2008b).

In addition to debris impact forces, the debris barrier should also be designed to withstand boulder impact forces. For cantilever steel members in a debris barrier, the flexural stiffness equation would be most appropriate (Hung et al., 1984; Johnson and McCuen, 1992; and Lo, 2000):

$$F = v_b \sin \beta \sqrt{m_b K_B} \quad (7a)$$

$$K_B = \frac{3EI}{(\Psi L_B)^3} \quad \text{for a cantilever beam or wall} \quad (7b)$$

where  $F$  = impact force (MN),  $v_b$  = boulder velocity (m/s),  $\beta$  = acute angle between the velocity vector and the barrier surface,  $m_b$  = boulder mass (Mg),  $EI$  = bending stiffness of barrier (GPa\*m<sup>4</sup>),  $L_B$  = length or height of barrier (m), and  $\Psi$  = ratio of distance between the impact location and barrier support to the length of the barrier.

The boulder velocity for use in Eq. 7 should be equal to the predicted debris-flow velocity, and the size of the design boulder should be based on the available sizes of transportable material (Hung et al., 1984; Lo, 2000). Once the maximum impact force from Eq. 5, 6, and 7 is decided upon for design, this load should be increased by a factor of safety of 1.5 (Table 1).

Consideration of the site-specific debris gradation can also be incorporated into the recommended barrier spacings. In Japan, barriers are typically spaced at 1.5 to 2 times the size of the largest boulders (VanDine, 1996; Miyazawa et al., 2003). Barrier spacings used in model tests also fall within this range (Chen and Ho, 1997). This requirement could be added to the barrier spacing specifications presented previously. Channel-specific maximum particle sizes could be estimated through investigations of the sizes of material present within the channel and source areas, and also the sizes of boulders previously deposited on the fan. This evaluation of maximum particle size is also required for the estimation of boulder impact forces (Eq. 7).

#### Outlet Works Specifications

Easton et al. (1979) and L.A. County (2005) provide one standard outlet works design for all constructed basins, and it may be more practical to provide a few different standard designs from which to choose. Specifically, different designs should address the ability of the outlet works to convey different levels of flow and the resistance of the outlet tower to various magnitudes of impact forces.

Because Easton et al. (1979) specify that the debris barrier should be designed for loads from only clear water flow, it is likely that the standard design for the outlet tower also does not consider debris-flow impact forces. It should be verified that the existing or any future design has an appropriate factor of safety (Table 1) against the debris impact forces predicted by Eq. 5 and 6 and the boulder impact forces predicted by Eq. 7.

Different outlet works designs should be developed for different expected impact forces. The existing standard design (L.A. County, 2005) could be used as a generic template, with specific dimensions and notes obtainable from a table based on the expected flow depth, velocity, and boulder sizes. Each design should provide a factor of safety of at least 1.5 against the expected forces (Table 1). These different designs could also provide various flow capacities within the range of discharges observed from the region's debris-flow-producing drainage basins.

#### Miscellaneous Specifications

An important aspect of apportioning emergency mitigation efforts is the likelihood of an individual basin to produce a debris flow. Cannon (2001) found that debris flows were not the prevalent response for 95 recently burned drainage basins in Colorado, New Mexico, and California. Only approximately 40 percent of these basins produced debris flows as their initial erosive response, and only one basin produced a debris flow in a subsequent erosional event (Cannon, 2001). Thus, in order to efficiently allocate mitigation funds, the likelihood of individual drainage basins to produce debris flows should be estimated, along with the associated hazard and risk in the event that a debris flow does occur.

The U.S. Geological Survey has developed an empirical relationship to estimate the probability of fire-related debris-flow occurrence from individual basins (Cannon et al., 2003; 2004a; 2004b):

$$P = \frac{e^x}{1 + e^x} \quad (8a)$$

$$\begin{aligned} x = & -29.693 + 10.697(\%Burn) - 9.875(Sorting) \\ & + 0.208(I) + 5.729(\%Organics) - 0.957 \\ & (Permeability) + 9.351(Drainage) \quad (8b) \\ & + 2.864(\%GE30\%) - 8.335(\%Burn * \%Organics) \\ & + 4.669(Sorting * Drainage) - 0.174(\%GE30\% * I) \end{aligned}$$



Table 3. Summary of proposed changes to existing berm designs.

Design Aspect	State of Practice (Easton et al., 1979; Nasser et al., 2006)	Proposed Changes
Event volume	Sediment production from unburned drainage following 50-year, 24-hour rainfall	Consider sediment production from burned drainage basin
Berm slopes	3H:1V	Use steepest slopes that satisfy all design criteria
Runup height	Not specified	Design berm height for anticipated debris-flow runup
Berm freeboard	Not specified	Provide 3 ft (0.9 m) of freeboard as per FEMA (1995)
Debris barrier spacing	Lesser of 4 ft (1.2 m) or 2/3 of downstream conduit width	Base spacing on site-specific debris gradation
Debris barrier loading	Designed for water load	Consider loading from debris impacts and boulder impacts
Outlet works capacity	150 ft <sup>3</sup> /s (4.2 m <sup>3</sup> /s)	Provide various designs to accommodate site-specific streamflow
Outlet works loading	Not specified	Consider loading from debris impacts and boulder impacts
Mitigation apportioning	Not specified	Consider debris-flow probability and associated hazards and risk to allocate mitigation funds

where  $P$  = probability of debris-flow occurrence, %*Burn* = percent of the basin burned at high and moderate severities, *Sorting* = sorting of the burned soil grain-size distribution (Inman, 1952),  $I$  = average storm rainfall intensity (mm/hr), %*Organics* = percent of soil organic matter, *Permeability* = soil permeability (in./hr) (Schwartz and Alexander, 1995), *Drainage* = soil drainage (Schwartz and Alexander, 1995), and %*GE30%* = percent of the basin with slopes greater than or equal to 30 percent. Note: 1 in./hr = 25.4 mm/hr.

The debris-flow hazard for an individual basin can be estimated from its predicted volume and expected runout distance or inundation area. A predicted fire-related debris-flow volume can be estimated from Eq. 3. Runout or inundated area can be estimated from the ACS model (Prochaska et al., 2008a), from other existing runout estimation methods discussed by Prochaska et al. (2008a), or from developing models specific to fire-related debris flows (i.e., Bernard, 2007). Once a hazardous area has been delineated, the associated risk can be estimated from the value of the property within it. This value should consider the amount and types of development, the presence of human occupancy, and the importance of transportation corridors. Debris-flow consequence can then be estimated and ranked by multiplying each basin's risk by its probability of debris-flow occurrence (Eq. 8).

Table 3 summarizes the proposed changes to the state of practice for debris-flow basin design, as presented by Easton et al. (1979) and Nasser et al. (2006). These changes will likely result in increased mitigation costs, the amount of which will be site-specific. The additional cost would likely be offset by

the higher safety provided by the increased mitigation effectiveness.

#### STATE OF PRACTICE FOR DEBRIS-FLOW DEFLECTION BERM DESIGN

##### Oregon Department of Forestry Deflection Berm Design

The Oregon Department of Forestry has overseen the construction of deflection berms to mitigate debris-flow hazards below logged watersheds. Rather than performing detailed analyses, qualitative judgment is conservatively applied to develop an "over-engineered" design. The berms are constructed at low angles (with respect to the natural flow path), oversized, and armored with large rocks to avoid the issues of calculating runup and impact forces (Hinkle, 2007). Deflection berms designed using this methodology have not yet been tested by debris-flow events (Hinkle, 2008).

##### NRCS Deflection Berm Design

The NRCS office in Provo, Utah, has recently designed deflection berms for the mitigation of fire-related debris flows from Buckley Draw in Provo and Tributary 4 in Santaquin (McDonald and Giraud, 2002). Figure 8 shows a downstream view of the Buckley Draw deflection berm near Provo, Utah, following a small debris flow.

To size the deflection berms, the Provo NRCS first estimated the peak clear-water discharge from each basin using conventional hydrological methods (e.g., Brutsaert, 2005). The 25-year, 24-hour precipitation



Figure 8. Downstream view of the Buckley Draw deflection berm near Provo, Utah, after a small debris flow (from Elliot, 2007).

was used for the design of the Buckley Draw deflection berm. A bulking factor was then applied to the clear-water discharge to account for the debris-flow peak discharge. For Buckley Draw, a bulking factor of approximately 1.4 was used. This bulking factor was estimated using an unpublished Engineering Technical Note developed by the NRCS in New Mexico that discusses soil erodibility. Additional conservatism and freeboard were added to the berm height above that required to pass the design discharge. Superelevation heights were also considered, and the upstream side of the berm was armored with large rocks (Rogers, 2007).

Structures designed using this methodology have settled out coarse material from debris flows, with only water and some fines exiting the structure (Rogers, 2008).

#### PROPOSED CHANGES TO THE STATE OF PRACTICE FOR DEBRIS-FLOW DEFLECTION BERM DESIGN

As with the critique of debris-flow basin design, the few published designs for debris-flow deflection berms are assumed to represent the state of practice in general. These published designs represent the forefront of a field that is newly developing, and the comments below are aimed at improving the state of practice and not at disparaging these designs.

#### Discussion

Because Oregon's Department of Forestry policy of developing conservative deflection berm designs from qualitative judgment is, by definition, subjective, it may be difficult to assess exactly what constitutes a conservative design. In order to deem a design conservative, one must have an idea of the berm size that is required to provide debris-flow control. This knowledge may come from the precedent of the successes or failures of previous structures or from a quantitative estimate of the characteristics of a design debris-flow event. Upcoming sections provide a methodology for the quantitative design of debris-flow deflection berms.

Although the NRCS designs deflection berms for a quantitative discharge, the reliance on an erodibility study from New Mexico introduces some variability. First, the applicability of this study to Utah is difficult to prove because of possible geologic, meteorologic, and vegetative differences between the two states. Second, it is uncertain whether the New Mexico erodibility study considered scouring effects of debris flows or if it was only applicable to the bulking of sediment into normal stream flow. Bulking rates observed once debris flows occur will be higher than those associated with clear-water flow due to the increased shear stress caused by a higher fluid density (Hung et al., 2005).

L.A. County has developed bulking factors to estimate bulked discharge from water discharge (Nasseri et al., 2006), which also introduces imprecision. The same bulking factor is applied to both burned and unburned drainage basins, when in reality a much higher sediment yield should be expected from burned drainages (Cannon and Gartner, 2005).

As discussed in the next section, a simpler method for specifying the flow capacity of a deflection berm would be to ensure that it is capable of passing at least as much flow as the channel immediately upstream from it.

### Proposed Guidelines

This section presents proposed guidelines for the design of debris-flow deflection berms. These guidelines would be applicable to both fire-related debris flows and non-fire-related debris flows. Deflection structures may consist of either earthen berms or structural walls (Mears, 1981), depending on material availability. This section focuses on the design of earthen deflection berms.

#### Berm Siting and Alignment

The primary consideration for the design of deflection berms is the siting and alignment of the structure. Deflection berms will be most effective when they are located high on alluvial fans. Debris flows here will have higher velocities than at locations lower on fans; these higher velocities will encourage debris to pass through the deflection berm rather than depositing within it and reducing the effective height of the structure (Mears, 1981). Siting deflection berms higher on alluvial fans also enables more area to be protected, and placing a berm closer to the mountain channel lessens the chance that a debris flow could avulse and bypass the structure. However, in some cases high debris-flow velocities at the mouths of channels may make mitigation too difficult (Nasmith and Mercer, 1979), and thus berms would have to be placed lower on the fan to allow the debris flow to decelerate.

Deflection-berm alignments can be straight, curved, or a combination of the two (Mears, 1981). The siting and alignment of individual deflections berms will vary based on several site-specific considerations, including:

- The natural alignment of the stream course, and the drainage characteristics of the area.
- The topography of the alluvial fan.
- The location of the areas to be protected.

- The location of low-risk areas to where the debris can be directed.
- The anticipated characteristics of the design debris-flow event.

When designing the alignment of the berm, specific attention must be paid to where the debris flow and normal streamflow are to be directed. Consideration must be made of how the debris-flow hazard and risk to the surrounding area will change due to the deflection of the natural debris path. The deflection of the debris flow may decrease or increase its runout length and inundation area, depending on site-specific characteristics. VanDine (1996) reported that deflection berms can be aligned at low gradients to encourage deposition and reduce the runout length of debris flows. However, deflection berms may instead provide additional confinement to flowing debris and thus increase the runout length (Mears, 1981). If the deflection structure is contiguous with the mountain front and normal streamflow will be contained behind the berm, then provisions must also be made to safely direct this flow back into a natural drainage.

#### Berm Height Sizing

After the location and alignment of the deflection berm is decided upon, it must be appropriately sized. The berm should be high enough to pass the discharge from the design debris-flow event, with consideration given to superelevation and runup heights and an appropriate freeboard, or

$$h_B = h + \Delta h + 3 \text{ ft} \quad (9)$$

where  $h_B$  = height of debris-flow deflection berm,  $h$  = depth of flow,  $\Delta h$  = superelevation (Eq. 10) or runup (Eq. 4), and 3 ft = debris-flow freeboard recommended by FEMA (Table 1) (0.9 m).

The superelevation height in Eq. 9 refers to the difference in surface elevation, or banking, of a debris flow as it travels around a bend. Higher velocities result in increased banking. The most commonly referenced method for making this estimation is the forced vortex equation (Eq. 10) (Johnson, 1984). A more detailed discussion of the relationship between superelevation and velocity is presented by Prochaska et al. (2008b).

$$\Delta h = \frac{v^2 b}{R_c g} \quad (10)$$

where  $\Delta h$  = superelevation height,  $v$  = mean flow velocity,  $b$  = the flow width,  $R_c$  = radius of curvature

of the channel, and  $g$  = acceleration of gravity, all in consistent units.

Two implicit assumptions must be met for Eq. 9 to be conservative with respect to continuity of flow ( $Q = vA$ ): (1) the cross-sectional area of flow behind the deflection berm is at least as large as that in the natural channel upstream of the berm and (2) the flow velocity behind the berm is similar to that in the channel upstream of the berm.

Eq. 9 assumes that the effective height of the berm is not reduced due to debris-flow deposition behind it. If deposited material is not removed from behind the berm after each debris flow, the design height of the berm should be increased by the expected depth of deposition in order to maintain adequate freeboard. The decision whether to construct a higher berm or to specify timely removal of deposited material will depend on characteristics of the debris-flow processes (frequency and magnitude of events), site considerations (e.g., material availability and ease of access), and anthropogenic factors (e.g., the responsibility of the agency managing the berm).

As discussed by Prochaska et al. (2008b), the height of the channel banks will effectively limit the maximum debris-flow depth and thus will provide a conservative estimate of  $h$  for use in Eq. 9. For curved berm alignments, the value of  $\Delta h$  can be obtained from Eq. 10 using a velocity predicted from Table 2 or by other methods discussed by Prochaska et al. (2008b). Use of Eq. 10 in this setting will not encounter the difficulties with the estimation of  $R_c$  that are discussed by Prochaska et al. (2008b), because the berm alignment will be an engineered curve rather than a natural channel bend. For straight berm alignments,  $\Delta h$  should be obtained from Eq. 4 following the guidelines presented above. In the case of flowing debris striking an obliquely oriented runup slope, the velocity ( $v$ ) used in Eq. 4 should be the slope-normal component of velocity (Mears, 1981), that is the flow velocity multiplied by  $\sin \delta$  (as defined in Eq. 5).

If flow past the deflection berm is supercritical and cross-wave maxima occur at the outer bank, the superelevation in Eq. 9 ( $\Delta h$ ) could be double that predicted by Eq. 10 (Pierson, 1985). Unfortunately, it is not currently possible to predict the locations where maximum cross-wave heights will occur (Iverson, 2005). It is also not possible to design the berm to preclude supercritical flow, as cross waves that might develop higher in the natural channel are still able to continue far downstream (Chow, 1959). Thus, the deflection berm may become overtopped if maximum cross-wave heights occur on the outer bank of the bend.

Given the uncertainty in the presence and location of cross-wave interferences, it may be uneconomical

to design the berm height for these sporadic increases in superelevations. If space allows, a more economical option would be to construct a second berm downslope of and parallel to the main deflection berm (e.g., Nasmith and Mercer, 1979). For berms with similar top widths and side slopes, the construction of two smaller berms with heights  $h_1$  and  $h_2$  will always require less fill placement than a single berm with a height of  $h_1 + h_2$ . This second berm would provide additional security against overtopping of the first berm from cross-wave amplification or from reduced freeboard caused by the failure to remove deposited material.

### Berm Cross Section

The top of the berm should be at least 10 ft (3 m) wide if it is to be used for maintenance and cleanout access (Sherard et al., 1963). A narrower top width may be used if maintenance and cleanout access is provided from behind the berm rather than from on top of it, but narrower widths will make placement and compaction of the fill near the berm crest more difficult (Fell et al., 2005).

The side slopes of a deflection berm should be sufficiently stable against all anticipated loading conditions, and steeper slopes will help to lessen the effects of runup (Eq. 4). Previous designs have used berm slopes as steep as 1.5:1 (horizontal:vertical) (Martin et al., 1984; VanDine, 1996). In Colorado a deflection berm may be classified as a Diversion Dam, and the berm slopes must conform to a minimum acceptable factor of safety of 1.3 (State of Colorado, 2007).

Earthen berms are well suited to withstand impact forces due to their large mass (Mears, 1981). To account for the impact of a debris flow, a lateral force equal to the estimated debris impact force (Eq. 5 and 6) can be applied to the upslope face of the berm during analysis of the downstream face stability. Stability of the berm against bearing capacity failure and sliding on its foundation due to the impact load should also be checked, with resulting factors of safety of at least 3 and 1.5, respectively (Das, 1999).

The downstream face of the deflection berm should be vegetated or otherwise protected to prevent erosion. The upslope face of the berm should be armored to protect it against debris-flow scour. Given the likelihood of a supply of boulders already on the debris fan, riprap may be the most economical choice for slope armoring. Riprap used to protect embankment dam slopes against wave action is sized so that it is large enough to dissipate the wave energy without being displaced (Fell et al., 2005), but if this same

Table 4. Recommended riprap sizes for slope protection (after Sherard et al., 1963).

Maximum Debris-Flow Depth (ft)	Recommended Riprap Size (in.)
<4	24
4 to 8	36
>8	48

Notes: 1 ft = 0.3 m and 1 in. = 2.5 cm.

criterion was applied to debris-flow slope protection the resulting particle sizes would become prohibitively large. Recommendations from Sherard et al. (1963) have been modified for debris-flow slope protection, as shown in Table 4. These riprap sizes are comparable to sizes that have been used previously to armor deflection berms (Martin et al., 1984).

The wave heights tabulated by Sherard et al. (1963) have been replaced by an expected maximum debris-flow depth in Table 4. The recommended riprap sizes in Table 4 are approximately twice as large as those presented by Sherard et al. (1963), since doubling the riprap size will result in an eight-fold increase in its resistive mass, and the load factors discussed with Eq. 5 and 6 (see also Figure 7) indicate that debris-flow impact forces can be up to eight times as large as the associated hydrostatic impacts. Because debris flows of the sizes listed in Table 4 have the capability of transporting the associated recommended riprap sizes, the riprap should be grouted or otherwise securely keyed into the berm.

The channel behind the berm should be sized to convey a range of debris flows that may be smaller than the design event; a trapezoidal channel is the best geometry for accomplishing this (Hungr et al., 1984). In order to prevent deposition of debris, the channel must provide an adequate slope and confinement. Hungr et al. (1984) report that in British Columbia deposition of channelized debris

flows occurs on slopes less than 8–12 degrees. This range is in agreement with deposition-inducing slopes found in other regions (e.g., California [Campbell, 1975] and Japan [Ikeya, 1981]). Hungr et al. (1984) also recommend that the debris flow depth-to-width ratio should be greater than 0.2 to prevent deposition. Fannin and Rollerson (1993) suggest that in British Columbia deposition is more likely to occur if the channel width-to-slope ratio (meters per degree) is greater than one. While these location-specific observations should be calibrated to local conditions, they do provide items for consideration and starting values from which to base preliminary designs.

When designing the berm and the final configuration of the associated channel, it will often be advantageous to balance the volume of cut and fill so that additional soil does not need to be imported to the site. If the constructed channel is located within an earthen cut, it should be ensured that positive drainage is maintained downstream.

A generalized cross section depicting the deflection berm components is shown on Figure 9.

### SUMMARY AND CONCLUSIONS

The state of practice for the design of debris-flow basins and berms has been reviewed. Published manuals for the design of debris-flow basins could be improved by incorporating the following elements:

- The expected debris-flow volumes from recently burned drainage basins should be considered when sizing a basin.
- Debris-flow runup height and FEMA’s (1995) recommended freeboard should be considered when designing the upstream slope and height of the berm.
- The debris barrier should be designed to withstand impact loadings from debris and boulders rather than from just clear-water flow.

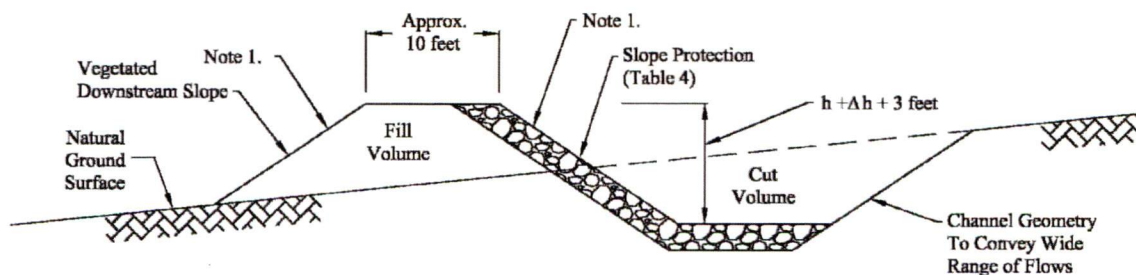

Note 1. Grade slopes to provide safety factor > 1.3.

Figure 9. Generalized deflection berm cross section.

- It should be verified that the outlet tower is capable of withstanding impact forces from debris and boulders.

Debris-flow deflection berms have been conservatively designed using qualitative judgment, but the degree of conservatism cannot be determined. Simple guidelines have been presented for the design of deflection berms, which include:

- Peak discharge
- Berm alignment and height
- Berm top width and side slopes
- Stability under impact loading and slope protection
- The ability to pass a range of flow rates

Although the final design of a deflection berm will be largely dictated by site-specific geometries, items to consider while aligning the berm have been presented, and the above guidelines can be used as an aid while designing representative berm sections.

#### ACKNOWLEDGMENTS

This work has been funded by a U.S. Department of Education Graduate Assistance in Areas of National Need (GAANN) Fellowship (award #P200A060133). Thanks to Ben Willardson (L.A. County Flood Control-Water Resources Division), Jason Hinkle (Oregon Department of Forestry), and Steve Rogers (Provo, Utah NRCS) for providing information about their design practices.

#### REFERENCES

- BERNARD, D., 2007, *Estimation of Inundation Areas of Post-Wildfire Debris Flows*: Unpublished M.S. Thesis, Department of Geology and Geological Engineering, Colorado School of Mines, Golden, CO, 77 p.
- BRADLEY, J. B.; RICHARDS, D. L.; AND BAHNER, C. D., 2005, *Debris Control Structures—Evaluation and Countermeasures. Hydraulic Engineering Circular 9*, 3rd ed.: Electronic document, available at <http://www.fhwa.dot.gov/engineering/hydraulics/pubs/04016/>
- BRUTSAERT, W., 2005, *Hydrology: An Introduction*: Cambridge University Press, Cambridge, MA, 605 p.
- CAMPBELL, R. H., 1975, *Soil Slips, Debris Flows, and Rainstorms in the Santa Monica Mountains and Vicinity, Southern California*: U.S. Geological Survey Professional Paper 851, 51 p.
- CANNON, S. H., 2001, Debris-flow generation from recently burned watersheds: *Environmental Engineering Geoscience*, Vol. VII, No. 4, pp. 321–341.
- CANNON, S. H., 2007, personal communication on 22 May, U.S. Geological Survey, Denver, CO.
- CANNON, S. H. AND GARTNER, J. E., 2005, Wildfire-related debris flow from a hazards perspective. In Jakob, M. and Hungr, O. (Editors), *Debris-Flow Hazards and Related Phenomena*: Praxis, Chichester, U.K., pp. 363–385.
- CANNON, S. H.; GARTNER, J. E.; RUPERT, M. G.; AND MICHAEL, J. A., 2004a, *Emergency Assessment of Debris-Flow Hazards from Basins Burned by the Cedar and Paradise Fires of 2003, Southern California*: U.S. Geological Survey Open-File Report 2004-1011, Electronic document, available at <http://pubs.usgs.gov/of/2004/1011/>
- CANNON, S. H.; GARTNER, J. E.; RUPERT, M. G.; AND MICHAEL, J. A., 2004b, *Emergency Assessment of Debris-Flow Hazards from Basins Burned by the Padua Fire of 2003, Southern California*: U.S. Geological Survey Open-File Report 2004-1072, Electronic document, available at <http://pubs.usgs.gov/of/2004/1072/>
- CANNON, S. H.; GARTNER, J. E.; RUPERT, M. G.; MICHAEL, J. A.; DJOKIC, D.; AND SREEDHAR, S., 2003, *Emergency Assessment of Debris-Flow Hazards from Basins Burned by the Grand Prix and Old Fires of 2003, Southern California*: U.S. Geological Survey Open-File Report 03-475, Electronic document, available at <http://pubs.usgs.gov/of/2003/ofr-03-475/>
- CHEN, R.-H. AND HO, M.-L., 1997, The effect of open dams on debris flows. In Chen, C.-l. (Editor), *Debris-Flow Hazards Mitigation: Mechanics, Prediction, and Assessment, Proceedings of the First International Conference*: ASCE, New York, pp. 626–635.
- CHOW, V. T., 1959, *Open-Channel Hydraulics*: McGraw-Hill Book Company, New York, 680 p.
- CHU, T.; HILL, G.; MCCLUNG, D. M.; NGUN, R.; AND SHERKAT, R., 1995, Experiments on granular flows to predict avalanche runoff: *Canadian Geotechnical Journal*, Vol. 32, pp. 285–295.
- DAS, B. M., 1999, *Principles of Foundation Engineering*, 4th ed.: PWS Publishing, Pacific Grove, CA, 862 p.
- DEGANUTTI, A. M.; TECCA, P. R.; GENEVOIS, R.; AND GALGARO, A., 2003, Field and laboratory study on the deposition features of a debris flow. In Rickenmann, D. and Chen, C.-l. (Editors), *Debris-Flow Hazards Mitigation: Mechanics, Prediction, and Assessment, Proceedings of the Third International Conference*: Millpress, Rotterdam, Netherlands, pp. 833–841.
- EASTON, J. L.; HALLSTROM, C. W.; AND SENZAKI, K., 1979, *Debris Dams and Basins Design Manual*: Los Angeles County Flood Control District, Electronic document, available at [http://ladpw.org/des/Design\\_Manuals/](http://ladpw.org/des/Design_Manuals/)
- ELLIOT, A., 2007, *Wildfires and Debris Flows in Northern Utah*: Utah Geological Survey Public Information Series 90, Electronic document, available at <http://geology.utah.gov/online/pi/pi-90.pdf>
- FANNIN, R. J. AND ROLLERSON, T. P., 1993, Debris flows: Some physical characteristics and behaviour: *Canadian Geotechnical Journal*, Vol. 30, pp. 71–81.
- FELL, R.; MACGREGOR, P.; STAPLEDON, D.; AND BELL, G., 2005, *Geotechnical Engineering of Dams*: A.A. Balkema, Leiden, Netherlands, 912 p.
- FEMA, 1995, *Engineering Principles and Practices for Retrofitting Flood Prone Residential Buildings*: FEMA 259, Federal Emergency Management Agency, Electronic document, available at <http://www.fema.gov/library/viewRecord.do?id=1645>
- FIEBIGER, G., 1997, Structures of debris flow countermeasures. In Chen, C.-l. (Editor), *Debris-Flow Hazards Mitigation: Mechanics, Prediction, and Assessment, Proceedings of the First International Conference*: ASCE, New York, pp. 596–605.
- GARTNER, J. E.; CANNON, S. H.; SANTI, P. M.; AND DEWOLFE, V. G., 2007, Empirical models to predict the volumes of debris flows generated by recently burned basins in the Western U.S.: *Geomorphology*, Vol. 96, pp. 310–321, doi: 10.1016/j.geomorph.2007.02.033.
- GATWOOD, E.; PEDERSEN, J.; AND CASEY, K., 2000, *Los Angeles District Method for Prediction of Debris Yield*: U.S. Army

- Corps of Engineers Los Angeles District Hydrology and Hydraulics Branch, Los Angeles, CA.
- GIRAUD, R. E., 2005, *Guidelines for the Geologic Evaluation of Debris-Flow Hazards on Alluvial Fans in Utah*: Utah Geological Survey Miscellaneous Publication 05-6, Electronic document, available at <http://geology.utah.gov/online/mp/mp05-06.pdf>
- GIRAUD, R. E. AND McDONALD, G. N., 2007, The 2000–2004 fire-related debris flows in northern Utah. In Schaefer, V. R.; Schuster, R. L.; and Turner, A. K. (Editors), *Conference Presentations, 1st North American Landslide Conference, Vail, Colorado*: AEG Special Publication No. 23, Association of Environmental and Engineering Geologists, Denver, CO, compact disk.
- HEUMADER, J., 2000, Technical debris-flow countermeasures in Austria—A review. In Wieczorek, G. F. and Naeser, N. D. (Editors), *Debris-Flow Hazards Mitigation: Mechanics, Prediction, and Assessment, Proceedings of the Second International Conference*: AA Balkema, Rotterdam, Netherlands, pp. 553–564.
- HINKLE, J., 2007, personal communication on 30 August, Oregon Department of Forestry, Salem, OR.
- HINKLE, J., 2008, personal communication on 7 February, Oregon Department of Forestry, Salem, OR.
- HOLLINGSWORTH, R. AND KOVACS, G. S., 1981, Soil slumps and debris flows: Prediction and protection: *Bulletin Association Engineering Geologists*, Vol. XVIII, No. 1, pp. 17–28.
- HUEBL, J. AND FIEBIGER, G., 2005, Debris-flow mitigation measures. In Jakob, M. and Hungr, O. (Editors), *Debris-Flow Hazards and Related Phenomena: Praxis*, Chichester, U.K., pp. 445–487.
- HUNGR, O. AND McCLUNG, D. M., 1987, An equation for calculating snow avalanche run-up against barriers. In Salm, B. and Gubler, H. (Editors), *Avalanche Formation, Movement and Effects* (Proceedings of the Davos Symposium, September 1986). IAHS Publication No. 162, Wallingford, Oxfordshire, UK, pp. 605–613.
- HUNGR, O.; McDUGALL, S.; AND BOVIS, M., 2005, Entrainment of material by debris flows. In Jakob, M. and Hungr, O. (Editors), *Debris-Flow Hazards and Related Phenomena: Praxis*, Chichester, U.K., pp. 135–158.
- HUNGR, O.; MORGAN, G. C.; AND KELLERHALS, R., 1984, Quantitative analysis of debris torrent hazards for design of remedial measures: *Canadian Geotechnical Journal*, Vol. 21, pp. 663–677.
- HUNGR, O.; MORGAN, G. C.; VANDINE, D. F.; AND LISTER, D. R., 1987, Debris flow defenses in British Columbia. In Costa, J. E. and Wieczorek, G. F. (Editors), *Reviews in Engineering Geology, Volume VII, Debris Flows/Avalanches: Process, Recognition, and Mitigation*: The Geological Society of America, Boulder, CO, pp. 201–222.
- KEYA, H., 1981, A method of designation for area in danger of debris flow. In Davies, T. R. H. and Pearce, A. J. (Editors), *Erosion and Sediment Transport in Pacific Rim Steeplands*: IAHS Publication No. 132, Christchurch, New Zealand, pp. 576–587.
- INMAN, D. L., 1952, Measures for describing the size distribution of sediments: *Journal Sedimentary Petrology*, Vol. 22, No. 3, pp. 125–145.
- IVERSON, R. M., 2005, personal communication on 17 October, U.S., Geological Survey, Vancouver, WA.
- JAKOB, M., 2005, A size classification for debris flows: *Engineering Geology*, Vol. 79, pp. 151–161.
- JAKOB, M. AND HUNGR, O., 2005, Introduction. In Jakob, M. and Hungr, O. (Editors), *Debris-Flow Hazards and Related Phenomena: Praxis*, Chichester, U.K., pp. 1–7.
- JOHNSON, A. M., 1984, Debris flow. In Brunsten, D. and Prior, D. B. (Editors), *Slope Instability*: ohn Wiley & Sons, Chichester, U.K., pp. 257–361.
- JOHNSON, P. A. AND MCCUEN, R. H., 1992, Effect of debris flows on debris basin design: *Critical Reviews in Environmental Control*, Vol. 22, pp. 137–149.
- L. A. COUNTY, 2005, *Debris Dams and Basins Outlet Works, Standard Plan 3097-0*: Los Angeles County Department of Public Works, Electronic document, available at [http://ladpw.org/des/Design\\_Manuals/](http://ladpw.org/des/Design_Manuals/)
- LIN, P.-S.; CHANG, W.-J.; AND LIU, K.-S., 1997, Retaining function of open-type sabo dams. In Chen, C.-l. (Editors), *Debris-Flow Hazards Mitigation: Mechanics, Prediction, and Assessment, Proceedings of the First International Conference*: ASCE, New York, pp. 636–645.
- LO, D. O. K., 2000, *Review of Natural Terrain Landslide Debris-Resisting Barrier Design*: GEO Report No. 104, Geotechnical Engineering Office, Civil Engineering Department, The Government of Hong Kong Special Administrative Region, Electronic document, available at [http://www.cedd.gov.hk/eng/publications/geo\\_reports/index.htm](http://www.cedd.gov.hk/eng/publications/geo_reports/index.htm)
- MARTIN, D. C.; PITEAU, D. R.; PEARCE, R. A.; AND HAWLEY, P. M., 1984, Remedial measures for debris flows at the Agassiz Mountain Institution, British Columbia: *Canadian Geotechnical Journal*, Vol. 21, pp. 505–517.
- McDONALD, G. N. AND GIRAUD, R. E., 2002, *September 12, 2002, Fire-Related Debris Flows East of Santaquin and Spring Lake, Utah County, Utah*: Utah Geological Survey Technical Report 02-09, Electronic document, available at <http://geology.utah.gov/online/techrpt/santaquin0902.pdf>
- MEARS, A. I., 1981, *Design Criteria for Avalanche Control Structures in the Runout Zone*: General Technical Report RM-84, Rocky Mountain Forest and Range Experiment Station, USDA Forest Service, Fort Collins, CO.
- MIYAZAWA, N.; TANISHIMA, T.; SUNADA, K.; AND OISHI, S., 2003, Debris-flow capturing effect of grid type steel-made sabo dam using 3D distinct element method. In Rickenmann, D. and Chen, C.-l. (Editors), *Debris-Flow Hazards Mitigation: Mechanics, Prediction, and Assessment, Proceedings of the Third International Conference*: Millpress, Rotterdam, Netherlands, pp. 527–538.
- NASMITH, H. W. AND MERCER, A. G., 1979, Design of dykes to protect against debris flows at Port Alice, British Columbia: *Canadian Geotechnical Journal*, Vol. 16, pp. 748–757.
- NASSERI, I.; KLIPPEL, S.; WILLARDSON, B.; SORIANO, L.; MOYER, J.; AND GAPLANDZHAYAN, M., 2006, *Sedimentation Manual*, 2nd ed.: Los Angeles County Department of Public Works—Water Resources Division, Electronic document, available at <http://ladpw.org/wrd/Publication/index.cfm>
- PIERSON, T. C., 1985, Initiation and flow behavior of the 1980 Pine Creek and Muddy River lahars, Mount St. Helens, Washington: *Geological Society America Bulletin*, Vol. 96, pp. 1056–1069.
- PROCHASKA, A. B.; SANTI, P. M.; HIGGINS, J. D.; AND CANNON, S. H., 2008a, Debris-flow runout predictions based on the average channel slope (ACS): *Engineering Geology*, Vol. 98, pp. 29–40, doi: 10.1016/j.enggeo.2008.01.011.
- PROCHASKA, A. B.; SANTI, P. M.; HIGGINS, J. D.; AND CANNON, S. H., 2008b, A study of methods to estimate debris-flow velocity: *Landslides*: in press.
- RICKENMANN, D., 2005, Runout prediction methods. In Jakob, M. and Hungr, O. (Editors), *Debris-Flow Hazards and Related Phenomena: Praxis*, Chichester, U.K., pp. 305–324.
- ROGERS, S., 2007, personal communication on 17 September, Natural Resources Conservation Service, Provo, UT.

## Debris-Flow Mitigation Design

- ROGERS, S., 2008, personal communication on 22 February, Natural Resources Conservation Service, Provo, UT.
- SCHWARTZ, G. E. AND ALEXANDER, R. B., 1995, *State Soil Geographic (STATSGO) Database for the Conterminous United States*: U.S. Geological Survey Open-File Report 95-449, Electronic document, available at <http://water.usgs.gov/GIS/metadata/usgswrd/XML/ussoils.xml>
- SCOTTON, P. AND DEGANUTTI, A. M., 1997, Phreatic line and dynamic impact in laboratory debris flow experiments. In Chen, C.-I. (Editor), *Debris-Flow Hazards Mitigation: Mechanics, Prediction, and Assessment, Proceedings of the First International Conference*: ASCE, New York, pp. 777-786.
- SHERARD, J. L.; WOODWARD, R. J.; GIZIENSKI, S. F.; AND CLEVINGER, W. A., 1963, *Earth and Earth-Rock Dams*: John Wiley and Sons, New York, 725 p.
- STATE OF COLORADO, 2007, *Rules and Regulations for Dam Safety and Dam Construction*: Department of Natural Resources, Division of Water Resources, Office of the State Engineer, Denver, CO.
- SUN, H. W. AND LAM, T. T. M., 2004, *Use of Standardised Debris-Resisting Barriers for Mitigation of Natural Terrain Landslide Hazards*: Landslip Preventive Measures Division 1 Special Project Report SPR 9/2004, Hong Kong.
- VANDINE, D. F., 1985, Debris flows and debris torrents in the Southern Canadian Cordillera: *Canadian Geotechnical Journal*, Vol. 22, pp. 44-68.
- VANDINE, D. F., 1996, *Debris Flow Control Structures for Forest Engineering*: Ministry of Forests Research Program Working Paper 08/1996, Victoria, British Columbia.
- VANDINE, D. F.; HUNGR, O.; LISTER, D. R.; AND CHATWIN, S. C., 1997, Channelized debris flow mitigative structures in British Columbia, Canada. In Chen, C.-I. (Editor), *Debris-Flow Hazards Mitigation: Mechanics, Prediction, and Assessment, Proceedings of the First International Conference*: ASCE, New York, pp. 606-615.
- WILLARDSON, B., 2008, personal communication on 11 February, Los Angeles County Department of Public Works-Water Resources Division, Alhambra, CA.
- WILLARDSON, B. AND WALDEN, A., 2003, *Development of Burn Policy Methodology (Santa Clara River Watershed Pilot Program)*: Los Angeles County Department of Public Works-Water Resources Division, Alhambra, CA.



## APPENDIX K – EXISTING PIPE SYSTEM ANALYSIS

### Storm Drain Pipe Analysis

Pipes highlighted red had an estimated flow rate that is larger than the full flow pipe capacity. Storm drain profiles of these pipes show that they become pressurized but that they still have enough capacity to handle the estimated flow rates. The 350 W profile confirms that this system does not have adequate capacity.

#### 1030 East & Oak Summit

Flow (cfs)	Pipe Capacity (cfs)
5.19	9.25
8.57	26.49
11.54	27.6
14.32	44
1.09	19.7
1.08	19.58
1.06	18.63

#### Apple View Area

Flow (cfs)	Pipe Capacity (cfs)
9.89	38.63
24.09	36.02
32.27	29.96
36.72	57.1

N Center  
 Ginger Gold  
 Royal Land  
 860 N

Pipe ID	Flow (cfs)	Pipe Capacity (cfs)
860 N CO-17	0	4.78
860 N CO-18	5.77	6.69
860 N CO-19	5.47	12.74
N Center CO-20	18.79	76.42
N Center CO-21	29.86	61.8
N Center CO-22	30.7	42.55
N Center CO-23	31.83	90.38
Ginger Gold CO-24	36.81	14.88
Ginger Gold CO-25	35.75	105.4
Ginger Gold CO-27	6.04	19.59
Ginger Gold CO-28	5.87	34.77
Royal Land CO-29	6.38	6.41
Royal Land CO-30	6.2	9.17
Royal Land CO-33	11.1	9.43
Royal Land CO-35	10.98	12.19
Royal Land CO-36	10.8	7.32

350 West

	Flow (cfs)	Pipe Capacity (cfs)
350 W CO-37	8.65	8.87
350 W CO-38	10.02	0
350 W CO-13	6.02	3.9
350 W CO-14	7.77	5.17
350 W CO-16	10.92	6.06

Snapshot of modeled areas:



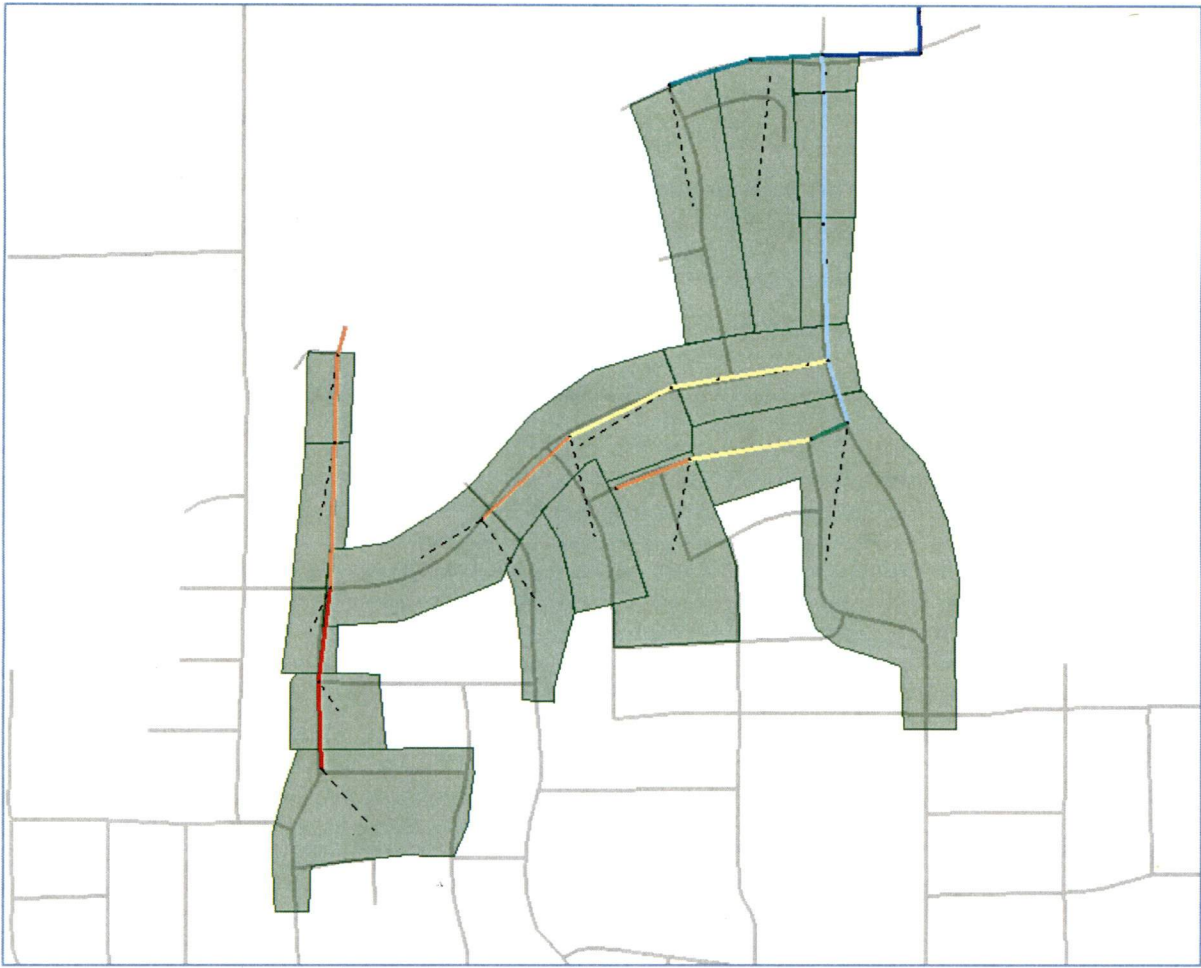

Trunk line profiles:

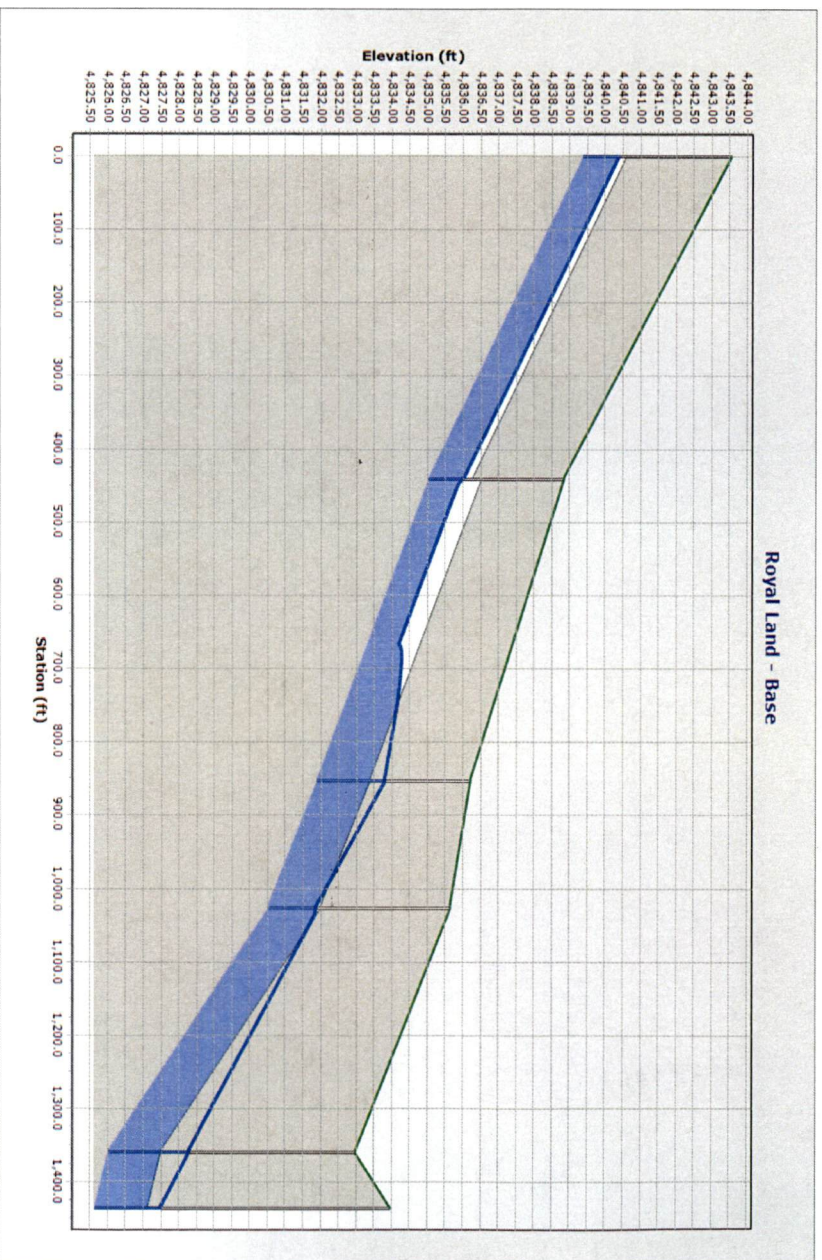

### Ginger Gold - Base

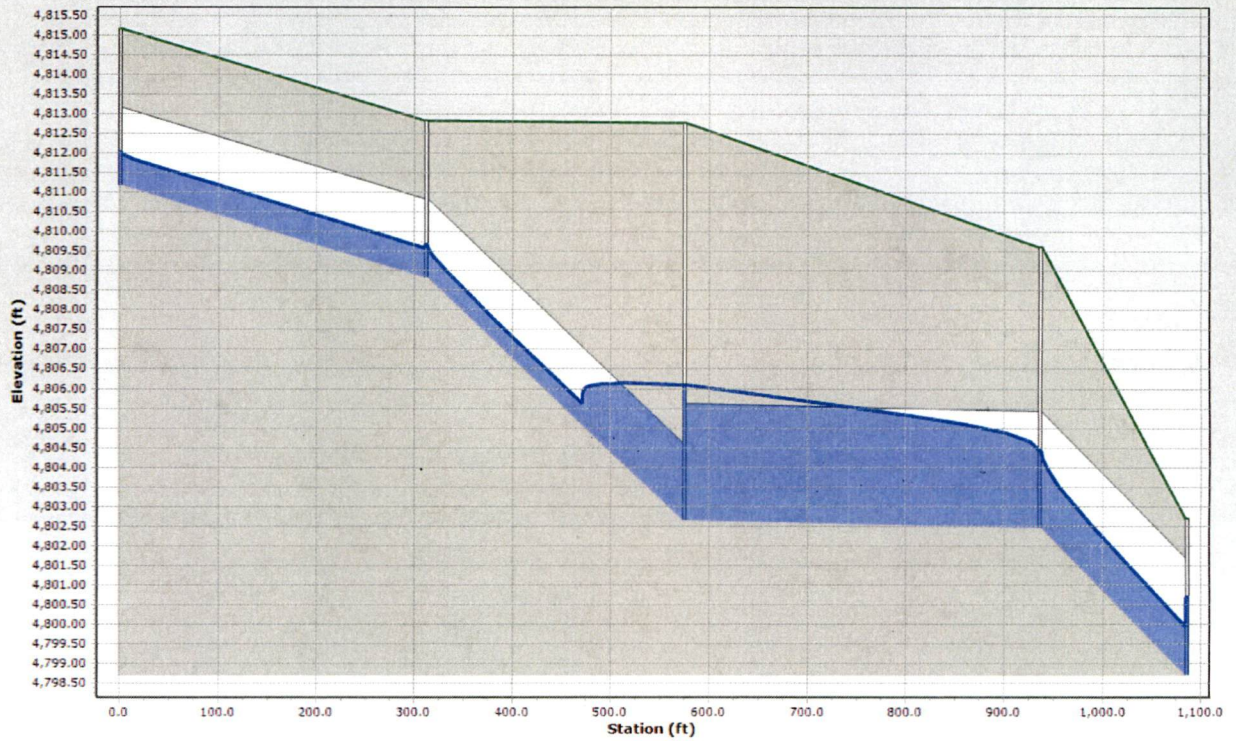

860 N & Cntr - Base

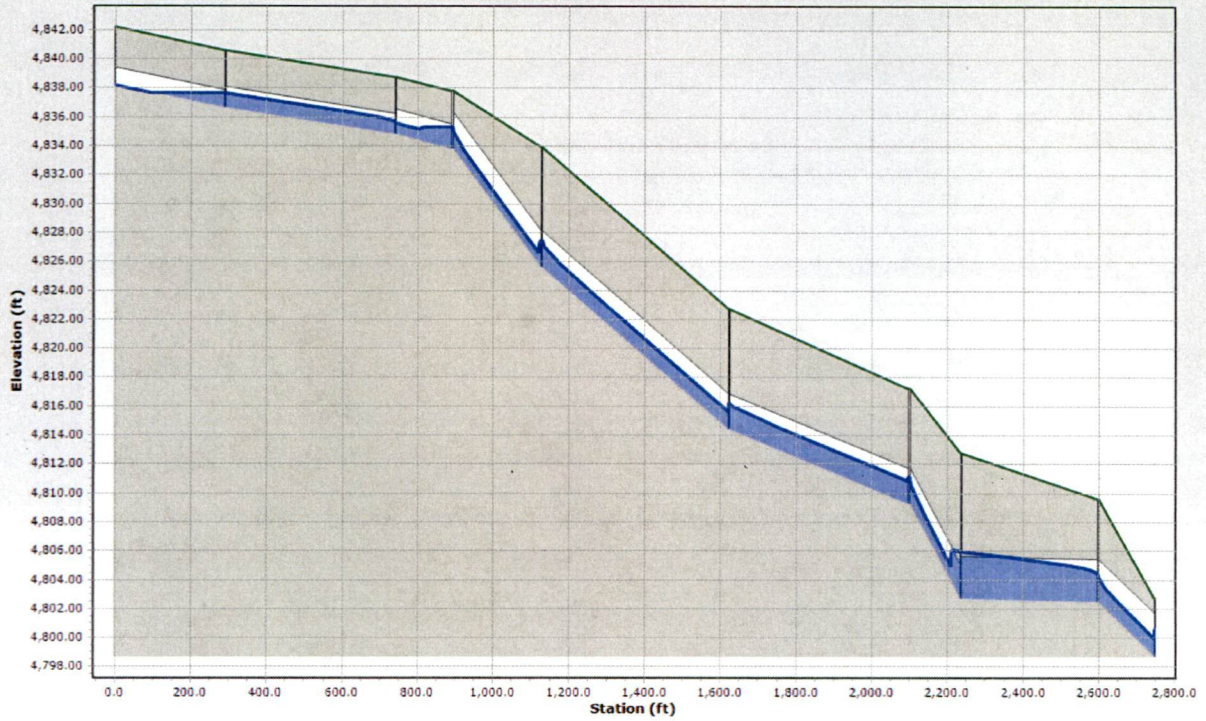

350 W - Base

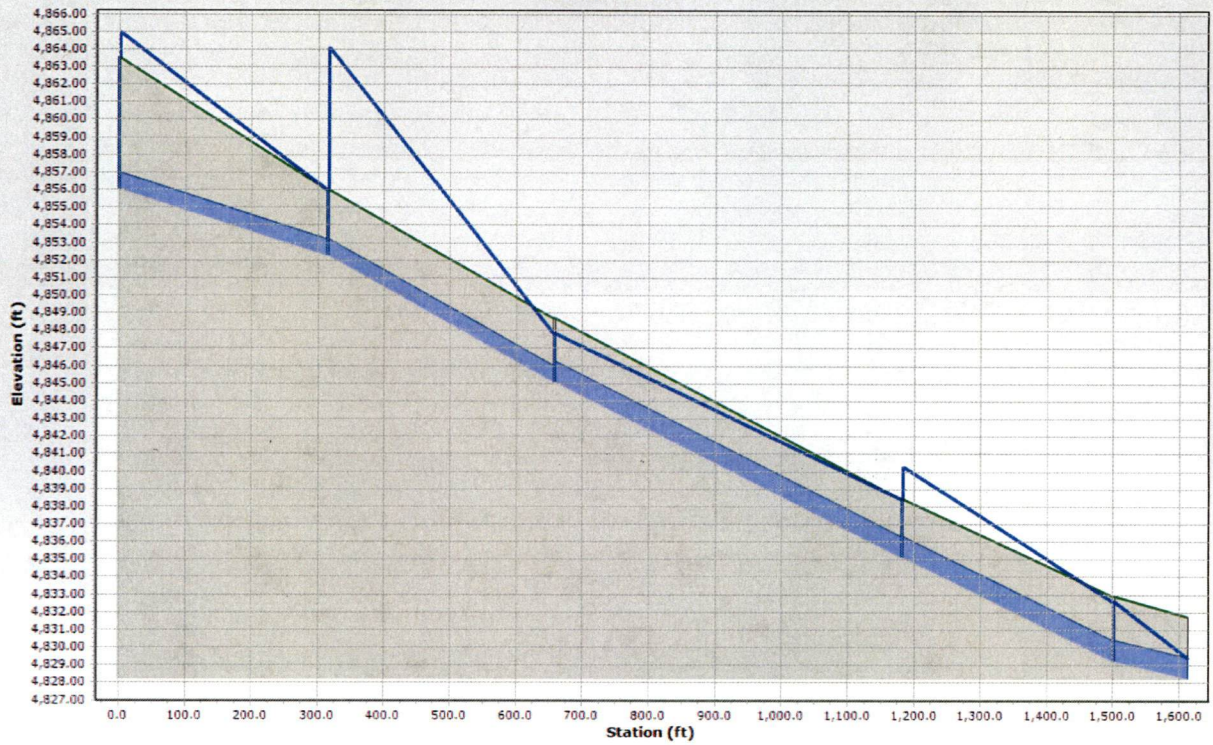



## APPENDIX L – LAND USE AND ZONING MAPS

- Master Plan Future Zoning Map
- Existing Land Use Map

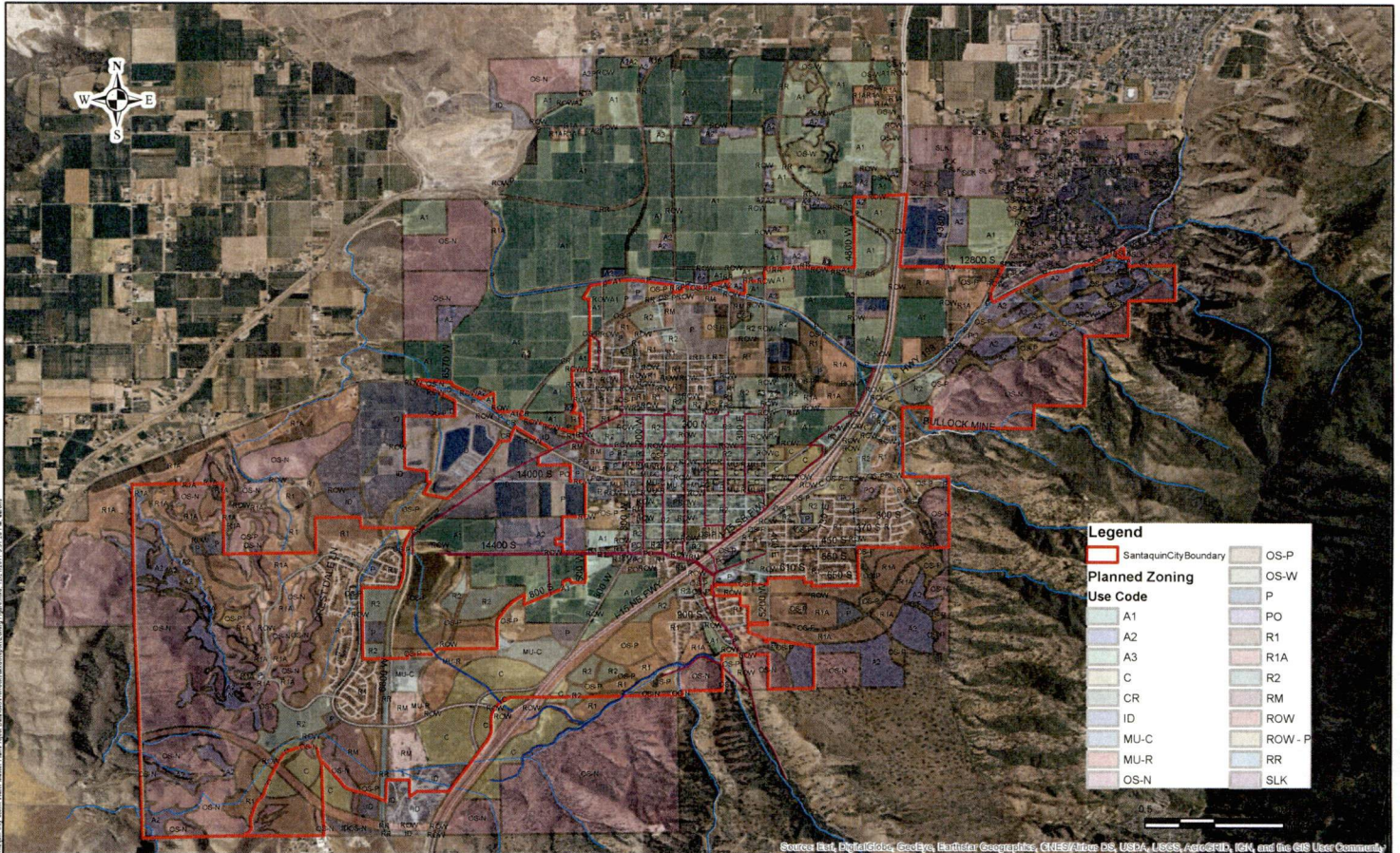

Sources: Esri, DigitalGlobe, GeoEye, Earthstar Geographics, CNES/Airbus DS, USDA, USGS, AeroGRID, IGN, and the GIS User Community



Zoning Plan  
Buildout Scenario

12/21/2017

Figure ??

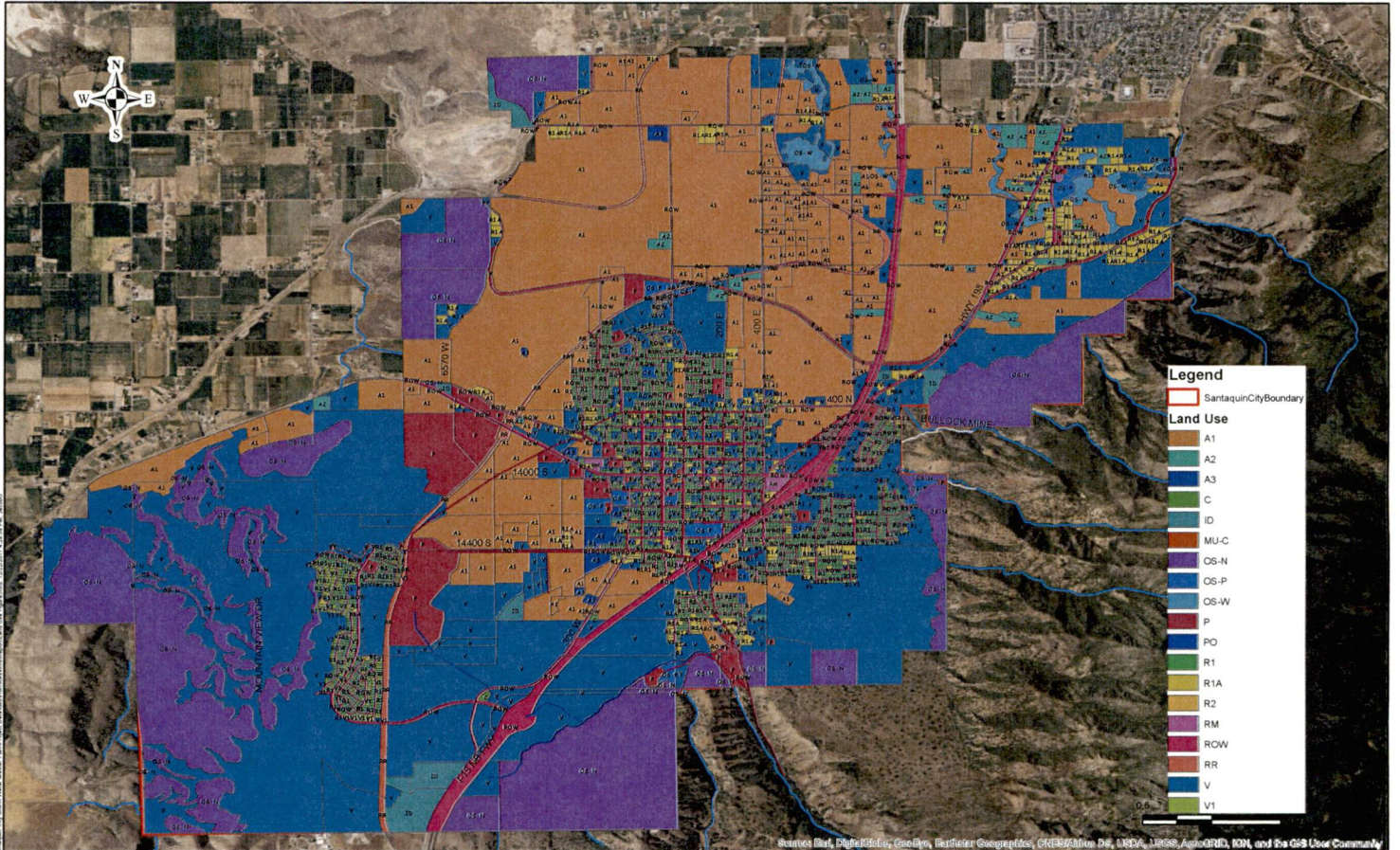

Land Use Map

Buildout Scenario

12/22/2017

Figure ??